

CE

**bycool!**  
green line

**COMPACT 3.0**

**M.B. ACTROS**

**< 2011**



**Instrucciones de Montaje**

*Mounting Instructions*

**Instructions de Montage**

*Montageanweisungen*

**Istruzioni di Montaggio**

**ES** Spanish

**EN** English

**FR** French

**GE** German

**IT** Italian

## Recomendaciones Para el montaje

- Antes de iniciar el montaje leer las instrucciones y seguirlas durante el proceso de instalación.
- Usar las herramientas adecuadas para cada operación.

## Electricidad

- Desconectar la llave de contacto.
- Desconectar la batería antes de empezar el montaje.
- Asegurar el conexionado de los componentes eléctricos, verificando su correcto encaje.

### Atención

Si durante el montaje el equipo se inclina, se deberá esperar un mínimo de 60 minutos desde que el equipo quede en posición horizontal antes de ponerlo en funcionamiento.

### Atención

Al instalar el equipo de aire acondicionado en el techo se debe proteger la parte superior de la cabina con un paño ó manta protectora para evitar posibles arañazos. Al instalar **Compact** en el techo hay que tener en cuenta que, normalmente, las cabinas que vienen provistas de escotilla, tienen una estructura suficiente para soportar el peso del equipo. Sin embargo, cuando no ocurra así y sea necesario realizar corte en el techo ó incluso si en el caso de llevar escotilla el material no es lo suficientemente resistente (caso de techo de fibra, plástico, etc...) es el instalador el que debe decidir, **bajo su responsabilidad**, sobre la necesidad de reforzar el techo para evitar posibles deformaciones, roturas, entradas de agua, etc... habilitando los medios para que esto no ocurra.

## Herramientas

- Juego de Llaves Torx
- Juego de Llaves Allen
- Llave fija 10, 13, 14
- Tijeras
- Flexómetro







## Documentación incluida

Instrucciones de montaje	220.AA2.7002
Manual del usuario	220.AA6.0057
Diagnos de averías	220.AA6.0058
Garantía	220.AA1.0017

## Simbología

-  Frágil
-  Atención corte!
-  Riesgo eléctrico

## Advertencias

-  El personal instalador debe poseer una formación suficiente en Aire Acondicionado de vehículos.
-  **dirnaBergstrom, s.l.** queda exenta de responsabilidad si se producen averías que procedan de una inadecuada manipulación ó instalación del equipo, ó por modificaciones y sustituciones efectuadas sin nuestra expresa autorización por escrito.
-  **Equipo precargado con gas refrigerante. (No manipular el circuito de gas refrigerante).**
-  Véase **procedimiento de garantía** del producto incluido en **Diagnos de Averías**.
-  Véase **Manual de Usuario** del equipo para el correcto funcionamiento del mando a distancia y del panel de control.
-  Al finalizar la instalación se debe entregar al usuario: **Manual del Usuario, Garantía y Diagnos de averías.**

 Antes de empezar con el montaje, montar rejilla entrada aire delantera.



**1** Desmontar tapa escotilla, los elementos de fijación y reservar.  
 (\*) marco interior.



**2** Quitar los residuos sobrantes adheridas al techo antes de pegar la junta EPDM.

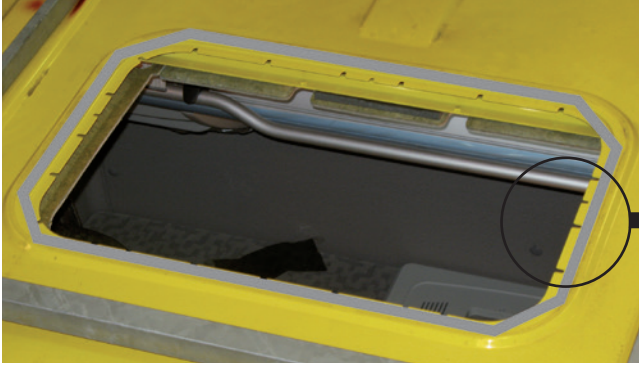

**3** Pegue la junta EPDM alrededor del hueco de escotilla (*mirar el detalle para cortar los bordes finales de unión de la junta*).

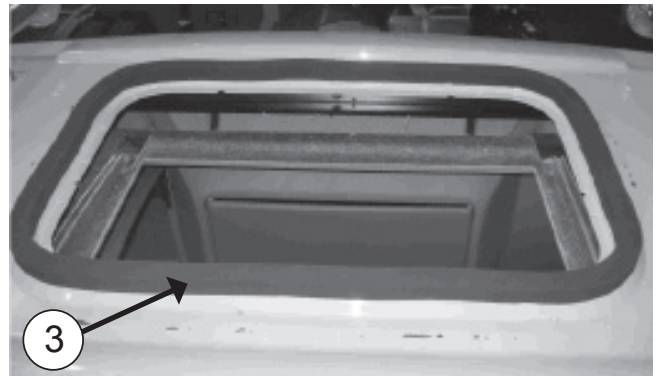

**COMO CORTAR LA JUNTA EPDM PARA EVITAR FILTRACIÓN DE AGUA EN LA CABINA**

- A- Pegar la junta, manteniendo 100 mm de papel protector por cada lado.
- B- Quitar los dos piezas de papel.
- C- Pegue presionado ambos finales.

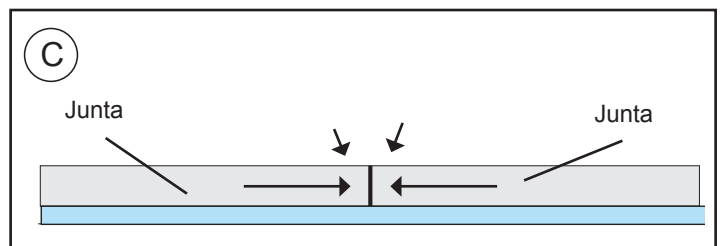
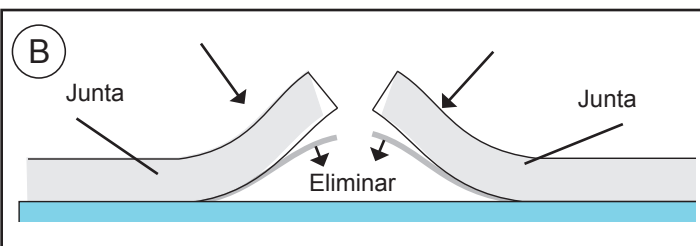
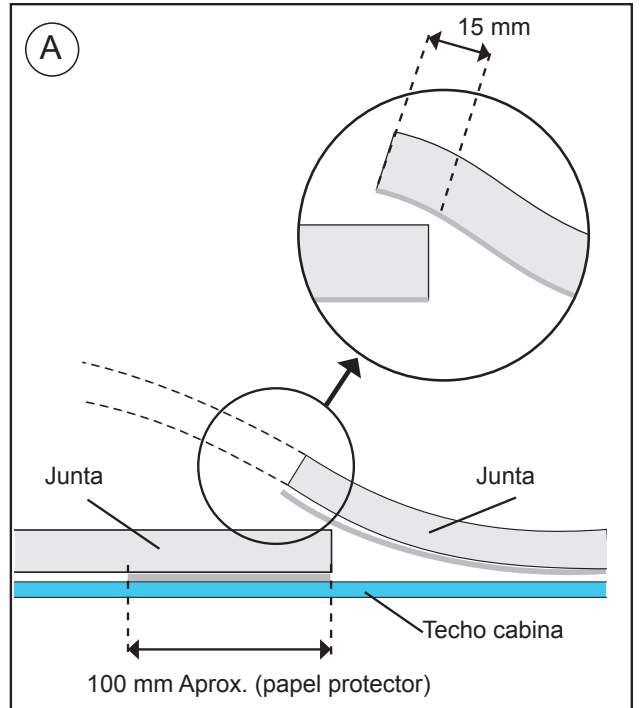



**4** **EXTERIOR CABINA:**  
 Posicionar el Compact en el hueco de la escotilla.  
**¡Atención! Al colocar el equipo encima del hueco escotilla, revisar que las salidas de desagüe no queden obstruidas por la junta EPDM.**

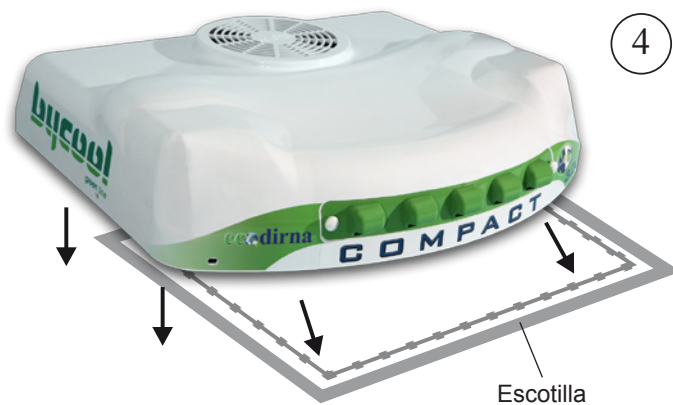

**5** Colocar canalizador gomaespuma quedando la parte más blanda en la base del equipo.



**6** **INTERIOR CABINA:**  
 Roscar 5 mm aproximadamente (4) espárragos 8/125x100-70 ó 120, la medida se elegirá tras presentar los soportes de sujeción y teniendo en cuenta que los espárragos deben sobresalir de los mismos por la parte inferior unos 20 mm.

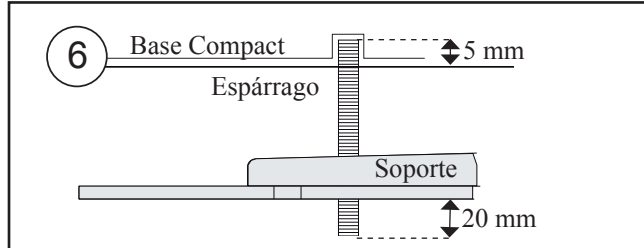

**7** Colocar (1) arandela Ø 7 de goma, (1) arandela plana Ø 8 ala ancha, (2) tuerca M8 y (1) arandela plana Ø 8 ala ancha, en cada uno de los espárragos anteriores; siguiendo dicho orden.

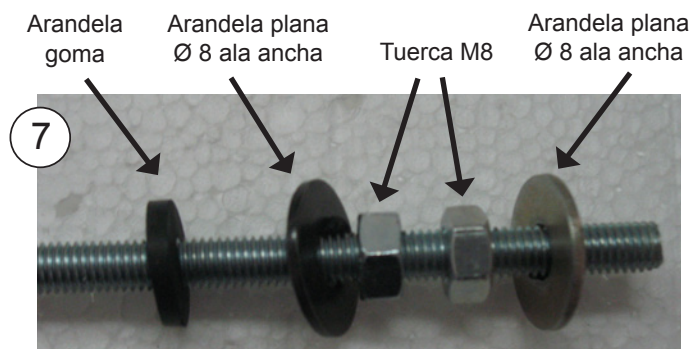

**8** Colocar (2) soportes sujeción, con (1) arandela y (1) tuerca autoblocante M8, **sin llegar a apretar.**

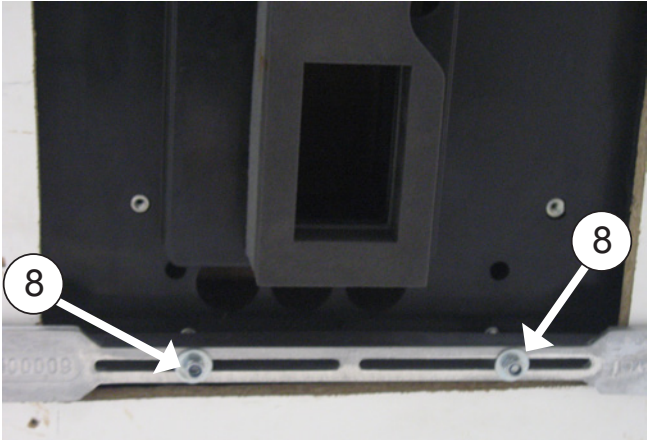
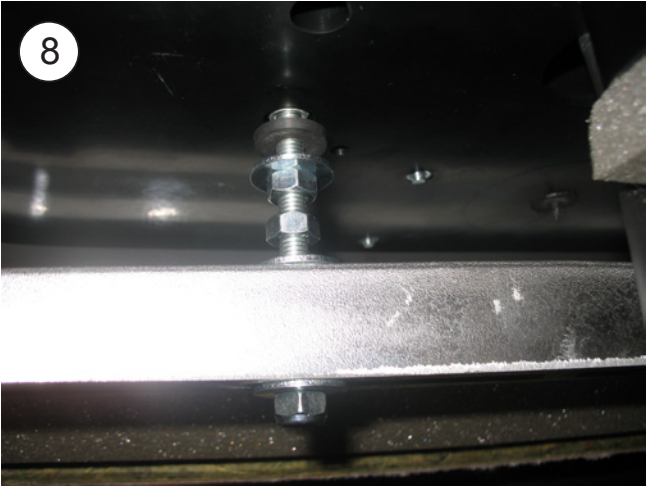

**9** Roscar 10 mm (4) espárragos M6 x 55 ó 80, donde se indica, según distancia (D) del esquema del punto 11.

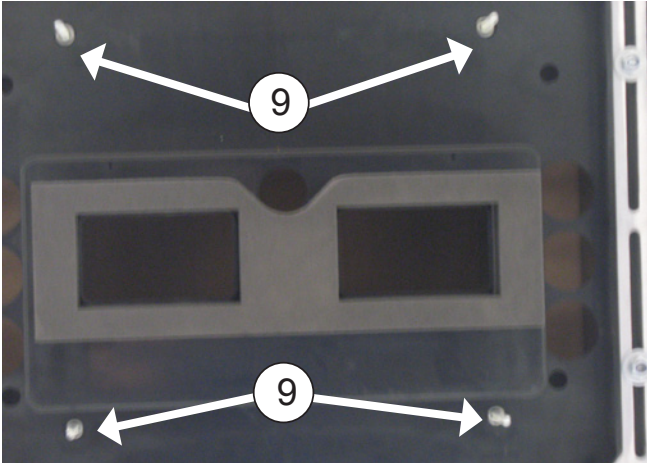

**10** Colocar (1) arandela Ø6 de goma, (1) arandela plana Ø6 ala ancha y (1) tuerca M6, sobre cada uno de los espárragos de M6. **Apretar tuerca**, a continuación apretar tuerca hasta que la arandela de goma quede un poco oprimida.

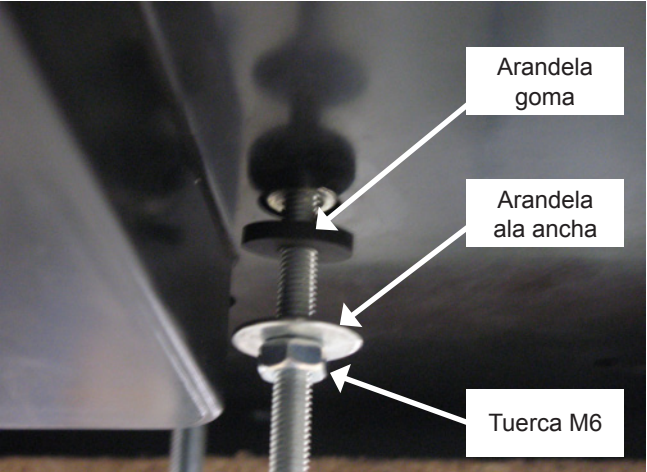



10a

Colocar (1) tuerca M6 sin apretar en cada espárrago.

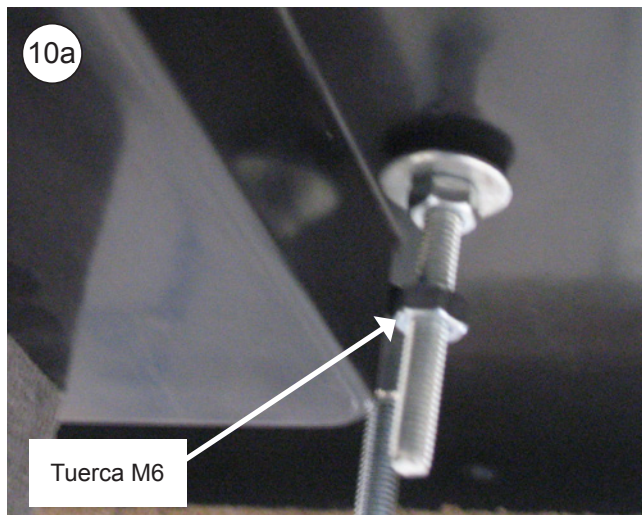

Tuerca M6

10b

Conectar (2) cables de comunicación (A), las (2) cajas de 4 vías y (4) de 2 vías; del panel interior de distribución de aire con las del Compact.

Tener en cuenta que la caja de 2 vías marcada con cables blancos se une al conector con cables blancos que sale por la parte central del equipo.

**Atención: Es muy importante no invertir los colores de los cables de la caja 2 vías del ventilador del condensador (caja con cables R y N).**

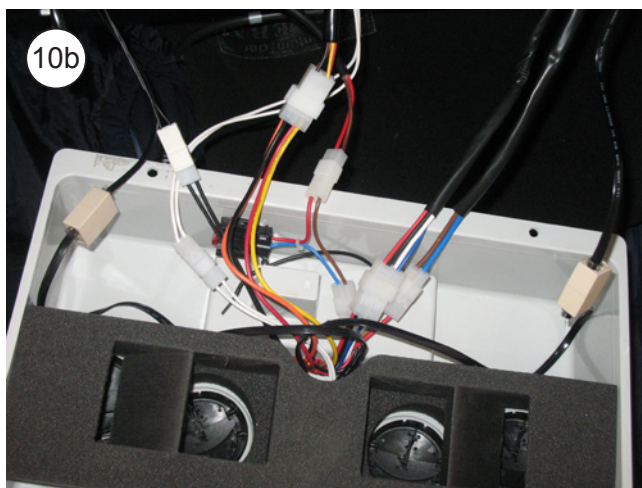

10c

Introducir cableados en el hueco existente (H) en el panel interior de distribución de aire para no interferir en el ajuste de los canalizadores con la base del equipo.

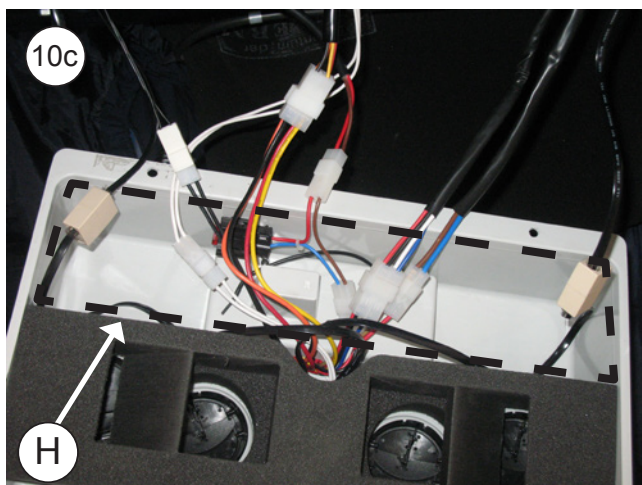

**11** Colocar panel interior de distribución de aire en los espárragos anteriores con (1) arandela M6 ala ancha y (1) tuerca M6 en cada espárrago. Apretar tuercas hasta que el canalizador de gomaespuma haga tope en goma espuma superior del equipo.

**Importante:** El canalizador de gomaespuma debe hacer tope contra la goma espuma superior del equipo para evitar fugas de aire.

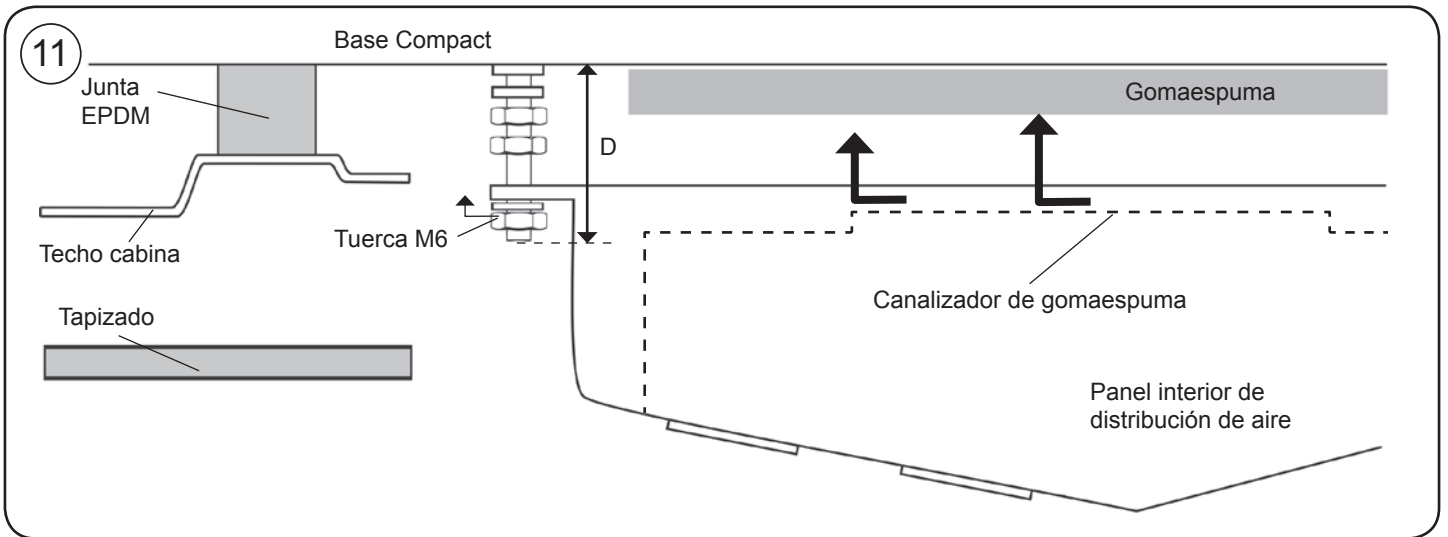

**12** Apretar tuerca del punto 10a hasta hacer tope con la parte superior del panel interior de distribución de aire.

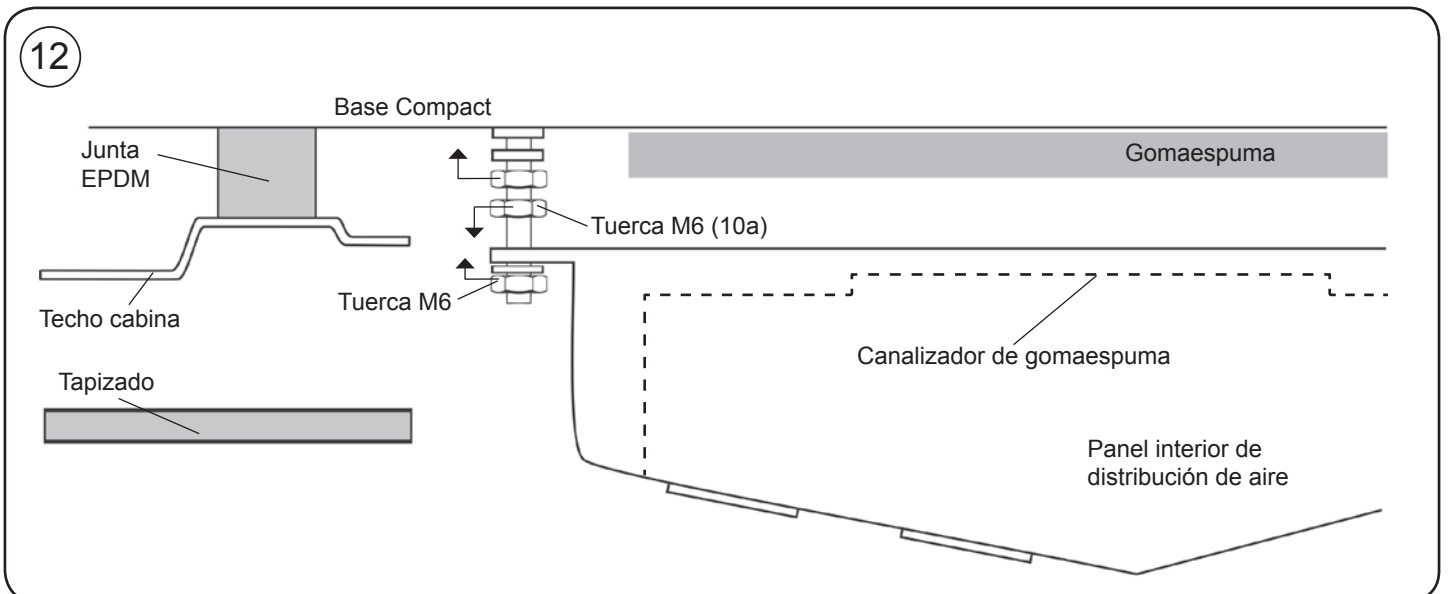



**13** Separar en dos la consola original, desmontado los tornillos de unión entre ambas, situados en la parte posterior.



**14** Montar marco de consola **A** con tornillos originales en su posición original.

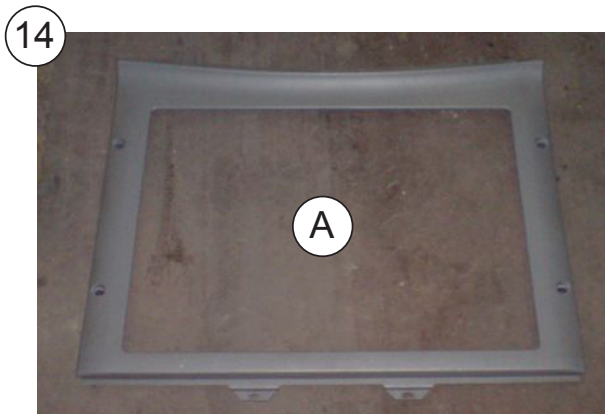

**15** Presentar consola suministrada sobre marco consola original y centrar equipo.

**ATENCIÓN DEBE TAPAR EL HUECO EXISTENTE ENTRE MARCO CONSOLA Y EL FRENTE.**



**16** Fijar los soportes de sujeción apretando las tuercas hasta el apriete de la junta de EPDM exterior del equipo entre 3 y 6 mm.

**Importante:** Para evitar posibles filtraciones de agua al interior de la cabina se debe asegurar el apriete de la junta EPDM con la base del **Compact** tal y como se indica en el **esquema**.

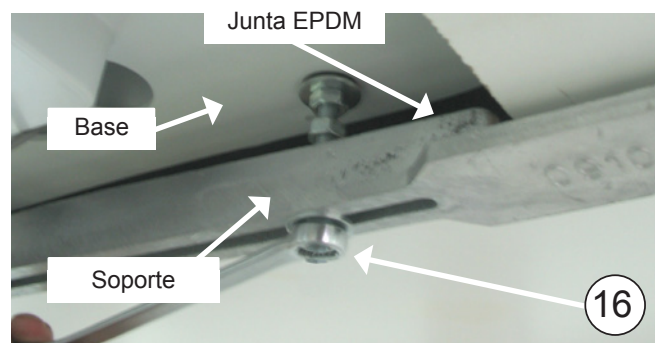
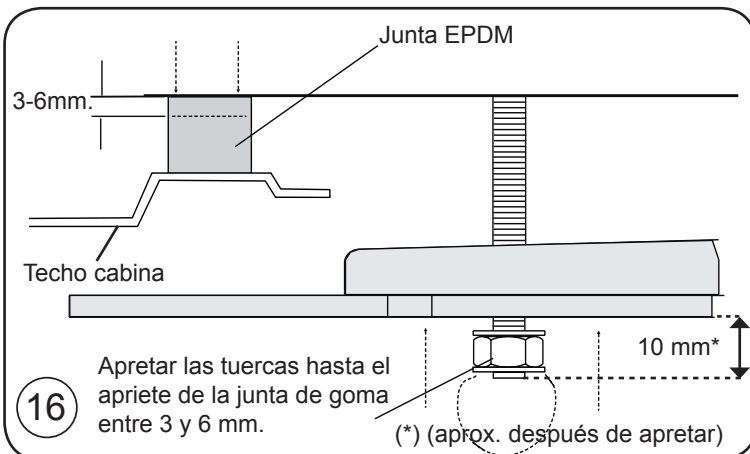

**17** Apretar (4) tuercas M8 al soporte y (4) a la base del Compact.

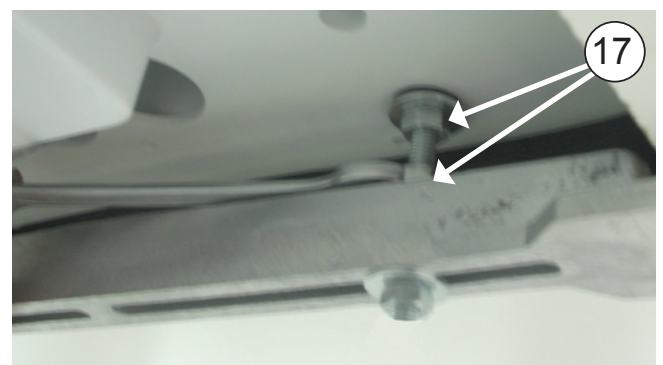

**18**

Fijar consola sobre marco de consola original con (8) tornillos roscachapa 3,5x16, habiendo efectuado con anterioridad (8) taladros Ø 3.

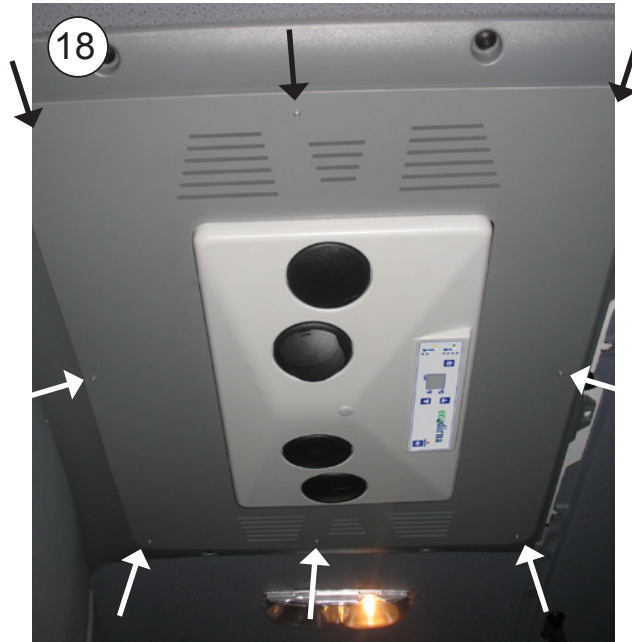

### Vista explosionada hasta la fijación de los soportes

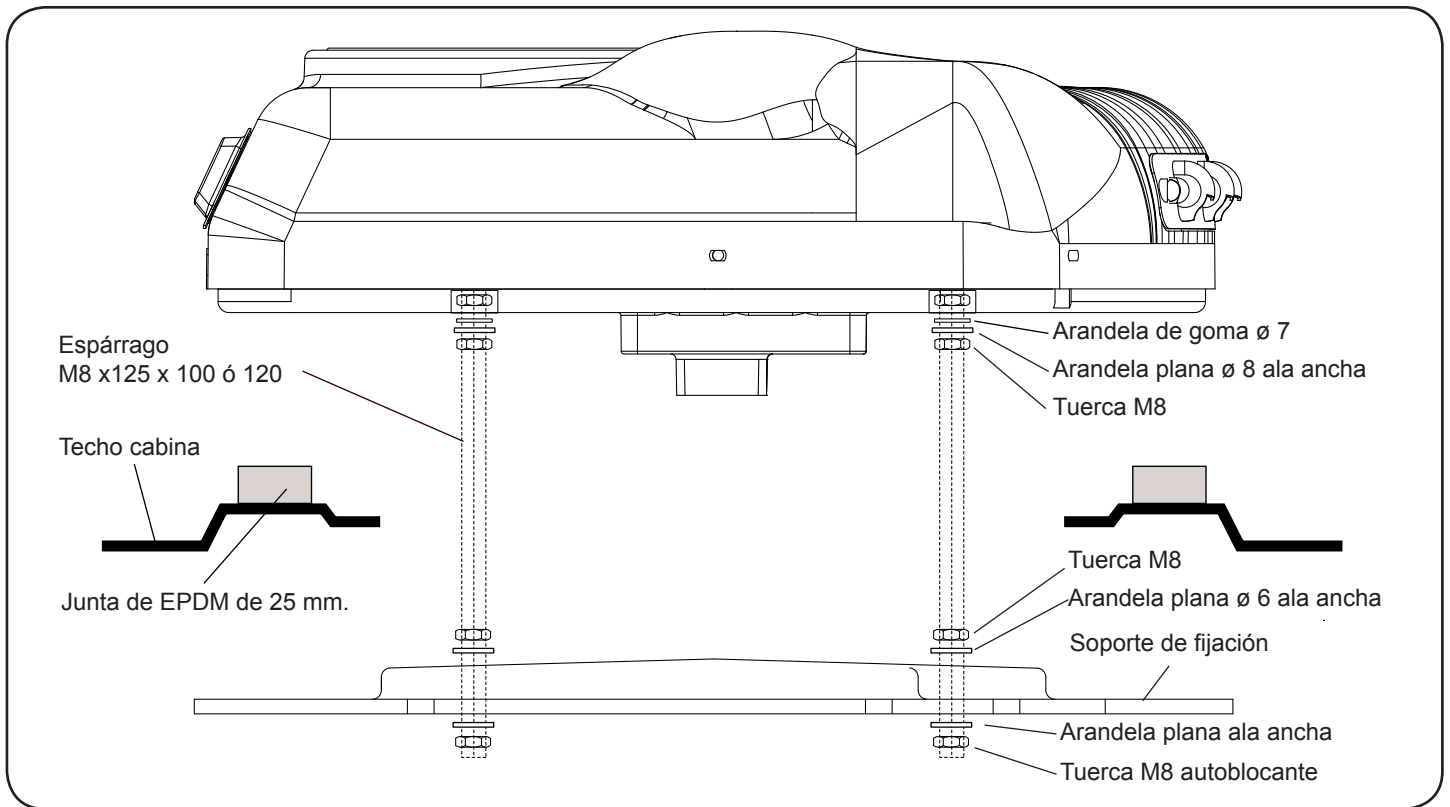

### Vista explosionada hasta la fijación de las consolas

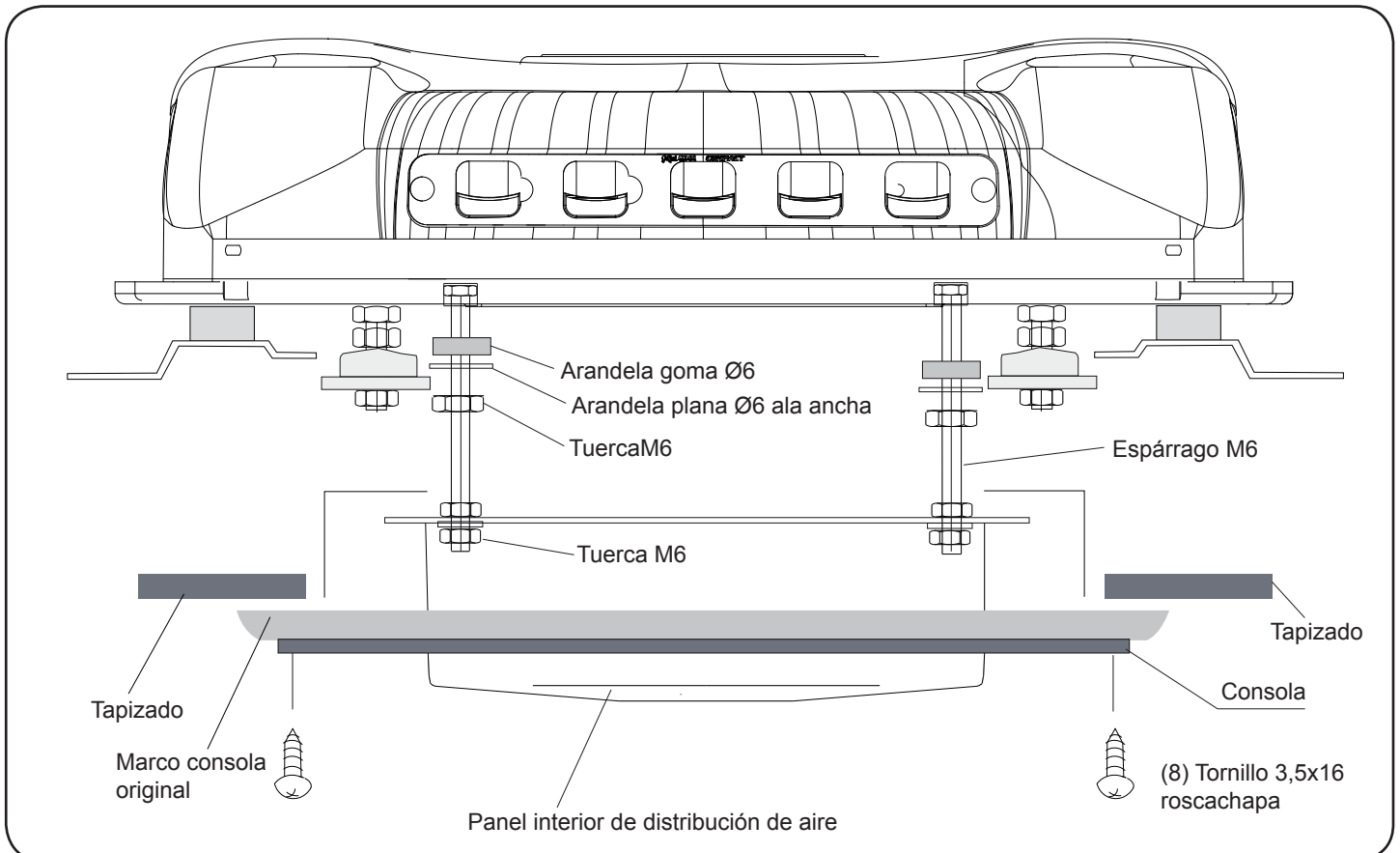



## Instrucciones detalladas sobre la instalación del cableado de alimentación

1

Conectar el cable de alimentación superior en la parte trasera del equipo y llevarlo por la parte posterior de la cabina pegando los soportes de plástico y fijándolo con bridas.



2

Conectar cableado de alimentación inferior a clema de cableado de alimentación superior.



### Conexión a baterías traseras

**3** Llevar cable positivo (azul) a caja de conexiones en la posición X3. Cortar cable sobrante, grapar terminal Ø 6 suministrado y conectarlo junto con el tramo del fusible. Fijar cable en posición X3 con arandela y tuerca autoblocante.

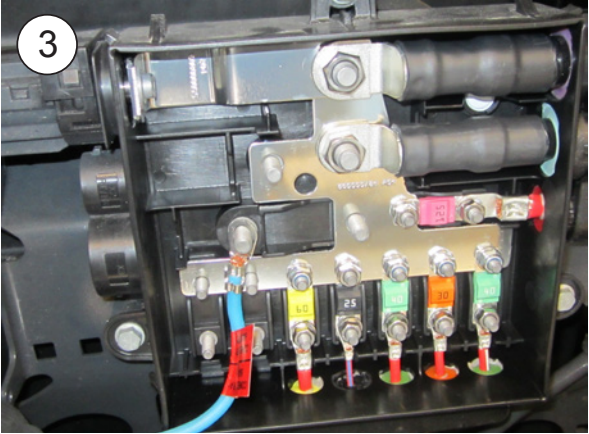
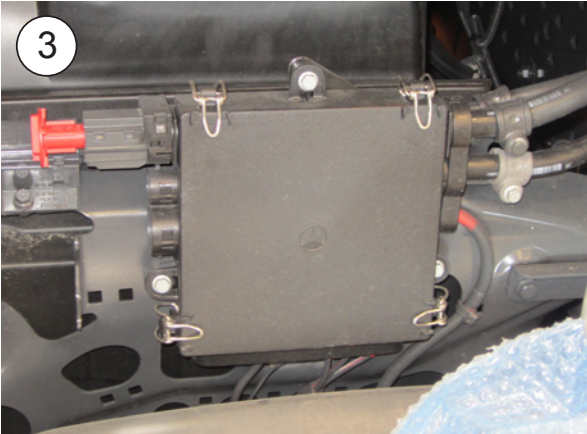
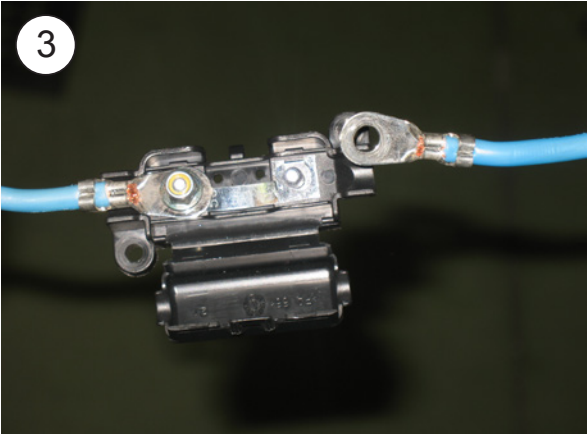
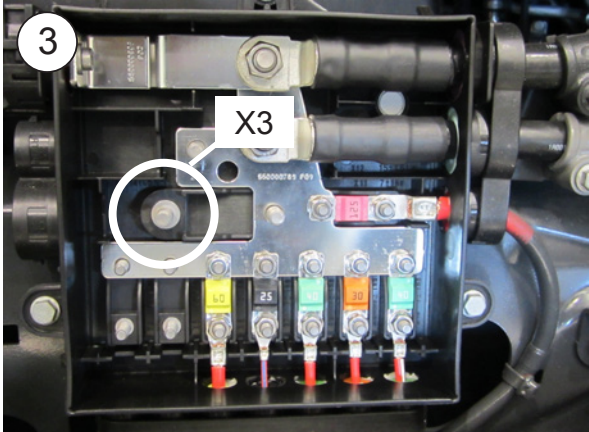

**4** Llevar cable negativo (marrón) a caja conexión negativa situada cerca de las baterías. Fijar cable con arandela y tuerca autoblocante.

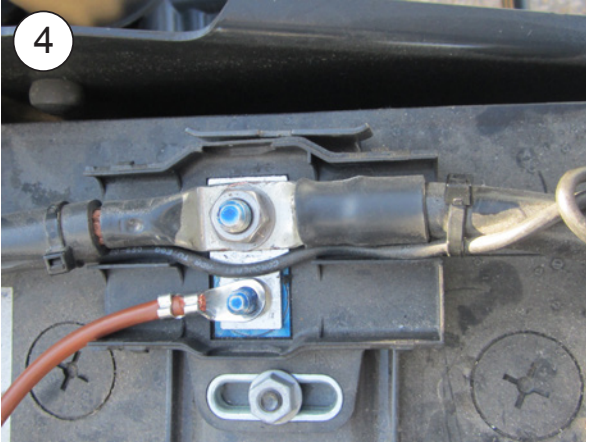



### Baterías delanteras

**3** Llevar cable positivo (azul) a caja de conexiones (situada cerca de las baterías) en la posición X3. Cortar cable sobrante, grapar terminal Ø 6 suministrado y conectarlo junto con el tramo del fusible suministrado y conectarlo junto con el tramo del fusible. Fijar cable en posición X3 con arandela y tuerca autoblocante.

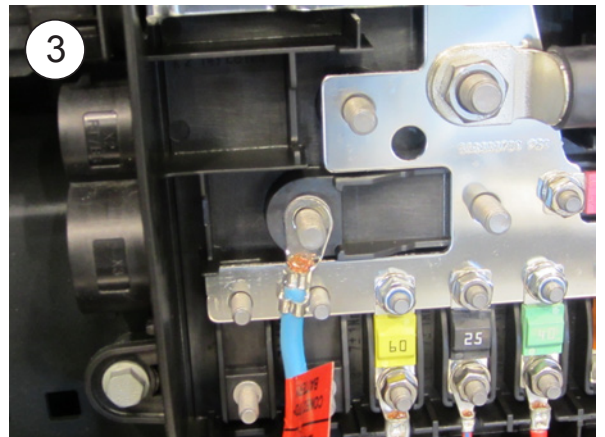
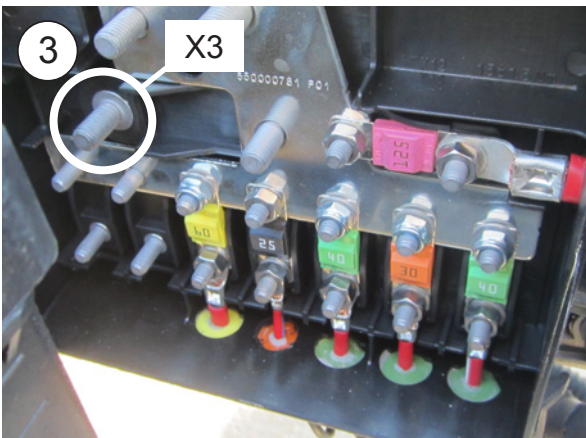
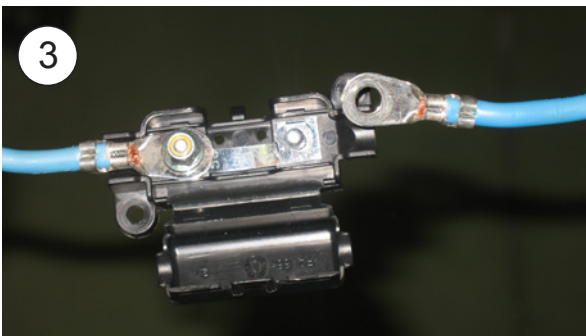

**4** Llevar cable negativo (marrón) a caja conexión negativa situada junto a borne negativo de la batería. Cortar cable sobrante y grapar terminal Ø 10 y fijar con arandela y tuerca autoblocante.

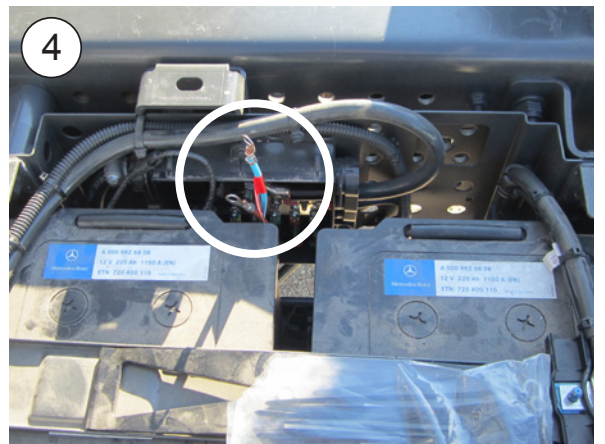

## Conexión directa a baterías

**3** Llevar cableados positivo y negativo a batería pasándolos por paso original de cableados y fijándolo con bridas.

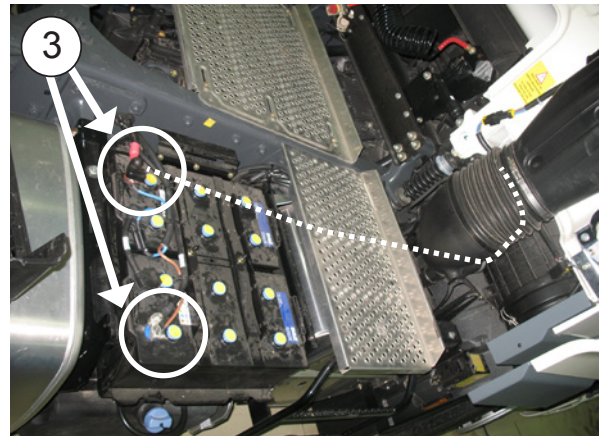

**4** Cortar cables sobrante, grapar terminales suministrados y conectar.

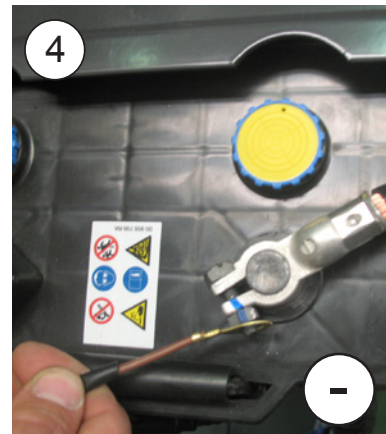

**⚠** **ATENCIÓN:** ¡Al conectar los cableados dejar la distancia adecuada para entrar su rotura por los movimientos de la cabina!

**IMPORTANTE:** Para la puesta en marcha consultar el manual de usuario.

**5** Colocar adhesivos de peligro en unión de cableado y en dispositivo de elevación de cabina.





¡AVISO IMPORTANTE!

**Precaución** de no invertir las polaridades al conectar la alimentación en el equipo. Si esto sucediera la placa no se encenderá, el equipo no funcionará y se producirán daños irreparables en los módulos de los compresores.

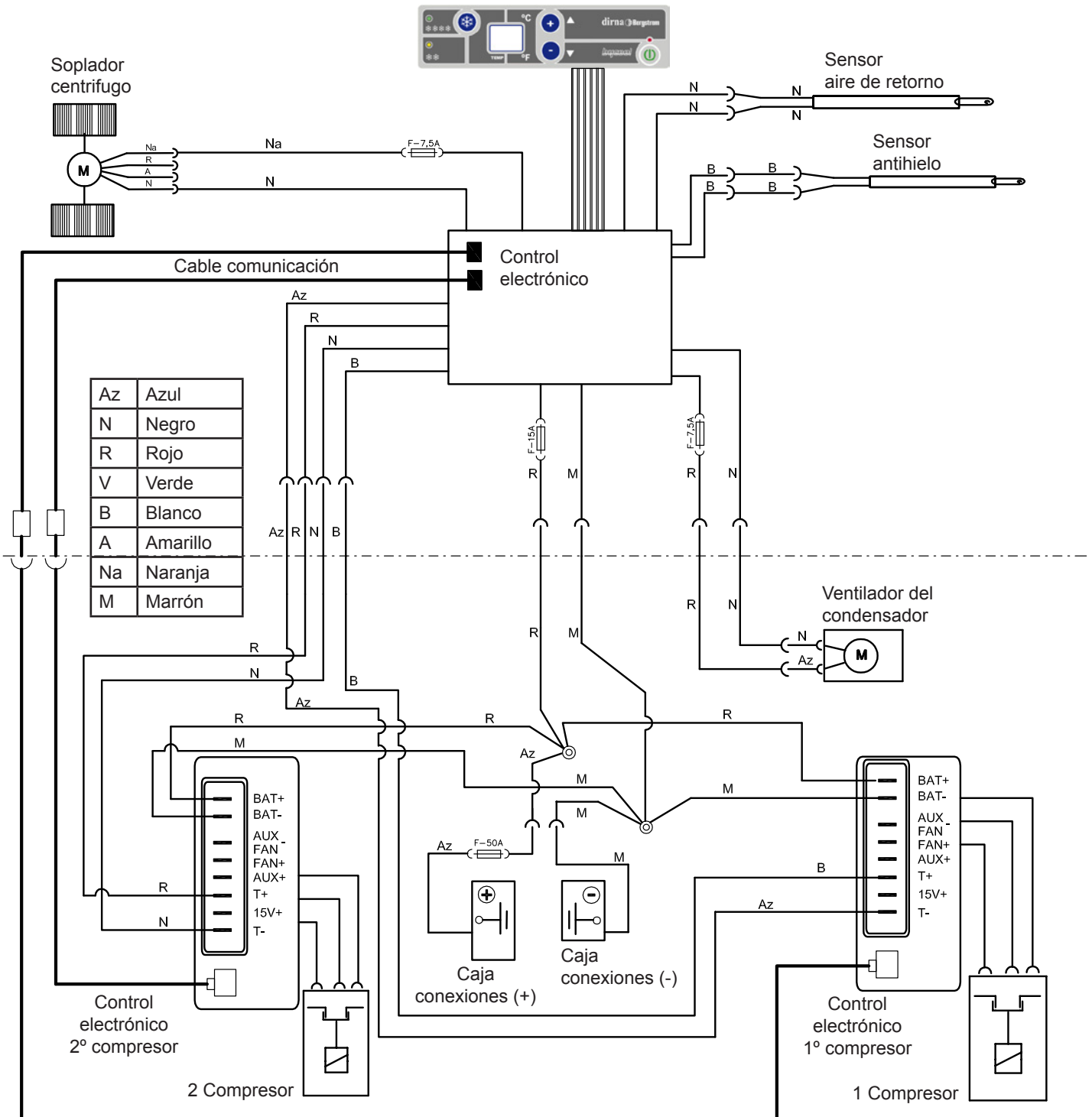

## Assembly Recommendations

- Before starting assembly, please read instructions and follow them during installation process.
- Use the adequate tools for each operation.

## Electricity

- Disconnect ignition key.
- Disconnect battery before starting assembly.
- Make sure electric components are securely connected, checking their correct fitting.

### Warning

If the unit slants during assembly, wait for at least 60 minutes with the unit in horizontal position before starting it up.

### Warning

When installing air conditioning equipment on roof, the upper cabin part must be protected with a cloth or a protective blanket to avoid possible scratches. When installing **Compact** on roof, take into account that, normally, cabins equipped with a hatch have a strong enough structure to hold equipment weight. However, if it is not the case and it is necessary to carry out a cut in the roof or, although it has a hatch, the material is not resistant enough (*if roof is made of fibre, plastic, etc...*), it is the installer who will have to decide, under his responsibility, if it is necessary to reinforce the roof to avoid possible deformations, breaks, water entries, etc., habilitating the means required to stop it from occurring.



## Tools

- Torx wrenches set
- Allen wrenches set
- Open-jawed spanner 10, 13, 14
- Scissors
- Flexo-meter







## Documentation included

Mounting instructions	220.AA2.7002
User's guide	220.AA6.0057
Troubleshooting	220.AA6.0058
Warranty	220.AA1.0017

## Symbology

-  Fragile
-  Beware of cuts!
-  Electrical hazard

## Warnings

-  The installing personnel must have a sufficient training in vehicles air conditioning.
-  **dirna Bergstrom, s.l.** shall not be responsible for breakdowns or damages coming from an inadequate handling or installation of the equipment or from modifications and substitutions carried out without our express and written authorisation.
-  **Equipment pre-charged with refrigerating gas, R-134a. (Do not handle refrigerating gas circuit).**
-  Please see product **warranty procedure** included in **Troubleshooting**.
-  Please see equipment **User's Guide** for its correct functioning of the remote control and control panel.
-  Once installation is finished, the following documents must be handed over to the user: **User's Guide, Warranty and Troubleshooting**.

 Mount the front air input grille before starting assembly.



**1** Take down the hatch cover, the fastening items and set aside.  
(\* ) inner frame.



**2** Remove residual glue substance of the roof upper surface before glueing EPDM gasket.

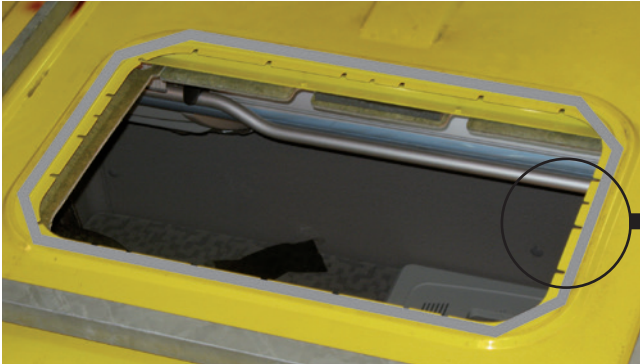

**3** Glue EPDM gasket around hatch hole (see detail for cutting end join edges).

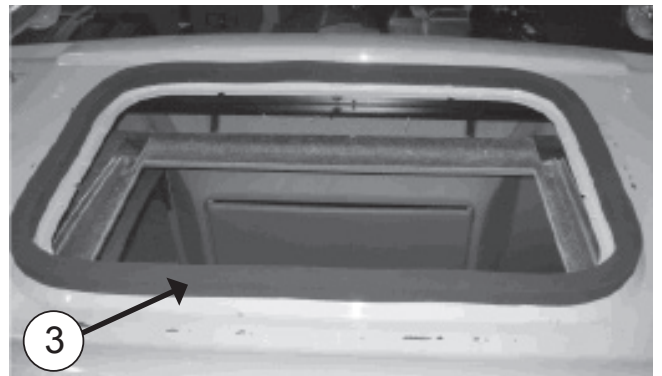

**! HOW TO CUT EPDM GASKET TO AVOID WATER FILTRATION INTO THE CABIN**

**A-** Glue gasket, keeping 100 mm of protection paper at each side.

**B-** Remove the two pieces of paper.

**C-** Glue by pressing both ends.

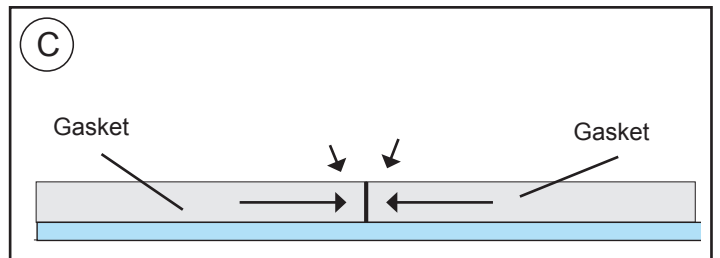
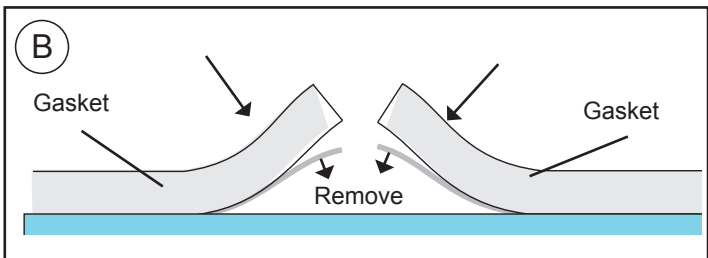
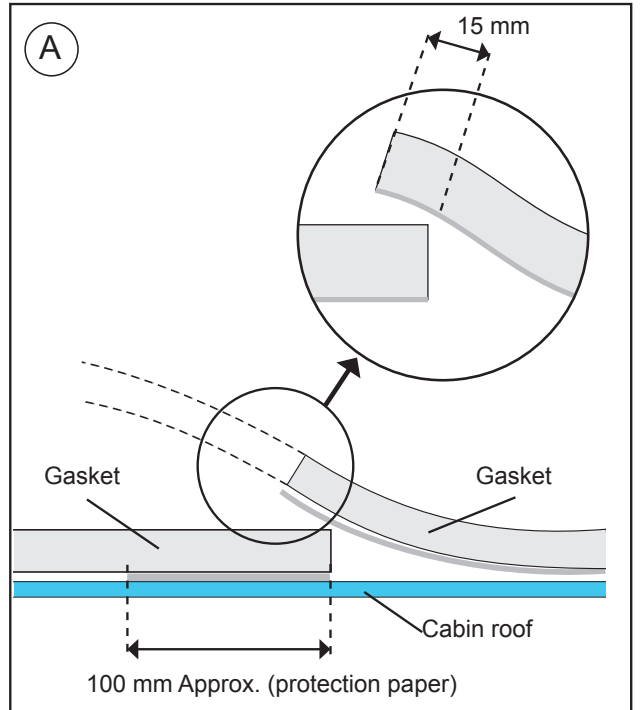



**4** **OUTSIDE CABIN:**  
Position Compact in sun hatch hole.  
**Caution!** When positioning the unit above the hatch gap, check that the wastewater run-offs are not blocked by the EPDM seal.

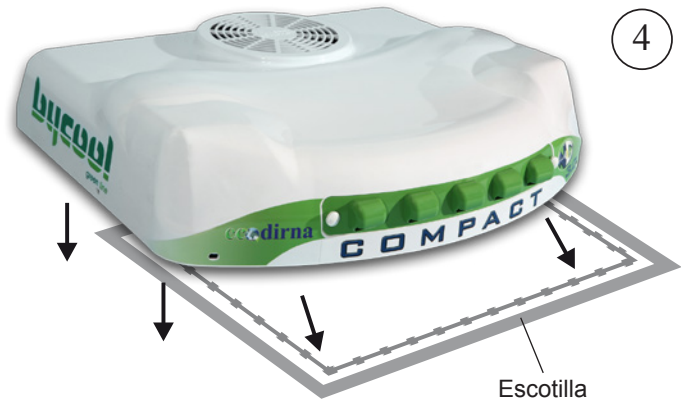

**5** To place the foam rubber ducting remaining at the softer part of the base.

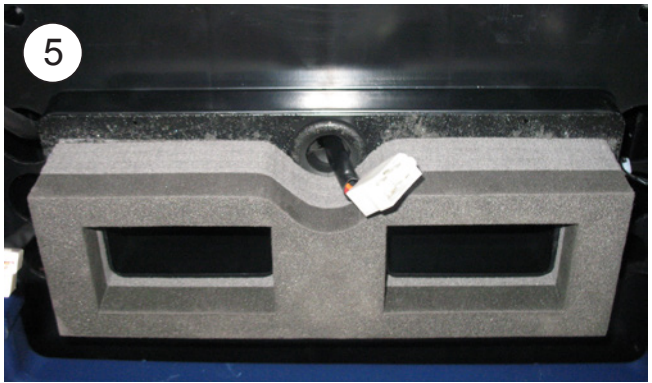

**6** **INSIDE CABIN:**  
Screw about 5 mm (4) 8/125x100 or 120 mm studs, the exact measure is chosen after the fastening supports have been presented and taking into account that studs must stick out of lower part about 20 mm.

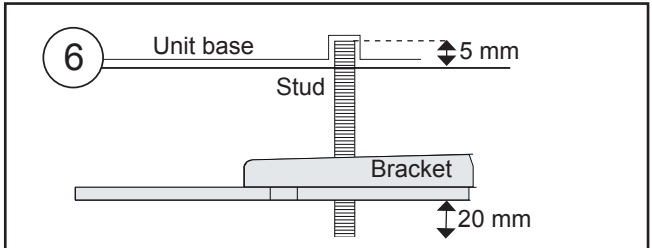

**7** Following this order:  
- Ø 7 plane rubber wash  
- plane rubber wash wide wing diameter 8  
- nut M8  
- plane washer diameter 8 wide wing

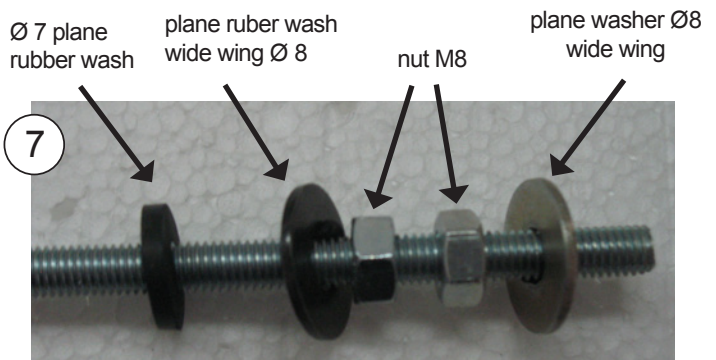

**8** Place (2) fastening supports, with (1) washer and (1) M8 self-blocking nut, **without tightening.**

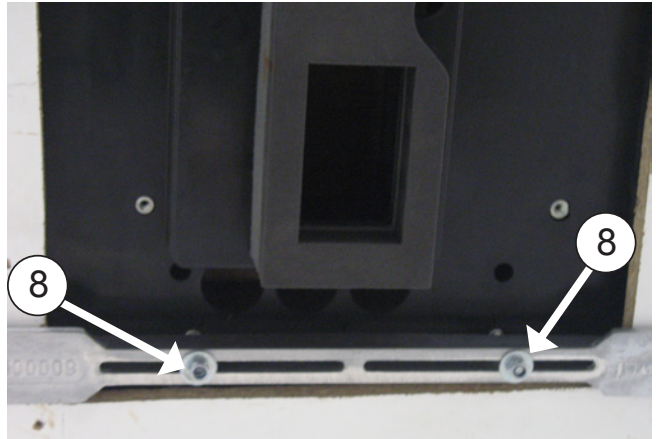
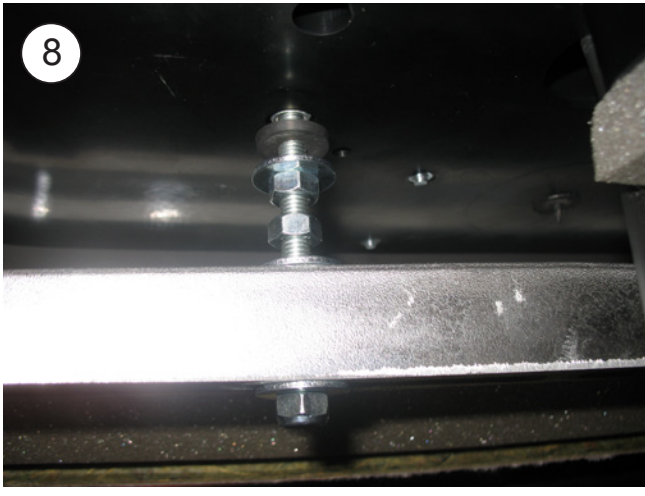

**9** Screw 10 mm deep (4) M6 x 55 or 80 studs, where indicated distance (D) in figure point 11.

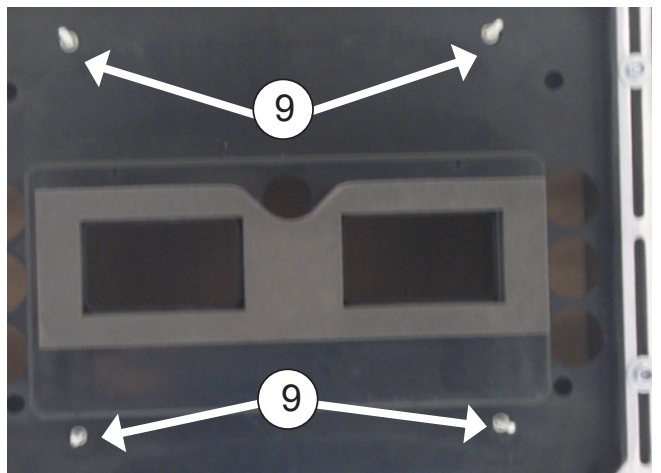
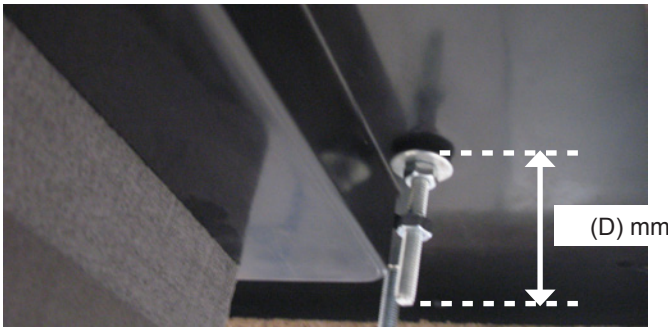

**10** To place (1) rubber washer diameter 6 (1), plane washer diameter 6 wide wing and (1) nut M6, over each of the spigots of M6. After, to tight the nut til the rubber washer remain a little tight.

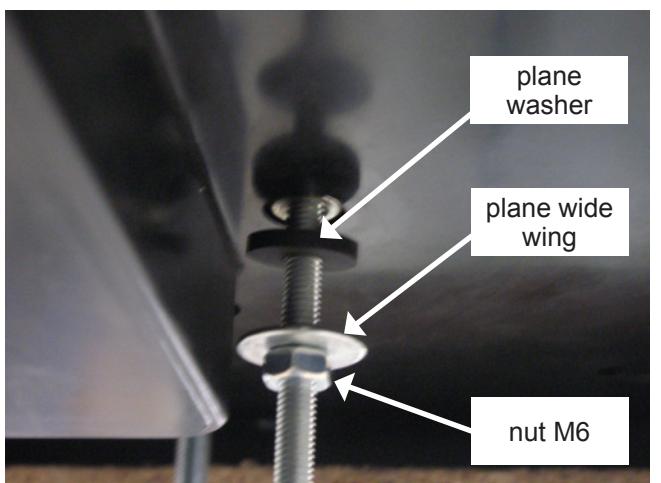



**10a** Place (1) nut M6 without tight in each stud.

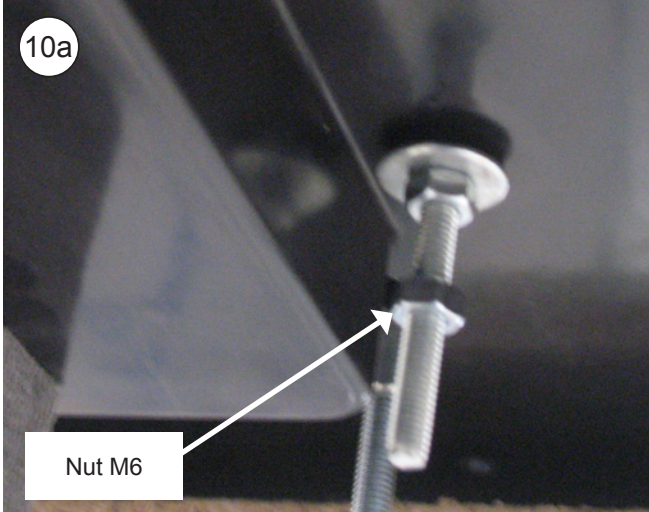

**10b** Connect (2) communication cables (A), the (2) 4-way boxes and (4) 2-way boxes of the interior air distribution panel to those of the Compact.

Bear in mind that the two-way box marked with white cables is joined to the connector with white cables that comes out of the central part of the equipment.

**NOTE: It is very important not to invert the colours of the condenser fan 2-way box (box with R and N wires).**

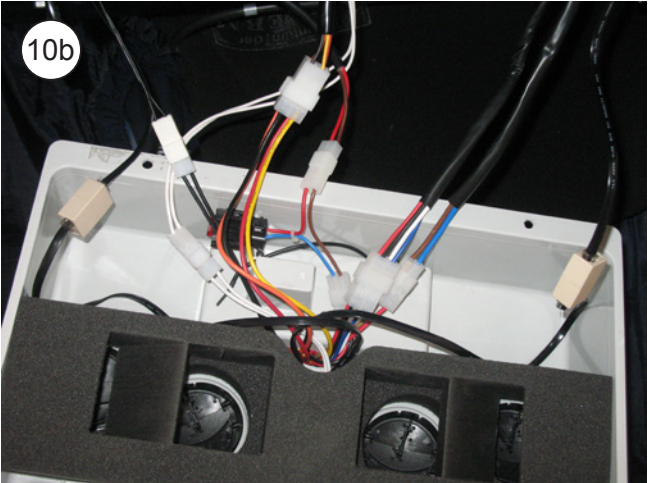

**10c** Introduce the cabling in the gap (H) in the interior air distribution panel in order not to interfere in the adjustment of the ducts with the base of the unit.

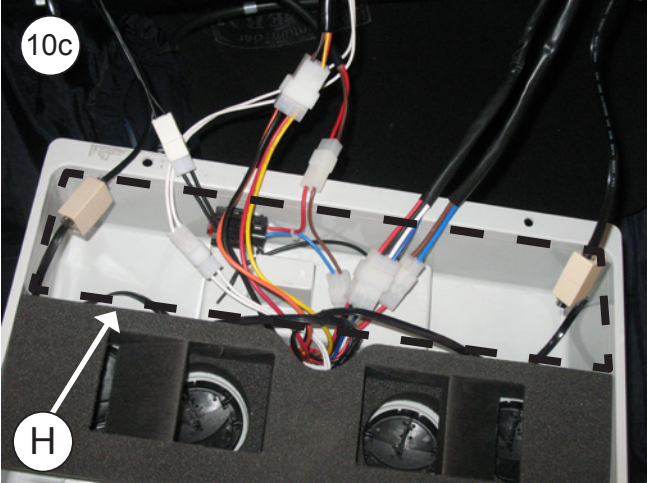



11

Position the interior air distribution panel on the front studs with (1) M6 wide-rimmed washer and (1) M6 nut on each stud. Tighten the nuts until the foam duct comes up against the unit's upper foam.

**IMPORTANT:** The rubber ducting must be run into the upper rubber of the unit to avoid air leaks.

11

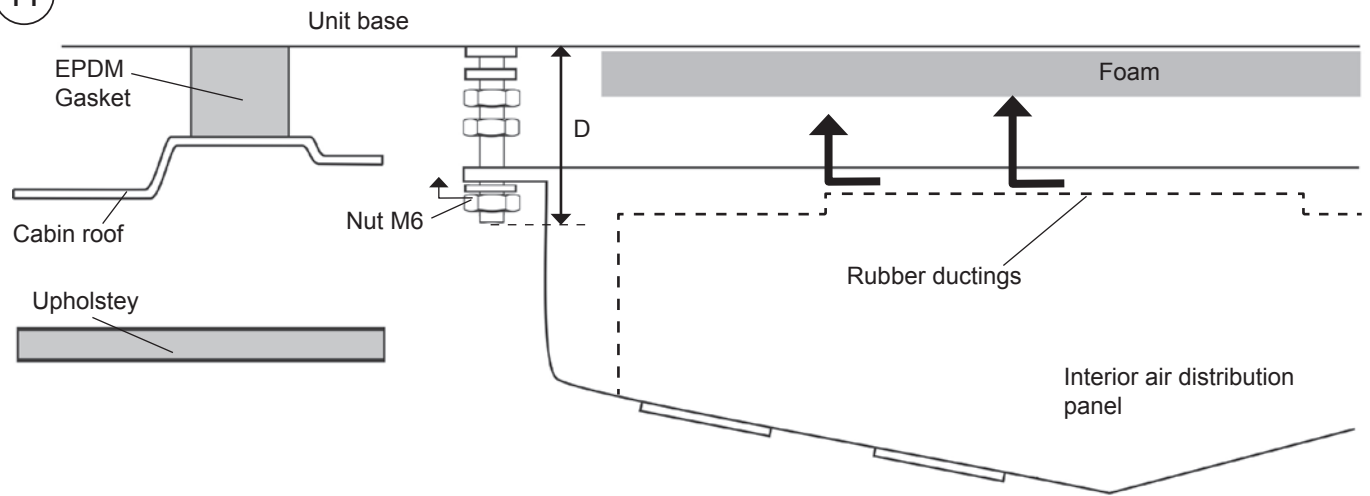

12

Tighten the nut in point 10a until it comes up against the top part of the interior air distribution panel.

12

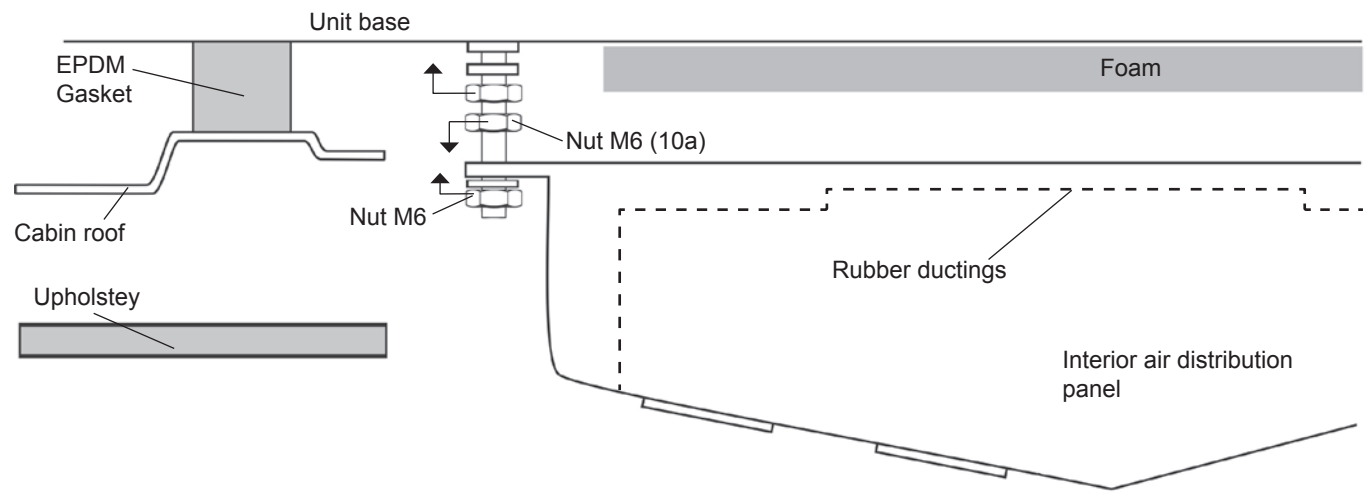

**13** Separate in two halves the original console removing the screws of union between both (placed in the back of the part).



**14** Mount console frame **A** in its original position using the original screws.

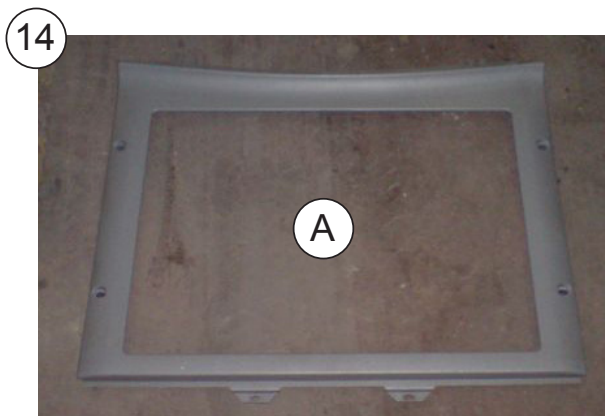

**15** Place the supplied console on the original console frame and align the unit.

**BE SURE THERE IS A GAP BETWEEN THE CONSOLE FRAME AND THE FRONT.**



**16** Fasten supports tightening nuts until outside EPDM joint of equipment is compressed, between 3 and 6 mm.

**Important:** To avoid water from filtering inside cabin, check EPDM joint tightening with unit base, as indicated on **diagram**.



Check compression thickness using a tape measure in the four corners.

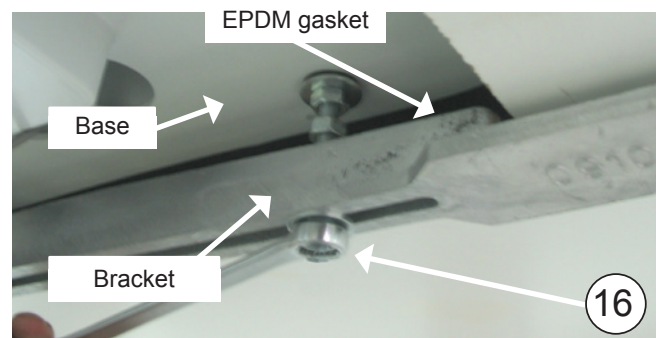
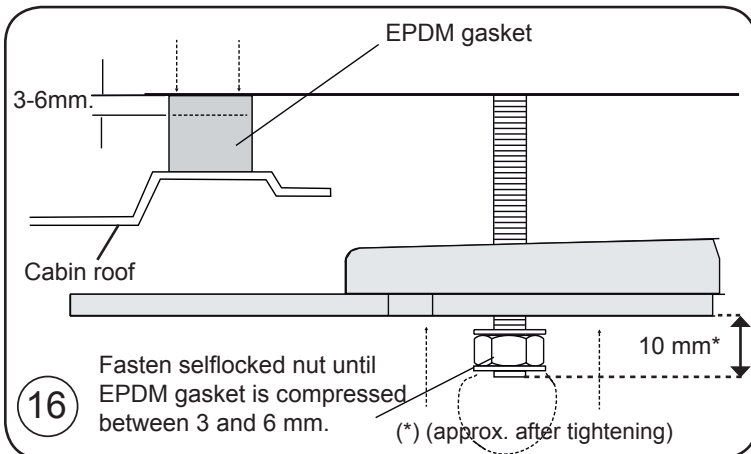

**17** Tighten (4) M8 nuts to support and (4) to Unit base.

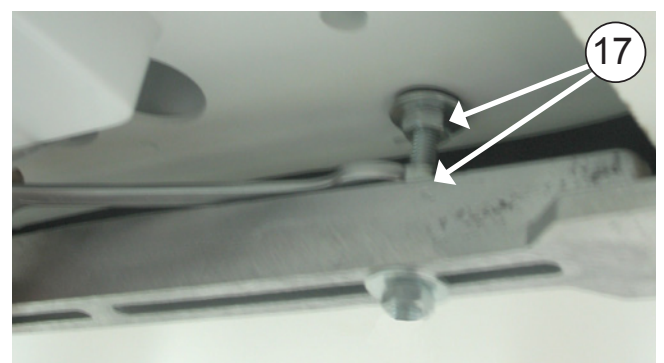



**18**

Bore (8) Ø3 holes and secure the console on the original console frame using (8) self-tapping 3.5x16 screws.

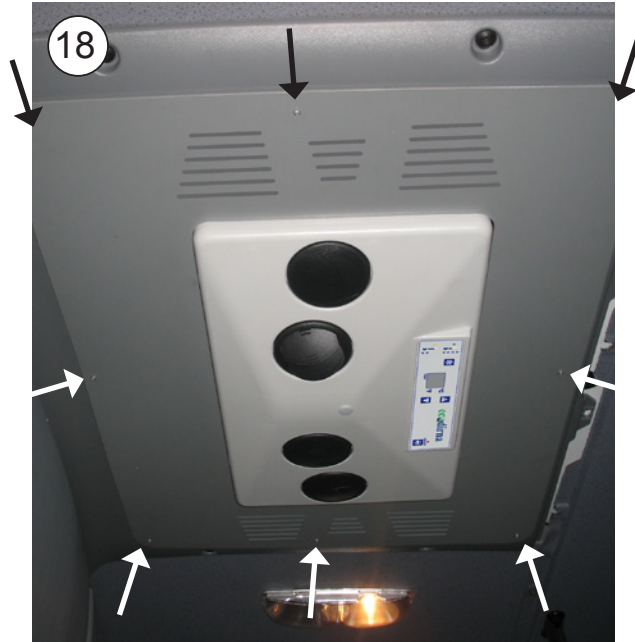

### Exploded side view to supports fastening

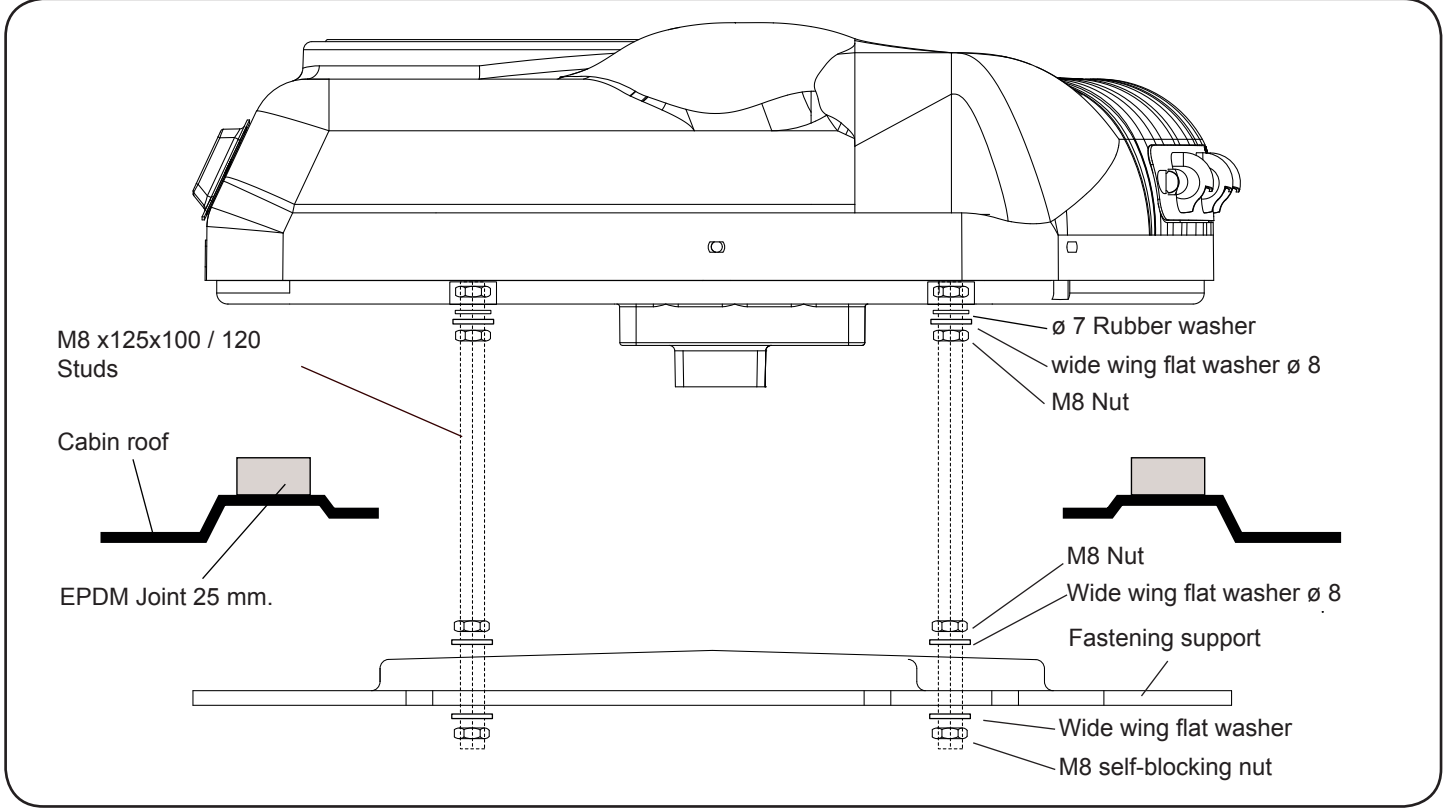

### Exploded rear view to consoles fastening

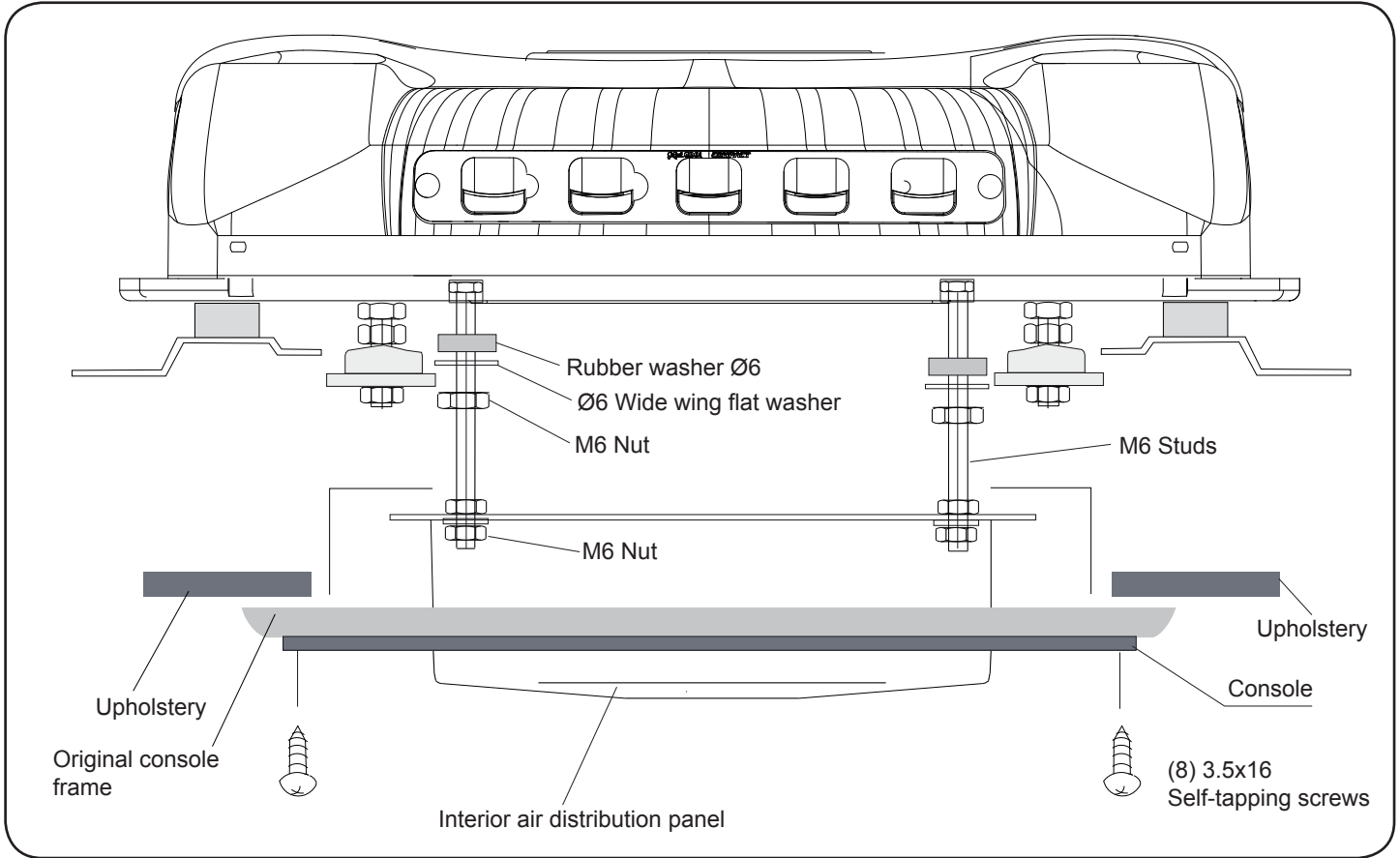

## Detailed instructions on installation of power cables

**1** Connect the upper power cable to the back of the unit and lay it around the back of the cabin, attaching the plastic supports and securing the cable with cable ties.



**2** Connect the lower power cable to the upper power cable terminal.





### Connection to rear batteries

**3** Lay the positive cable (blue) toward the terminal box at X3. Cut and remove any excess cabling, staple the supplied Ø 6 terminal and connect the cable to the fuse section. Secure the cable at X3 with a washer and self-locking nut.

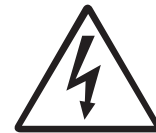
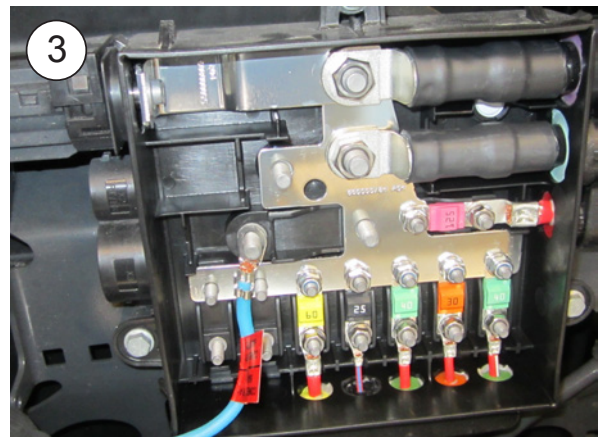
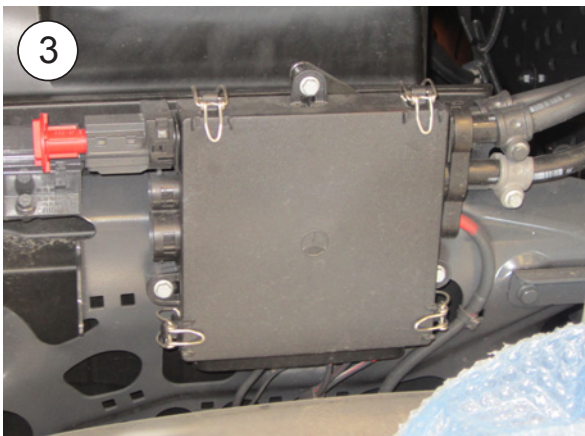
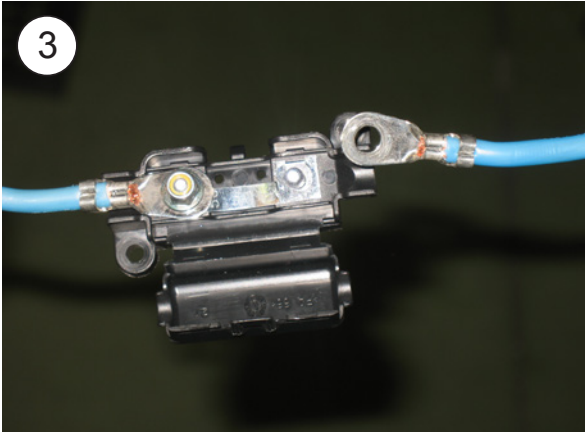
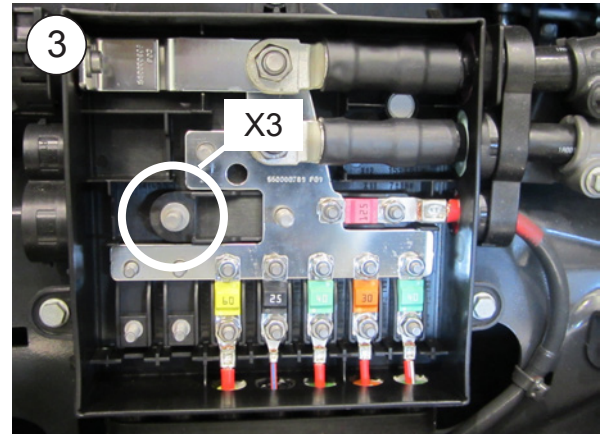

**4** Lay the negative cable (brown) toward the negative terminal box situated near the batteries. Secure the cable with a washer and self-locking nut.



## Front batteries

**3** Lay the positive cable (blue) toward the connections box (situated near the batteries) at X3. Cut and remove any excess cabling, staple the supplied Ø 6 terminal and connect with the supplied fuse section and connect with the fuse section. Secure the cable at X3 with a washer and self-locking nut.

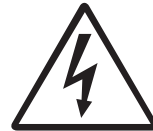
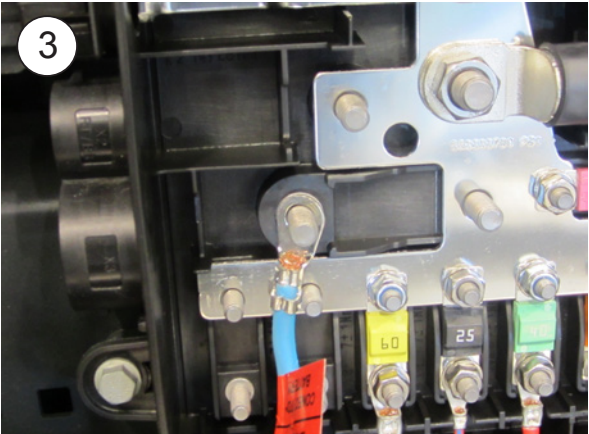

**4** Lay the negative cable (brown) toward the negative terminal box situated next to the negative battery terminal. Cut and remove any excess cabling, staple the Ø 10 terminal and secure the cable with a washer and self-locking nut.

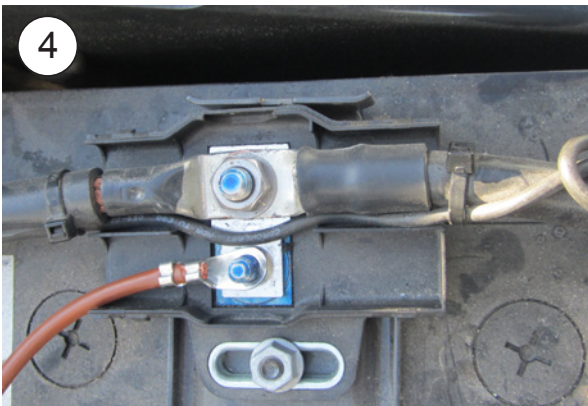
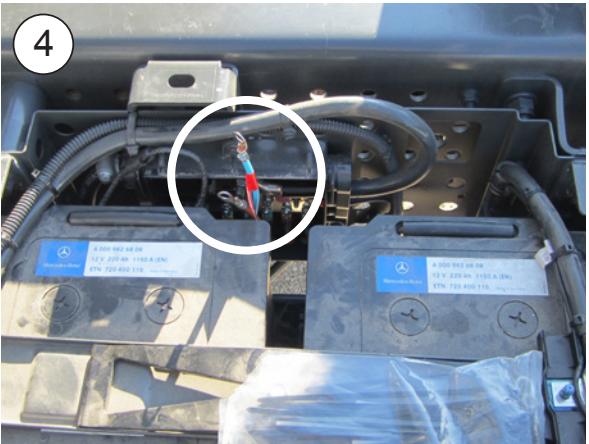



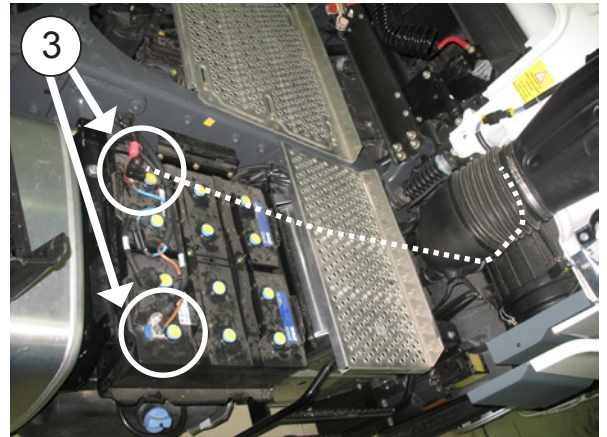

## Direct connection to batteries

**3** Pass the positive and negative cables to the battery through the original cable run and secure with flanges.

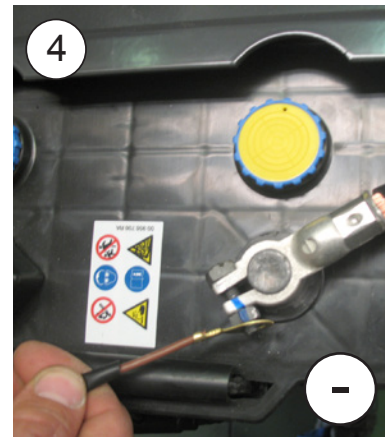
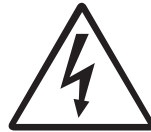

**4** Cut excess cables, clamp the supplied terminals and connect.



 **CAUTION:** When connecting the cables, make sure that you leave enough room to ensure that the cabin's movements do not cause the cabling to break!  
**IMPORTANT:** For starting up the unit, please see the user manual.

**5** Place danger stickers at the cable junction and the cabin lifting device.





Electric wiring

IMPORTANT WARNING!

Take care not to invert polarities when connecting the unit to the power supply. If this were to happen, the unit will not work and irreparable damage will be caused to the compressor modules.

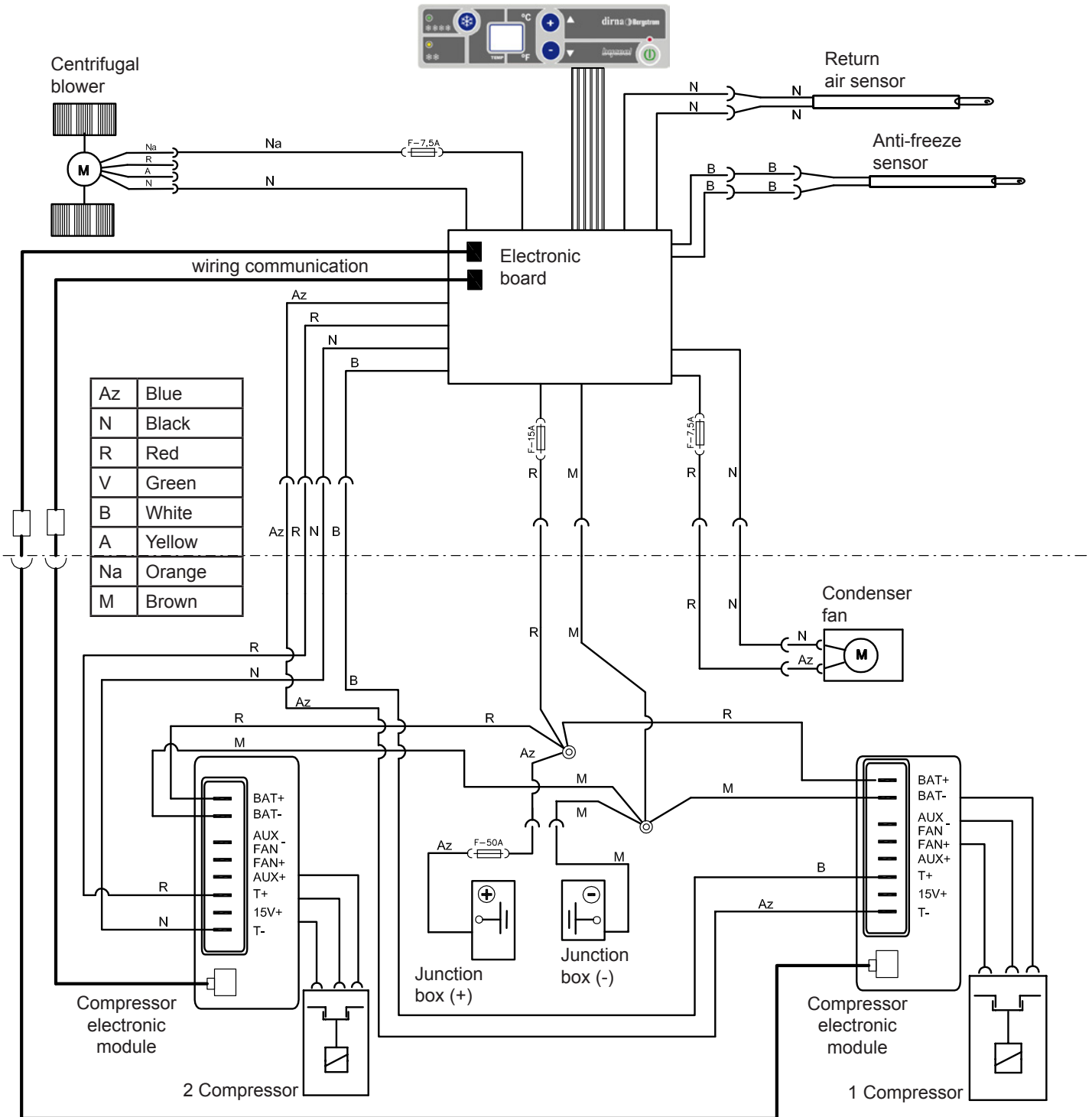

## Recommandations Pour Le Montage

- Avant de commencer le montage de l'appareil, prière de lire les instructions et de les suivre attentivement.
- Utiliser les outils convenant à chaque opération.

## Electricity

- Déconnecter la clé de contact.
- Déconnecter la batterie avant de commencer le montage.
- Vérifier le câblage des composants électriques et leur correcte installation.

### Attention

**Si pendant le montage l'équipement est incliné, il faudra attendre au moins 60 minutes avant de le mettre en marche une fois qu'il aura été remis sur sa position horizontale.**

### Attention

Lors de l'installation de l'appareil d'air conditionné sur le toit, il faudra protéger la partie supérieure de la cabine avec un linge ou une couverture de protection afin d'éviter les éventuelles égratignures.

Durant l'installation du **Compact**, tenir compte du fait que normalement les cabines pourvues d'écoutille possède une structure suffisamment solide pour supporter le poids de l'appareil. Cependant, si ce n'est pas le cas et qu'il est nécessaire de découper le toit ou même si disposant d'écoutille, la structure n'est pas suffisamment rigide (si elle était en fibre, plastique, etc.) il appartiendra à l'installateur de décider s'il faut renforcer le toit pour éviter toute déformation, rupture ou voie d'eau, etc., et prendre les mesures nécessaires à cet effet.

## Outils

Jeu de clés Torx

Jeu de clés Allen

Clé fixe 10, 13, 14

Ciseaux

Mètre

## Documentation included

Instructions de montage	220.AA2.7002
Guide de l'utilisateur	220.AA6.0057
Solution des problèmes	220.AA6.0058
Garantie	220.AA1.0017

## Symbologie



Fragile



Attention aux coupures !



Risque électrique

## Garantie



L'installateur devra posséder la formation pertinente en air conditionné sur véhicules.



**dirna Bergstrom, s.l.**, ne sera pas responsable des dommages ou des bris dérivés d'une installation ou d'une manipulation incorrecte ni des modifications réalisées sans autorisation expresse par écrit.



**Appareil pré-chargé de gaz réfrigérant, R-134. (Ne pas manipuler le circuit de gaz réfrigérant).**



Voir la **procédure de garantie** du produit au **Diagnostic de problèmes**.



Voir le **Guide de l'Usager** de l'appareil pour le fonctionnement correcte de la télécommande et du tableau de commande.



Après l'installation, vous devez fournir à l'utilisateur: Manuel d'utilisation, garantie et diagnostic de pannes.

 Avant de commencer le montage, monter la grille d'entrée d'air frontale.



**1** Démontez le couvercle de l'écouille, les éléments de fixation et réservez.  
 (\*) Cadre intérieur.





**2** Eliminer les restes d'adhésif de la surface supérieure de la cabine avant de coller le joint EPDM.

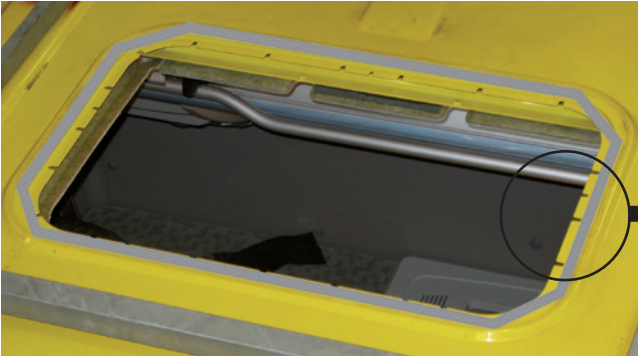

**3** Coller le joint EPDM autour de l'orifice de l'écouille (voir détail pour découper les bords).

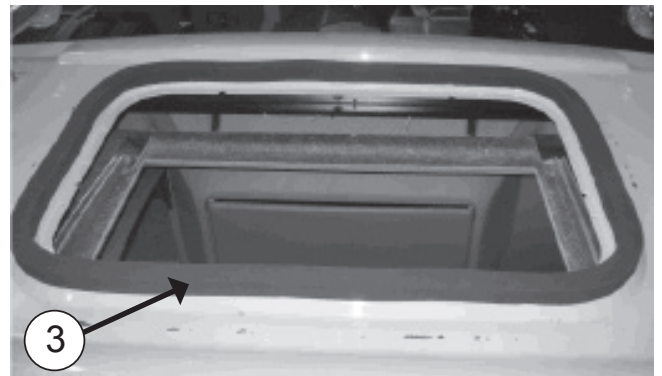

**! COMMENT COUPER LE JOINT EPDM POUR EVITER LES FILTRATIONS DANS LA CABINE**

**A-** Coller le joint en maintenant une protection en papier de 100 mm de chaque côté.

**B-** Retirer les deux morceaux de papier.

**C-** Coller en faisant pression sur les deux extrémités.

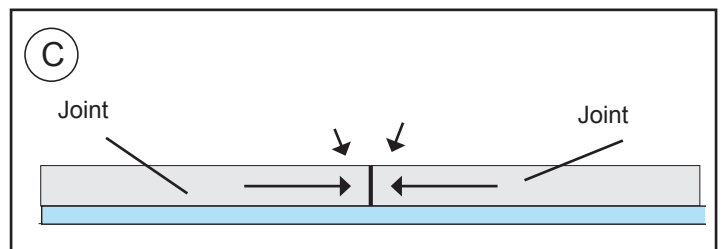
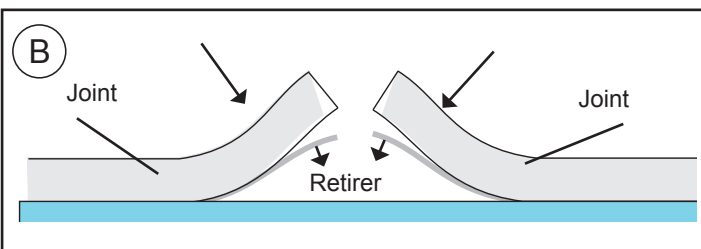
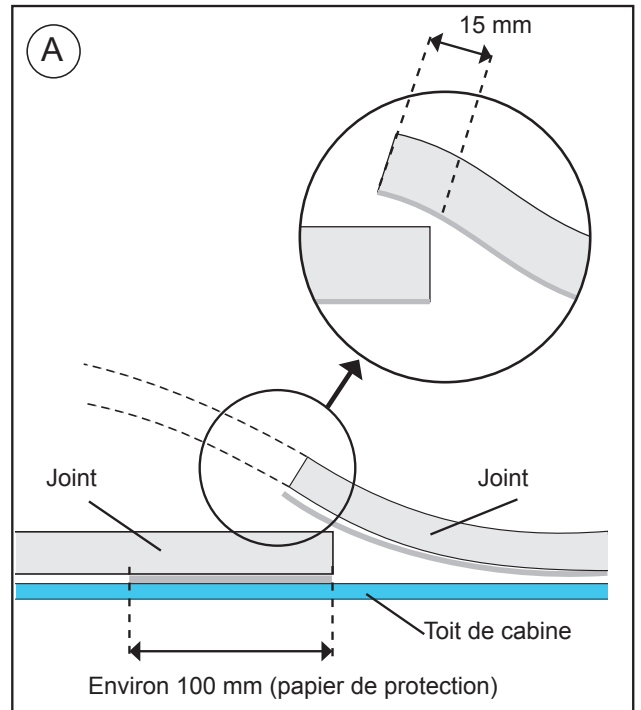

**4** **EXTERIEUR CABINE:**  
Positionner le Compact dans l'espace prévu.  
**Attention ! Avant de placer l'équipement sur le creux de l'écouille, vérifier que les sorties d'écoulement ne soient pas bouchées par le joint EPDM.**

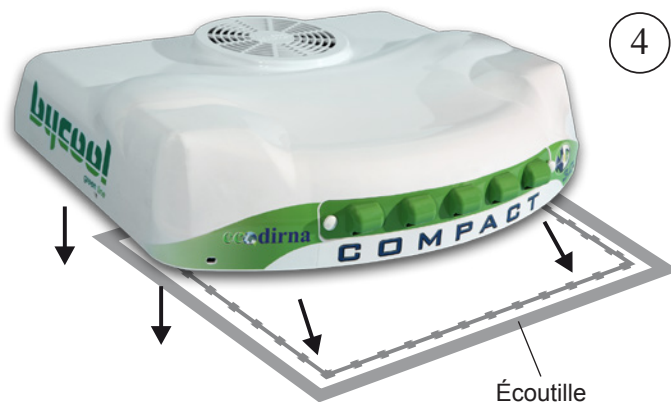

**5** Placer les canalisations a mousse en restant la part plus molle sous la base d'équipement.



**6** **INTERIEUR CABINE:**  
Visser 5 mm environ (4) goujons de 8/125x 100 ou 120 mm, en fonction de la distance plus ou moins grande de l'appareil jusqu'à ce qu'en positionnant les supports de fixation, il ne reste que 20 mm au-dessous de ces supports.

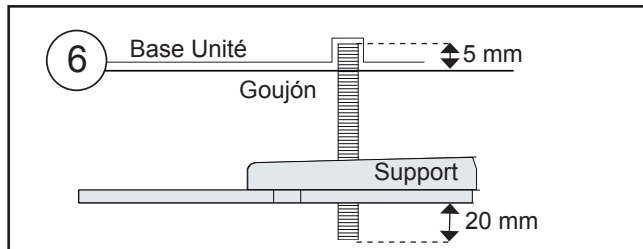

**7** en suivant cet ordre :  
- rondelle a mousse  
- rondelle plain diamètre 8 aile large  
- écrou M8  
- plain rondelle diamètre 8 aile large

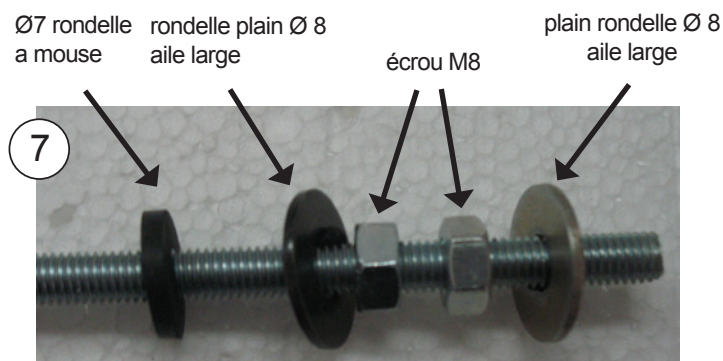

8

Placer les supports de fixation (2), avec une rondelle (1) et un écrou autobloquant (1) M8, sans serrer.

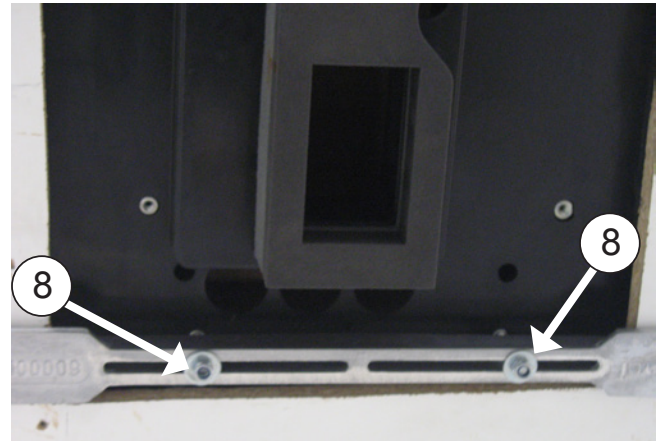
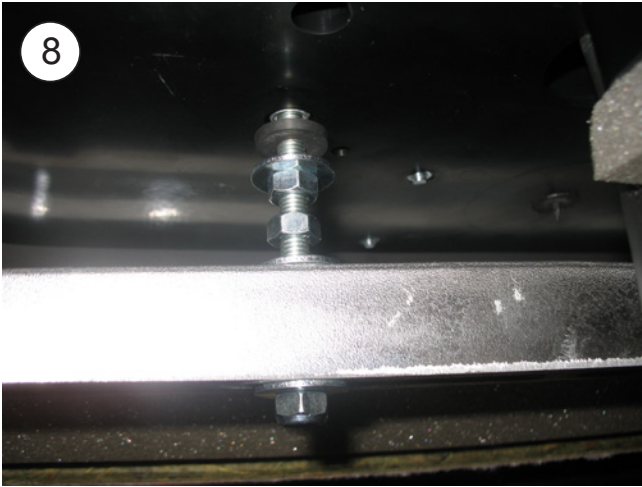

9

Visser 10 mm les goujons (4) M6 x 55 ou 80, comme indiqué au (D) du schéma point 11.

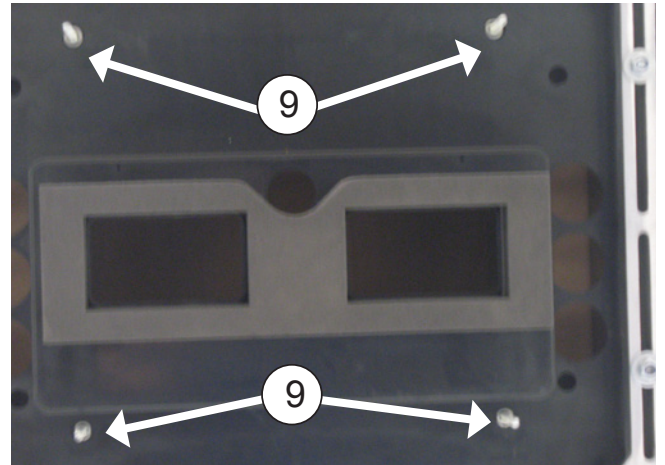
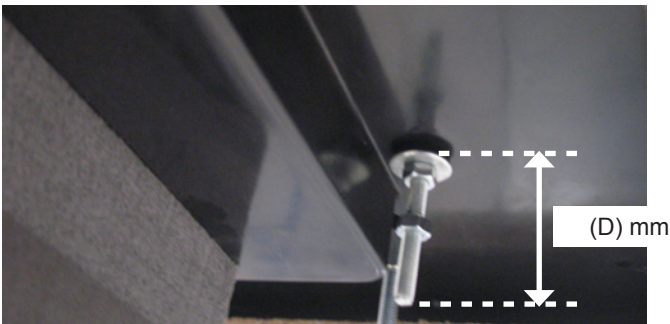

10

Placer (1) rondelle mouse diamètre 6 (1) plain rondelle diamètre 6 aile large et (1) écrou M6 sur chacun des asperges M6. En suivant serrer l'écrou jusqu'à la rondelle à mouse reste un peu pressée.

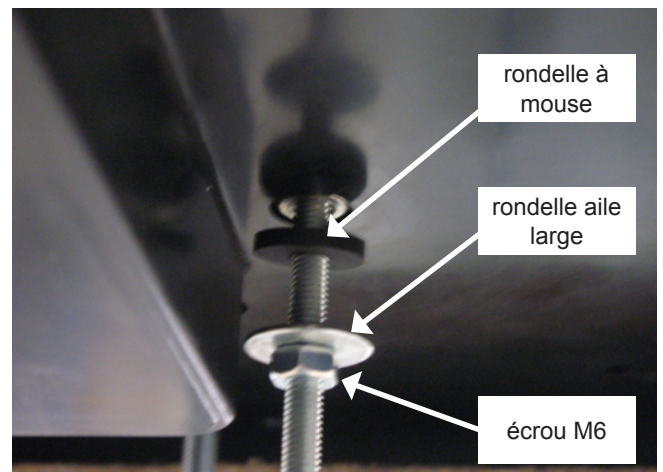



**10a**

Placer l'écrou (1) M6 sans le serrer sur chaque goujon.

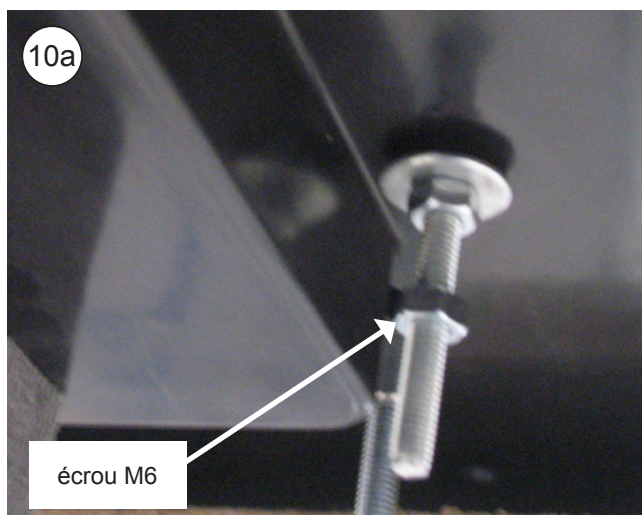
**10b**

Connecter (2) câbles de communication (A), (2) boîtiers à 4 voies et (4) à 2 voies du panneau intérieur de distribution d'air à ceux du **Compact**.

Compte tenu du fait que le boîtier à deux voies marqué avec deux câbles blancs rejoint le connecteur à câbles blancs qui vient de la partie centrale de l'équipement.

**ATTENTION : il est très important de ne pas inverser les couleurs de la boîte à 2 voies du ventilateur du condenseur (boîte avec câbles R et N).**

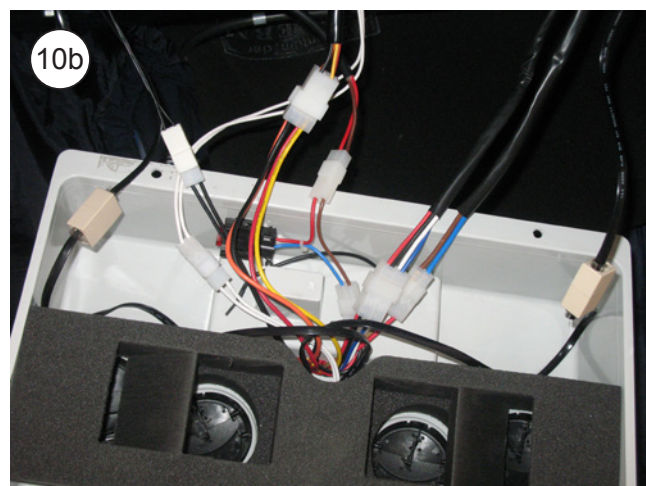
**10c**

Introduire les câblages dans le creux existant (H) du panneau intérieur de distribution d'air pour ne pas interférer dans le réglage des canalisateurs avec la base de l'équipement.

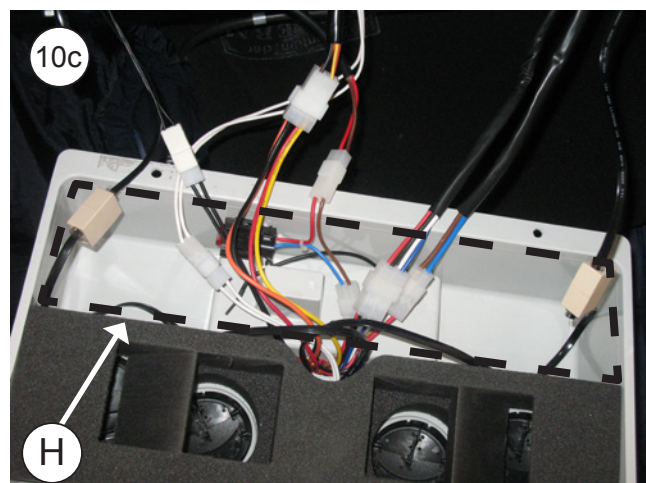

11

Placer le panneau intérieur de distribution d'air dans les goujons précédents avec (1) rondelle M6 surface large et (1) écrou M6 sur chaque goujon. Serrer les écrous jusqu'à ce que le canalisateur en caoutchouc mousse atteigne le caoutchouc mousse supérieur de l'équipement.

**Important: La canalisation a mousse doit faire butoir contre la mousse supérieure d'équipement pour éviter fuites d'air.**

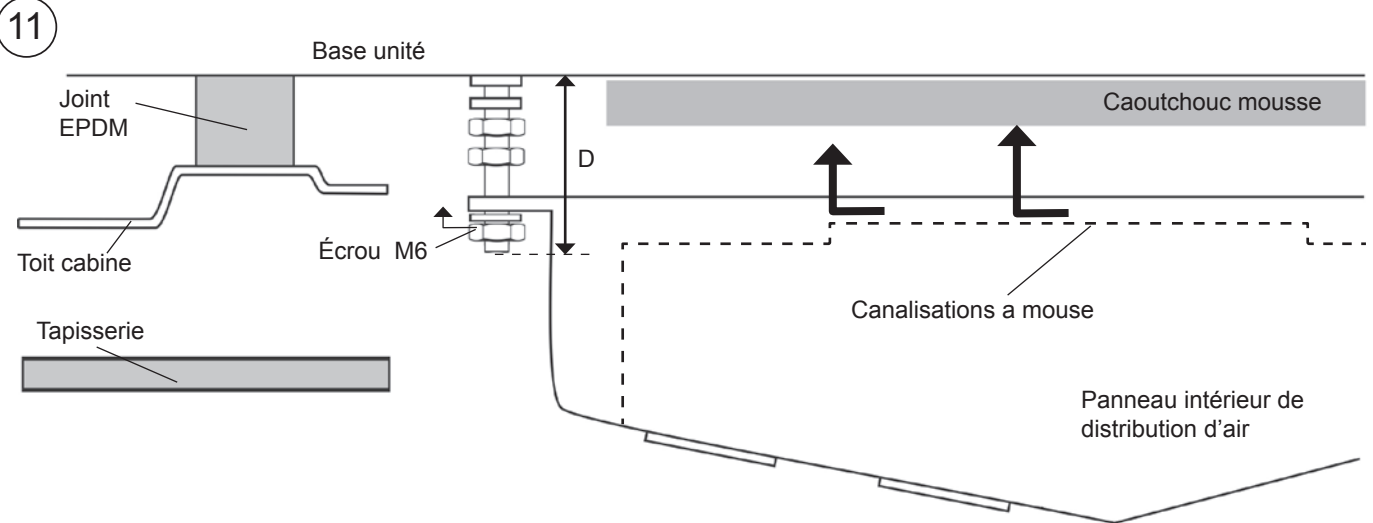

12

Serrer l'écrou du point 10a jusqu'à atteindre la partie supérieure du panneau intérieur de distribution d'air.

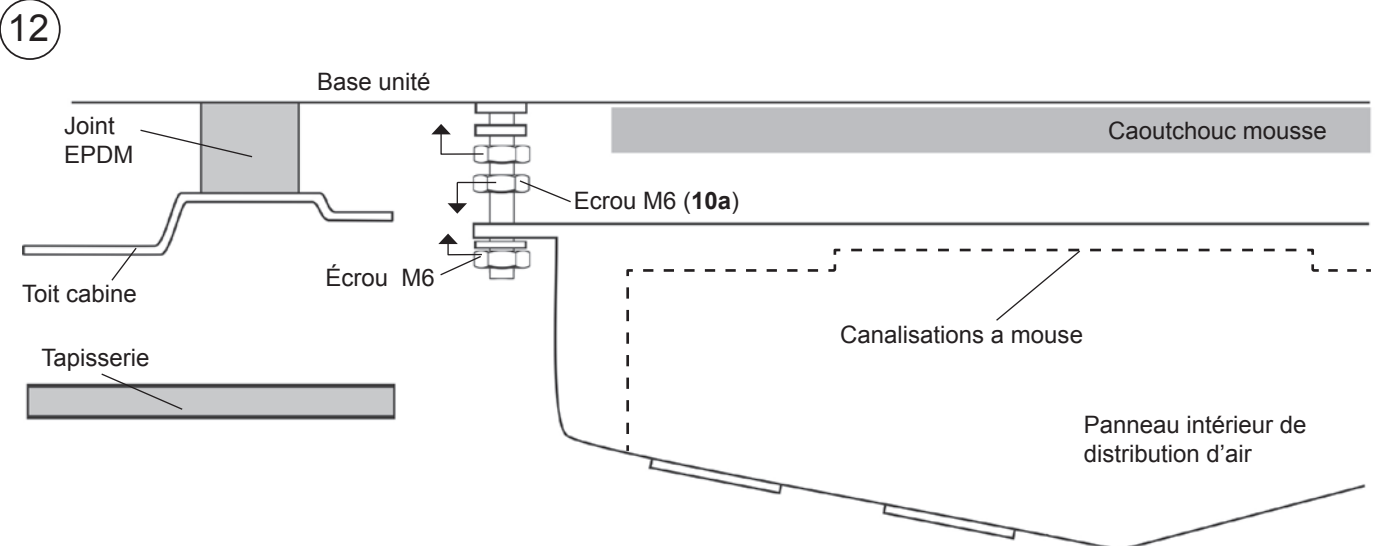

**13** Séparer en deux bornes d'origine, démonter l'union entre les deux vis situées à l'arrière.



**14** Monter le cadre de la console A avec les vis d'origine sur sa position d'origine.

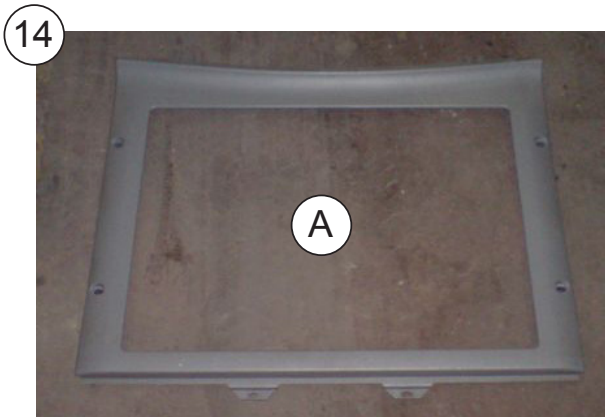



15

Présenter la console fournie sur le cadre de la console d'origine et centrer l'équipement.

**ATTENTION : IL FAUT COUVRIR LE CREUX EXISTANT ENTRE LE CADRE DE LA CONSOLE ET LA PARTIE FRONTALE.**



16

Fixer les supports en serrant les écrous jusqu'à serrer le joint EPDM de l'appareil entre 3 et 6 mm.

**Important:** Pour éviter la filtration d'eau dans la cabine, vérifier le serrage du joint EPDM à la base du **Compact**, comme indiqué sur le **diagramme**.



Vérifier la compression du joint EPDM en utilisant un flexomètre dans les quatre coins.

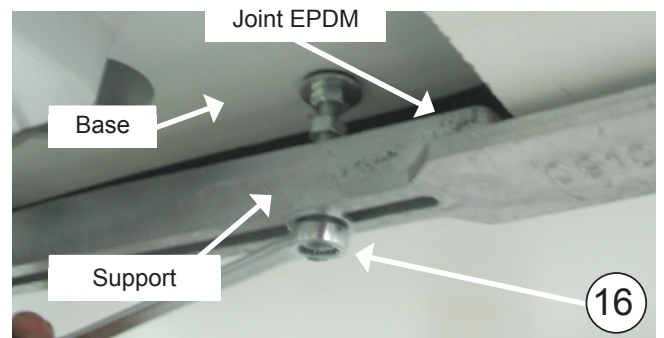
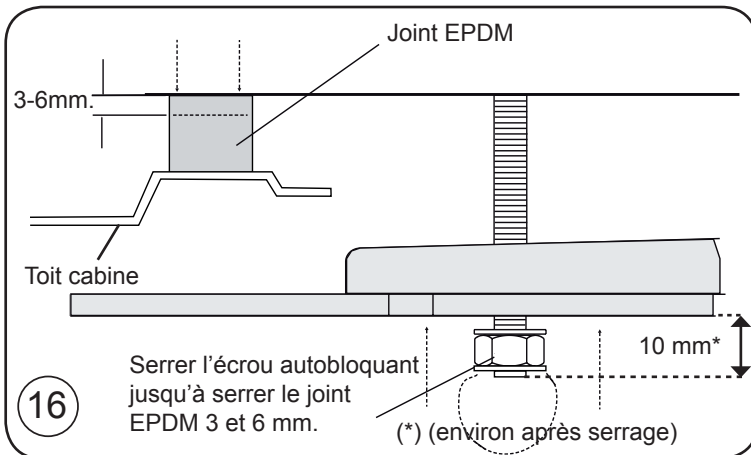

17

Serrer les écrous (4) M8 afin de fixer à (4) l'unité base.

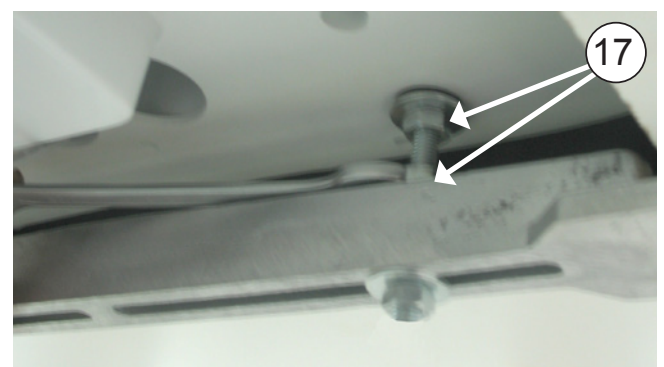

**18**

Fixer la console sur le cadre de la console d'origine avec (8) vis taraudeuses 3,5x16, après avoir réalisé préalablement (8) trous Ø 3.

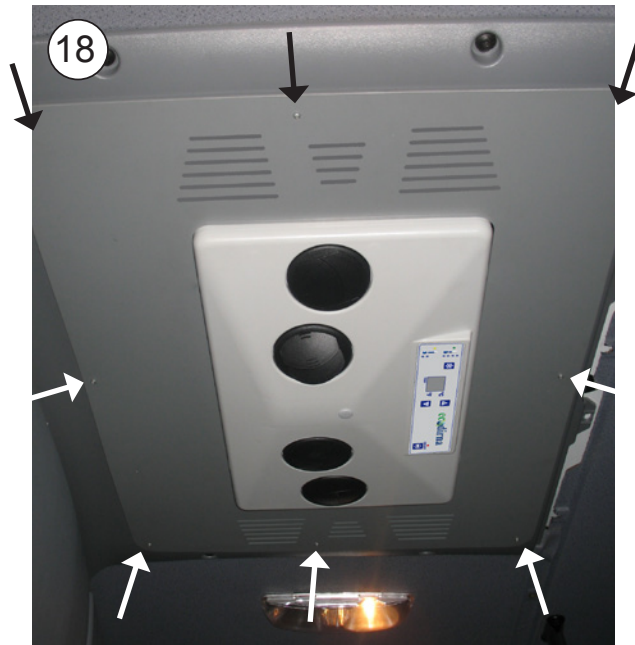

**Vue explosée jusqu'à la fixation des supports de fixation**

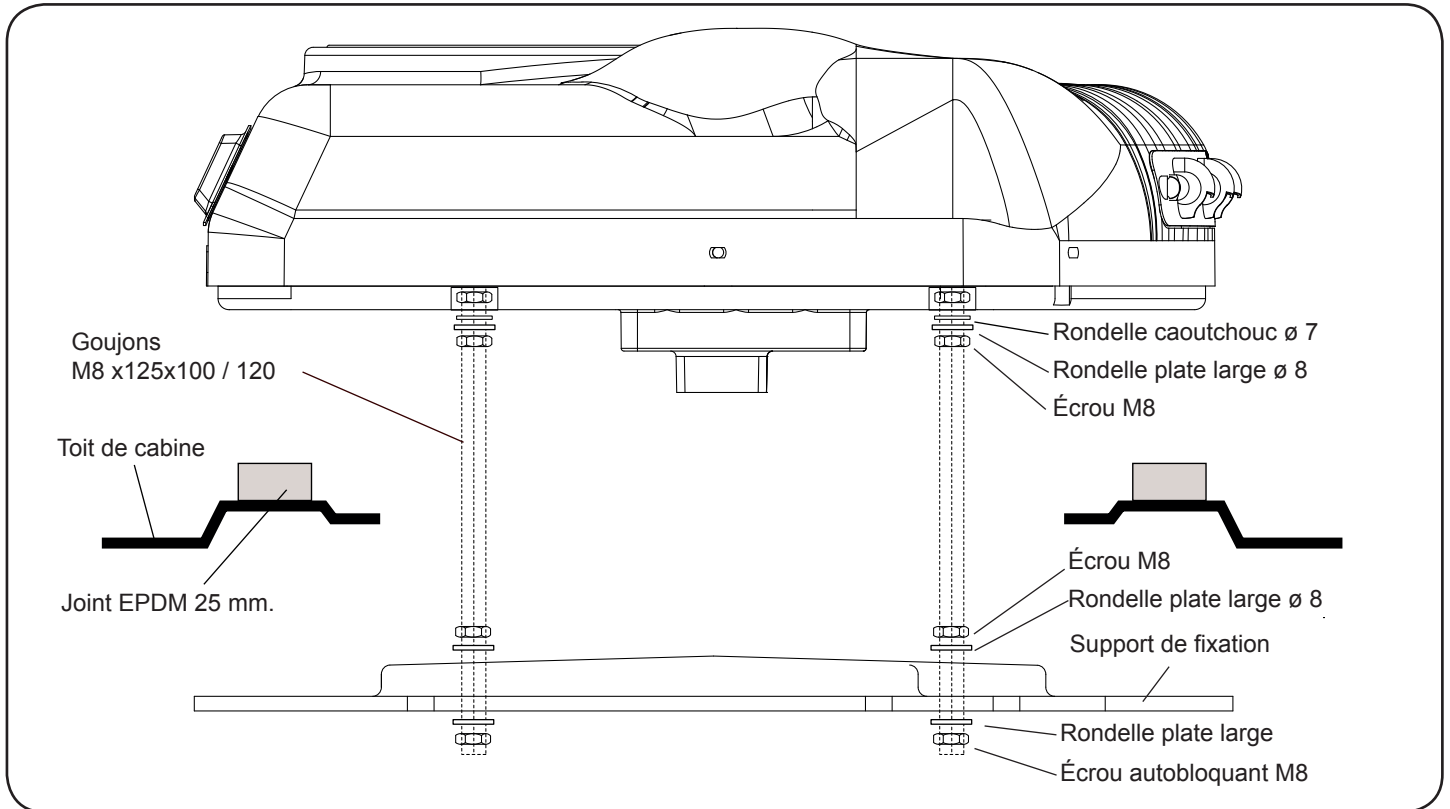

**Vue explosée jusqu'à fixation des consoles**

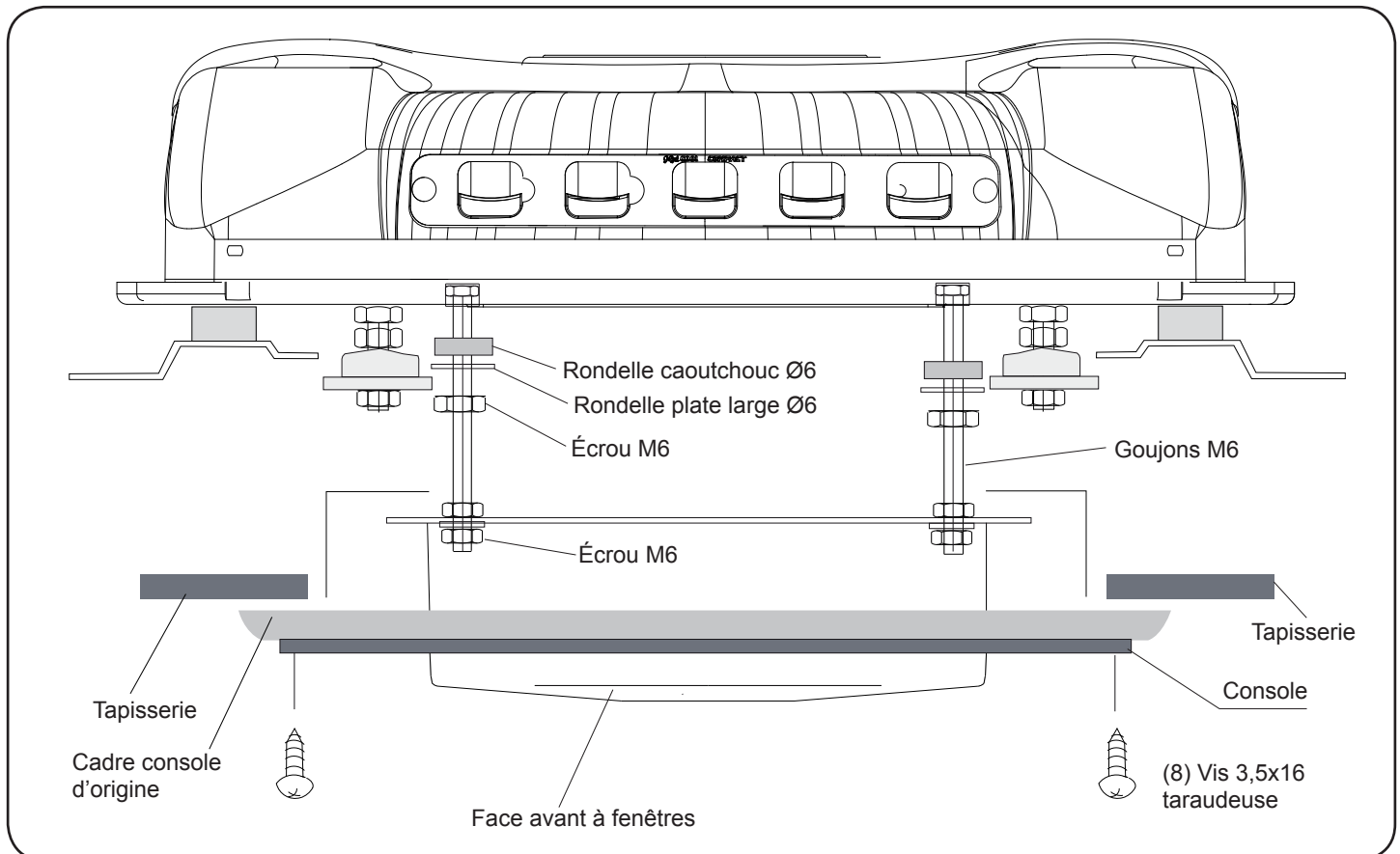



## Instructions détaillées sur l'installation du câblage d'alimentation

**1**

Connecter le câble d'alimentation supérieur à la partie arrière de l'équipement et le porter par la partie postérieure de la cabine en collant les supports en plastique et en le fixant avec des brides.

**2**

Connecter le câblage d'alimentation inférieur à la borne du câblage d'alimentation supérieur.



## Connexion aux batteries arrière

- 3** Porter le câble positif (bleu) à la boîte de jonction sur la position X3. Couper le câble restant, agraffer le terminal Ø 6 fourni et le connecter au tronçon du fusible. Fixer le câble sur la position X3 avec une rondelle et un écrou autobloquant.

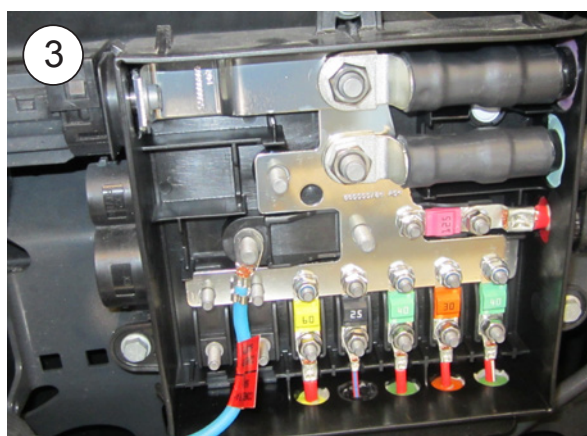
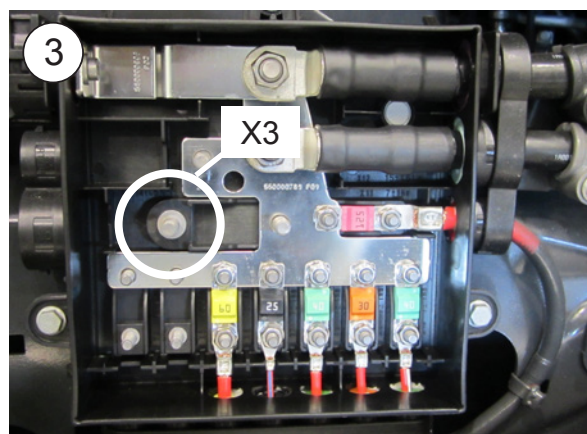
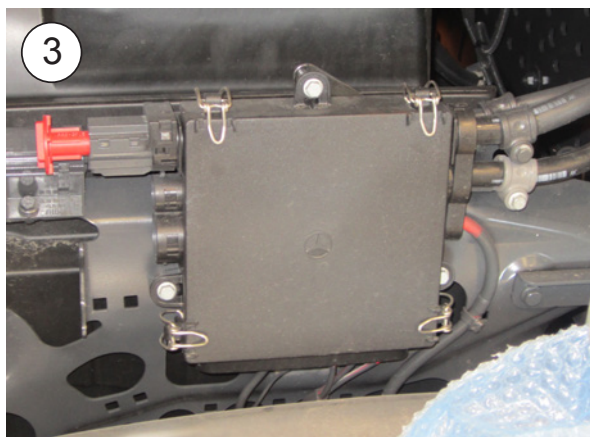
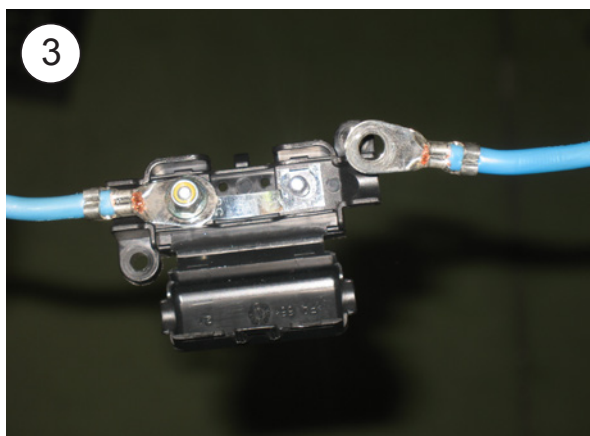

- 4** Porter le câble négatif (marron) à la boîte de jonction négative située près des batteries. Fixer le câble avec une rondelle et un écrou autobloquant.





## Batteries frontales

**3** Porter le câble positif (bleu) à la boîte de jonction (située près des batteries) sur la position X3. Couper le câble restant, agraffer le terminal Ø 6 fourni et le connecter au tronçon du fusible. Fixer le câble sur la position X3 avec une rondelle et un écrou autobloquant.

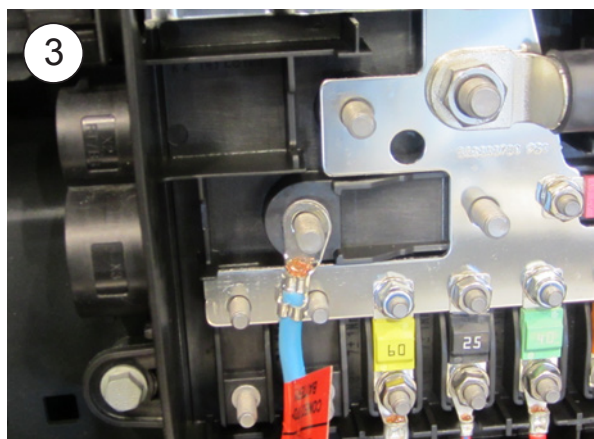
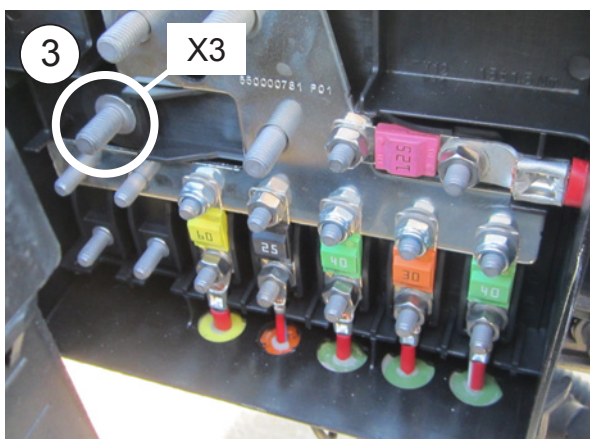
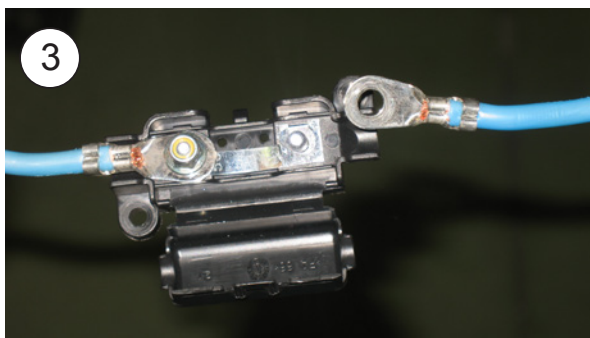

**4** Porter le câble négatif (marron) à la boîte de jonction négative située à côté de la borne négative de la batterie. Couper le câble restant et agraffer le terminal Ø 10, puis fixer avec une rondelle et un écrou autobloquant.

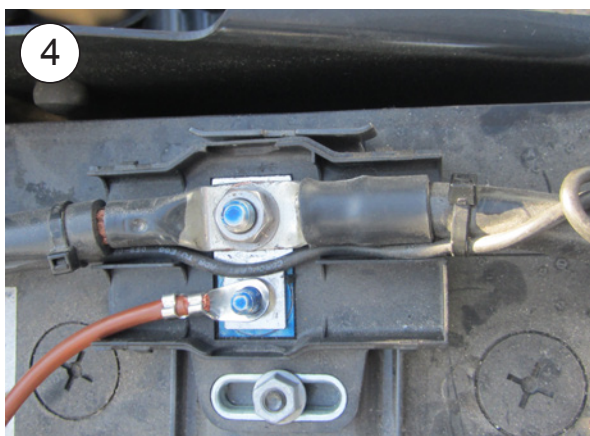



## Connexion directe aux batteries

3

Porter les câblages positif et négatif à la batterie en les passant par le passage d'origine des câblages et en les fixant avec des brides.

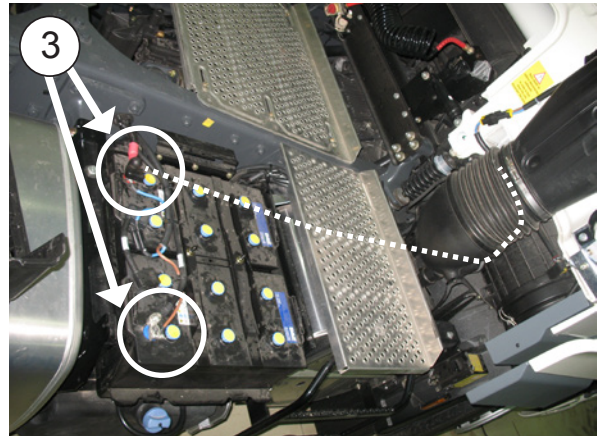

4

Couper le câble restant, agraffer les terminaux fournis et connecter.

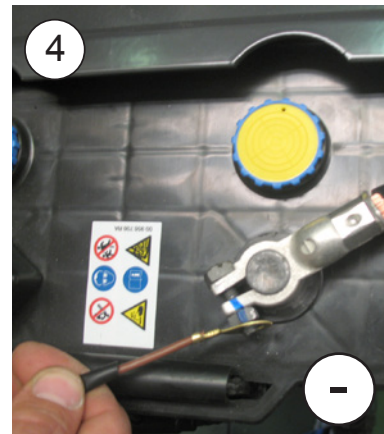

**ATTENTION** : au moment de la connexion des câblages, il faut prévoir une distance suffisante pour éviter des dommages en raison des mouvements de la cabine !

**IMPORTANT** : consultez la notice avant la mise en marche.

5

Placer des adhésifs de danger sur l'union du câblage et sur le dispositif de levage de cabine.



# Câblage électrique

## AVERTISSEMENT IMPORTANT!

**Attention !** Ne pas inverser les polarités dans la connexion de l'alimentation à l'équipement. Si cela se produisait, la plaque ne s'allumerait pas, l'équipement ne fonctionnerait pas et des dommages irréparables se produiraient sur les modules des compresseurs.

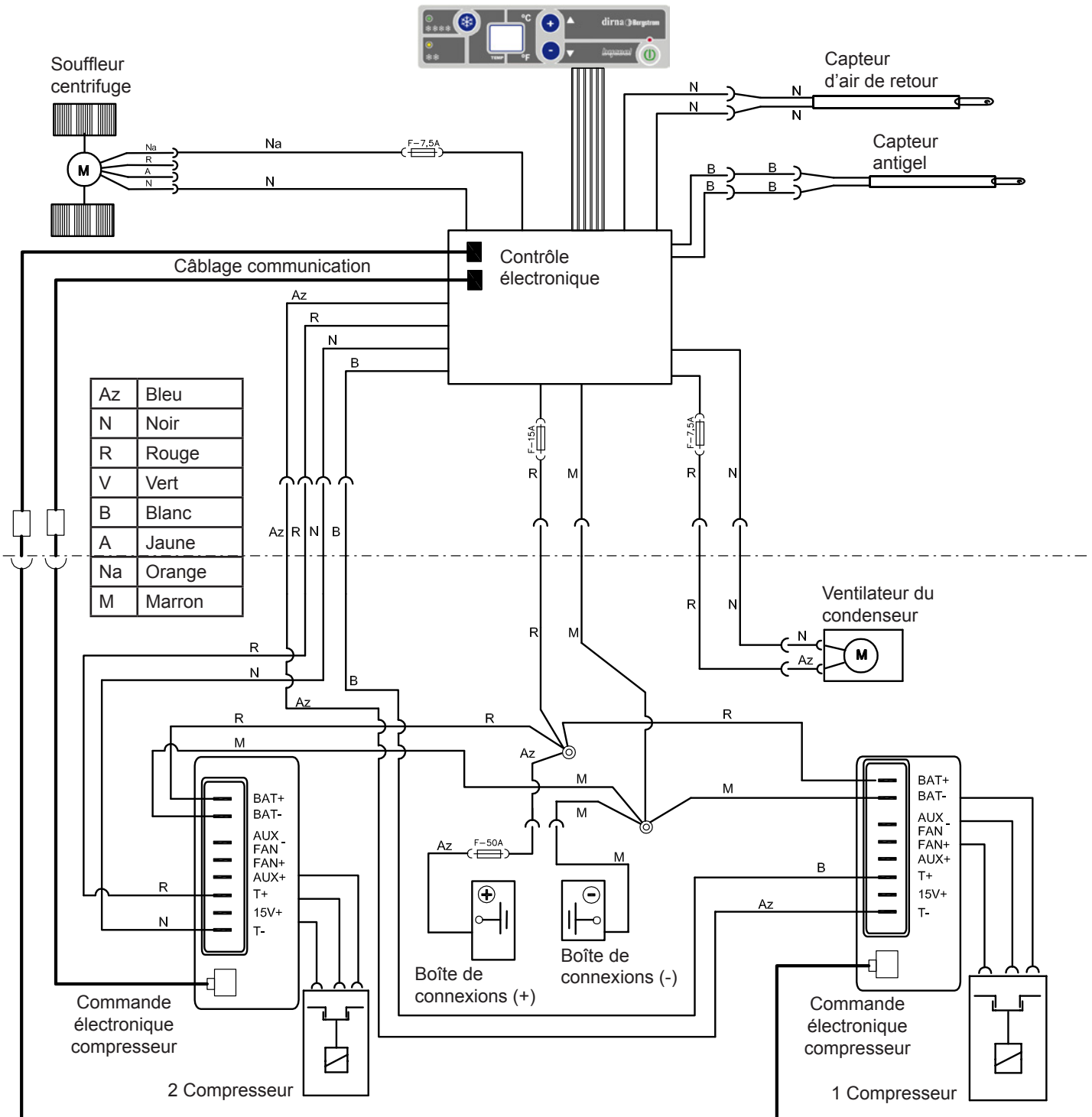

## Empfehlungen Zur montage

- Vor und während der Montage bitte diese Anweisungen lesen und beachten.
- Benutzen Sie für jeden Arbeitsschritt die geeigneten Werkzeuge.

## Elektrizität

- Zündschlüssel abziehen.
- Vor Montagebeginn die Batterie abklemmen.
- Den ordnungsgemäßen Anschluss und die korrekte Installation der Elektrokomponenten überprüfen.

## Achtung

**Sollte sich das Gerät während der Montage neigen, muss man mindestens 60 Minuten warten, nachdem es wieder in die horizontale Lage gebracht wurde, um es wieder einzuschalten.**

## Achtung

Wird die Klimaanlage im Kabinendach installiert, muss der obere Teil der Kabine mit einem Tuch oder einer Decke gegen eventuelle Kratzer geschützt werden. Bei der Installation der **Compact** auf dem Kabinendach muss darauf geachtet werden, dass mit Luken ausgestattete Kabinen über eine ausreichend stabile Struktur verfügen, um das Gewicht des Geräts stand zu halten. Sollte das Fahrzeug über keine Luke verfügen und sollte es notwendig sein, das Kabinendach aufzuschneiden, bzw. sollte die vorhandene Struktur nicht ausreichend stabil sein (z.B. wenn sie aus Faser, Kunststoff usw. hergestellt ist), obliegt es dem Installateur zu entscheiden, ob das Kabinendach zur Vermeidung von Verformungen, Brüchen, undichten Stellen usw. verstärkt werden muss, und die hierfür notwendigen Mittel bereit zu stellen.



## Werkzeuge

- Torx-Schraubenschlüssel
- Inbusschraubenschlüssel
- 10er, 13er, 14er Schraubenschlüssel
- Schere
- Metermaß







## Mitgelieferte unterlagen

Montageanweisungen	220.AA2.7002
Benutzerleitfaden	220.AA6.0057
Fehlerdiagnose	220.AA6.0058
Garantie	220.AA1.0017

## Symbologie

-  Fragile
-  Attention aux coupures !
-  Risque électrique

## Warnhinweise

-  Der Installateur muss im Bereich Fahrzeug-Klimaanlagen ausreichend geschult sein.
-  **dirna Bergstrom, s.l.** übernimmt keine Verantwortung für Schäden oder Brüche aufgrund einer nicht ordnungsgemäßen Installation oder Bedienung des Geräts oder den Austausch von Teilen bzw. Umbauten, die ohne die erforderliche schriftliche Genehmigung durchgeführt wurden.
-  **Mit Kältemittel vorgefülltes Gerät, R-134a. (Kältemittelkreislauf nicht manipulieren).**
-  Siehe **Garantieverfahren** des Produkts in der **Fehlerdiagnose**.
-  Siehe **Benutzerleitfaden** des Geräts für den ordnungsgemäßen Betrieb der Fernbedienung und des Bedienfelds.
-  Die folgenden Unterlagen müssen dem Benutzer nach der Installation ausgehändigt werden: **Benutzerleitfaden, Garantie und Fehlerdiagnose.**



 Vor Montabeginn vorderes Lufteintrittsgitter montieren.



**1** Lukendeckel und Befestigungselemente ausbauen und beiseite legen.  
 (\*) innerer Rahmen.



**2** Vor dem Ankleben der EPDM-Dichtung die Klebstoffreste von der oberen Kabinenfläche entfernen.

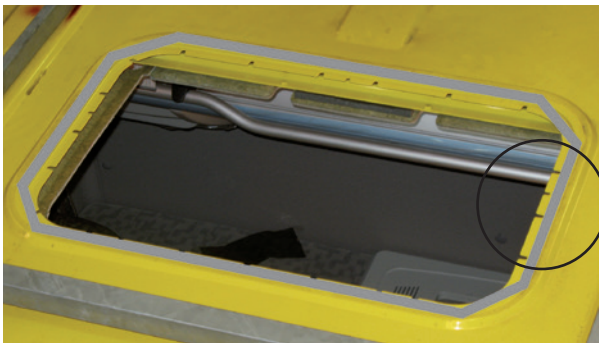

**3** Die EPDM-Dichtung um die Lukenöffnung herum ankleben (siehe Detailansicht für das Schneiden der Ränder).

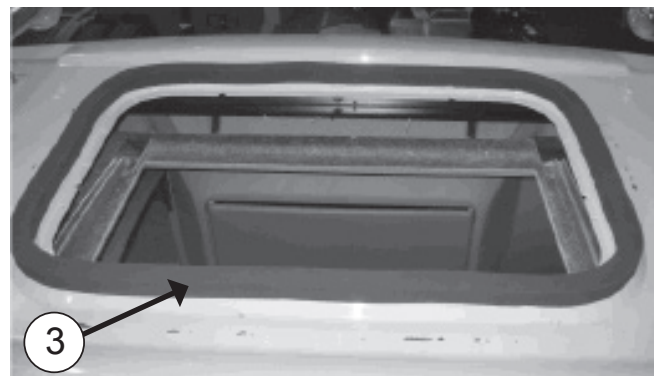

 **WIE DIE EPDM-DICHTUNG GESCHNITTEN WIRD, UM WASSERUNDICHTIGKEITEN IN DIE KABINE ZU VERMEIDEN**

**A-** Dichtung aufkleben und dabei einen Papierschutz von 100 mm auf jeder Seite beibehalten.

**B-** Die zwei Papierstücke entfernen.

**C-** Unter Anpressen beider Enden aufkleben.

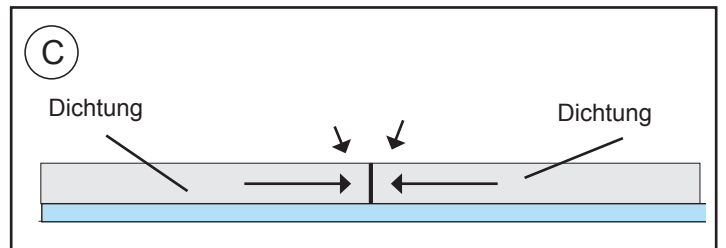
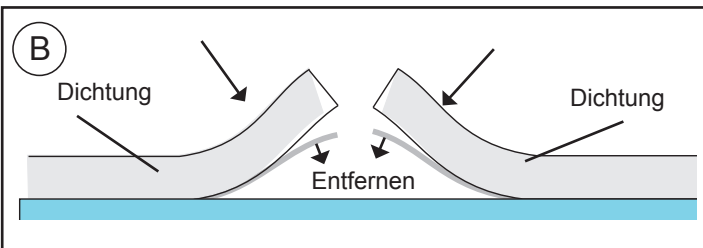
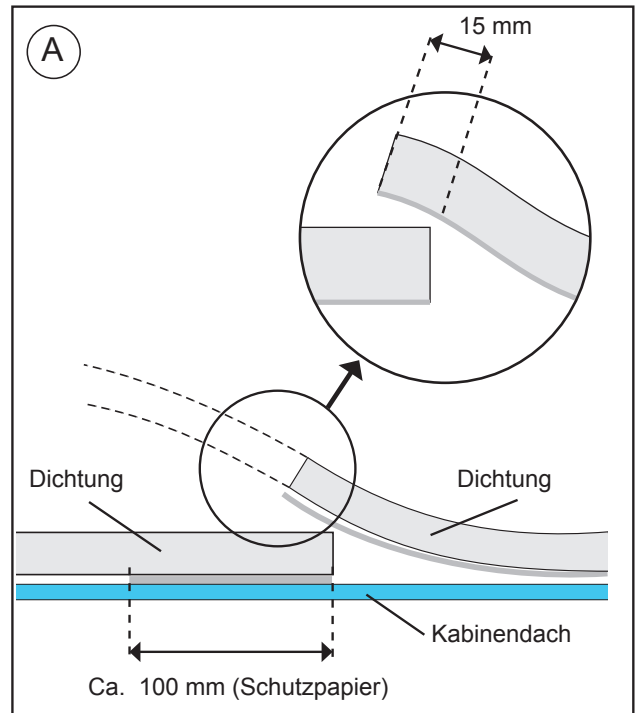

**4** **KABINENAUSSENSEITE:**  
 Compact in der Öffnung positionieren.  
**Achtung!** Beim Auflegen des Geräts auf die Lukenaussparung darauf achten, dass die Ablassausgänge nicht von der EPDM-Dichtung zusammengedrückt werden.

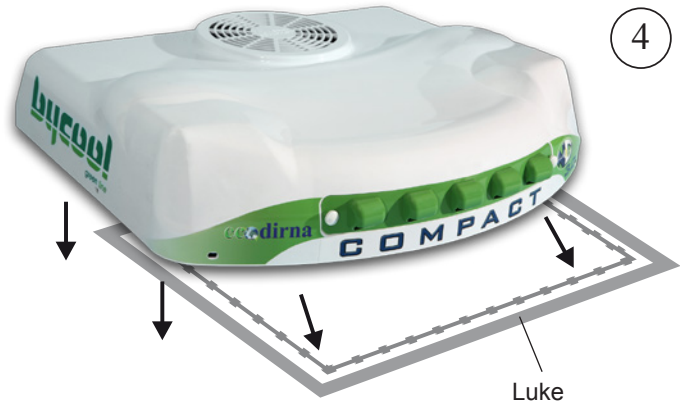

**5** Montieren Sie den Schaumgummi Luftkanal mit dem weichen Teil zur Grundplatte / Basis.

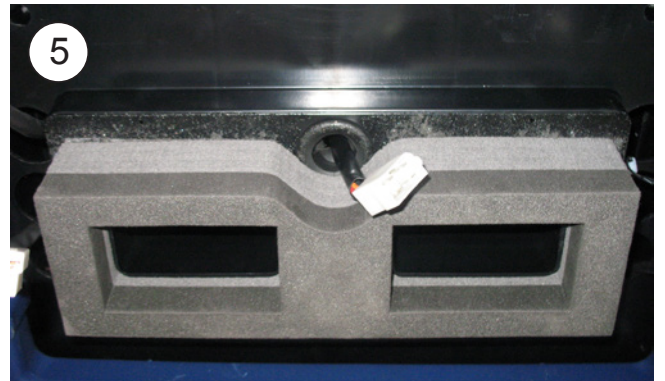

**6** **KABINENINNENSEITE:**  
 Ca. 5 mm Gewinde für (4) Stiftschrauben 8/125x100 oder 120 mm schneiden (abhängig vom größeren oder kleineren Abstand vom Gerät bis sie nach Positionierung der Befestigungsauflagen 20 mm unter diesen liegen).

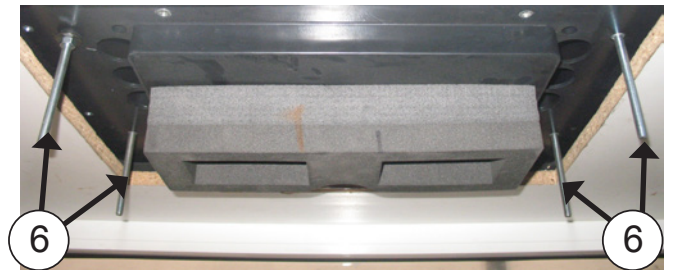
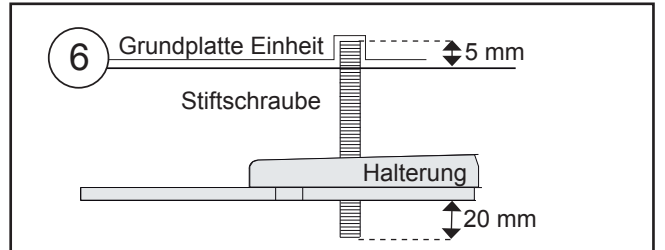

**7** Montieren Sie wie folgt:  
 Gummischeibe / 3D Unterlegscheibe / Mutter / Gewindestange.

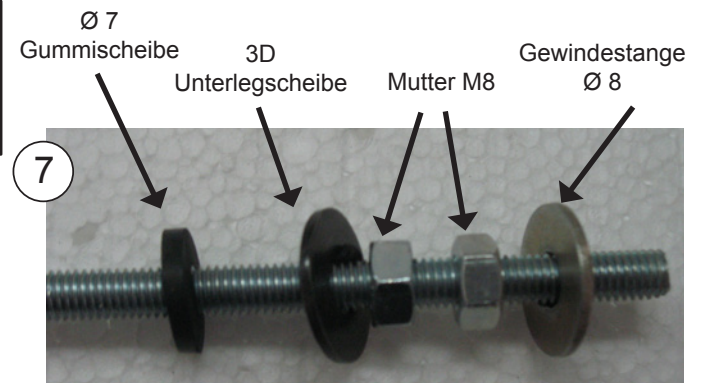



**8** Befestigungsauflagen (2) mit einer Unterlegscheibe (1) und einer Autobloc-Mutter (1) M8 einlegen, **jedoch ohne anzuziehen**.

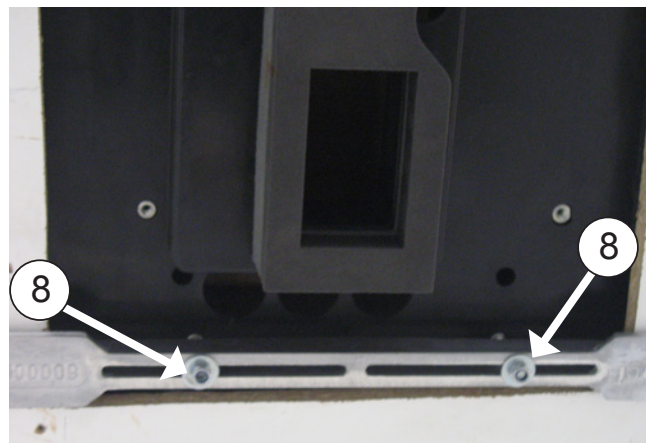
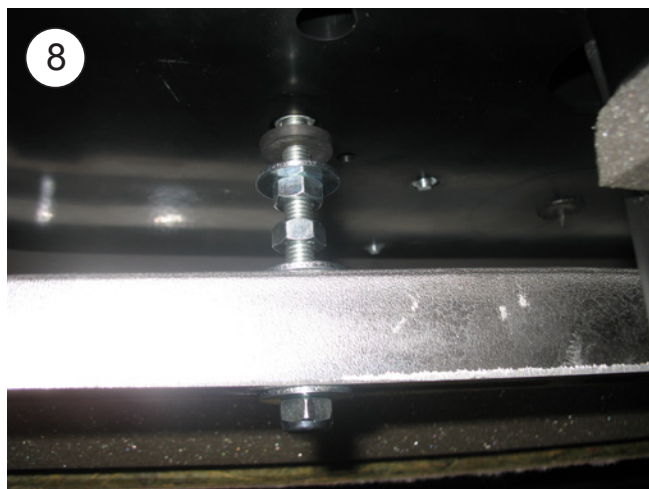

**9** 10 mm Gewinde für die Stiftschrauben (4) M6 x 55-80 am angegebenen Punkt schneiden laut Distanz (D) beschrieben in Abbildung 11.

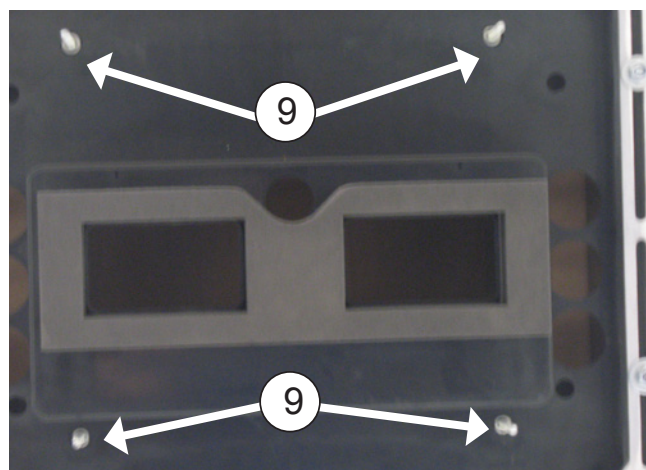
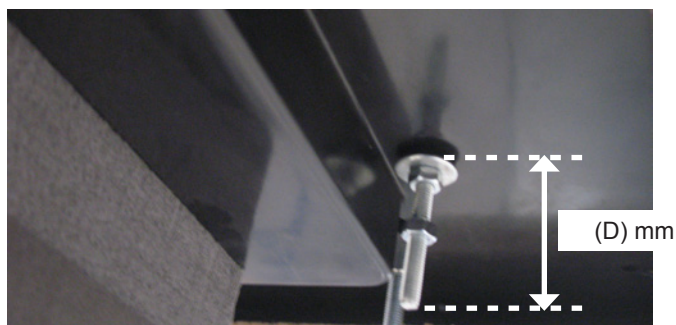

**10** Montiere (1) Gummi-Unterlegscheibe, (1) 3D Unterlegscheibe (1) Mutter auf jede Gewindestange. Später ziehen Sie die Mutter an, bis die Gummischeibe ein wenig zusammengepresst ist.

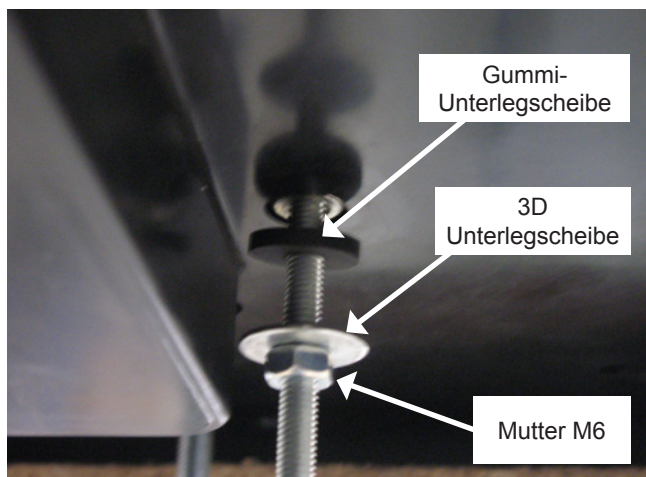

**10a**

Jeweils die Mutter (1) M6 ohne Anziehen auf die Stiftschrauben legen.

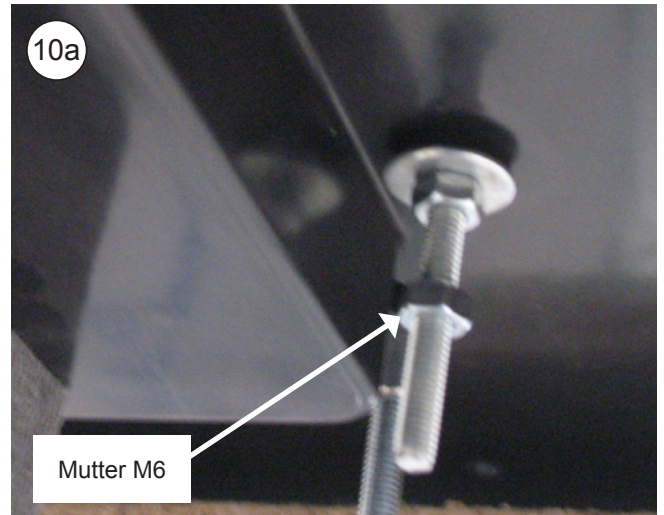

Mutter M6

**10b**

(2) Kommunikationskabel (A), (2) 4-Wege-Kästen und (4) 2-Wege-Kästen der inneren Luftverteiltertafel mit denen des **Compact** verbinden.

Dabei beachten, dass der mit den weißen Kabeln markierte Zwei-Wege-Kasten an dem im mittleren Bereich des Geräts mit den weißen Kabeln heraustretenden Stecker anzuschließen ist.

**ACHTUNG: Die Farben des 2-Wege-Kastens des Elektrolüfters dürfen (Kasten mit Kabeln R und N) keinesfalls vertauscht werden!**

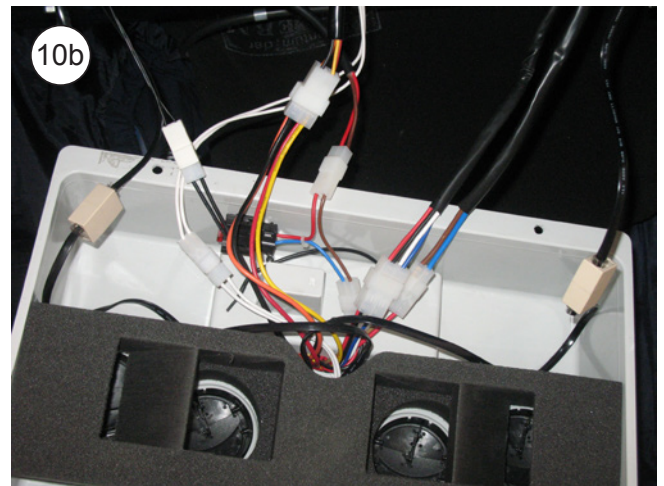

**10c**

Kabel in die Aussparung (H) in der inneren Luftverteiltertafel stecken, um die Justierung der Kabelführungen mit der Grundplatte der Anlage nicht zu beeinträchtigen.

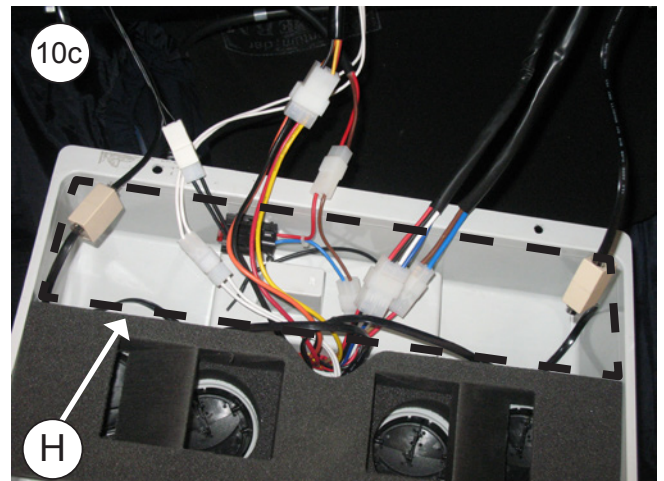

H

11

Innere Luftverteiltertafel an den vorgenannten Stiftschrauben mit jeweils (1) Breitflansch-Unterlegscheibe M6 und (1) Mutter M6 anbringen. Muttern anziehen, bis die Schaumstoffführung am oberen Schaumstoff der Anlage anliegt.

**Wichtig: Der Schaumstoff und die Luftkanalisierung müssen sich berühren, um Falschlucht zu verhindern.**

11

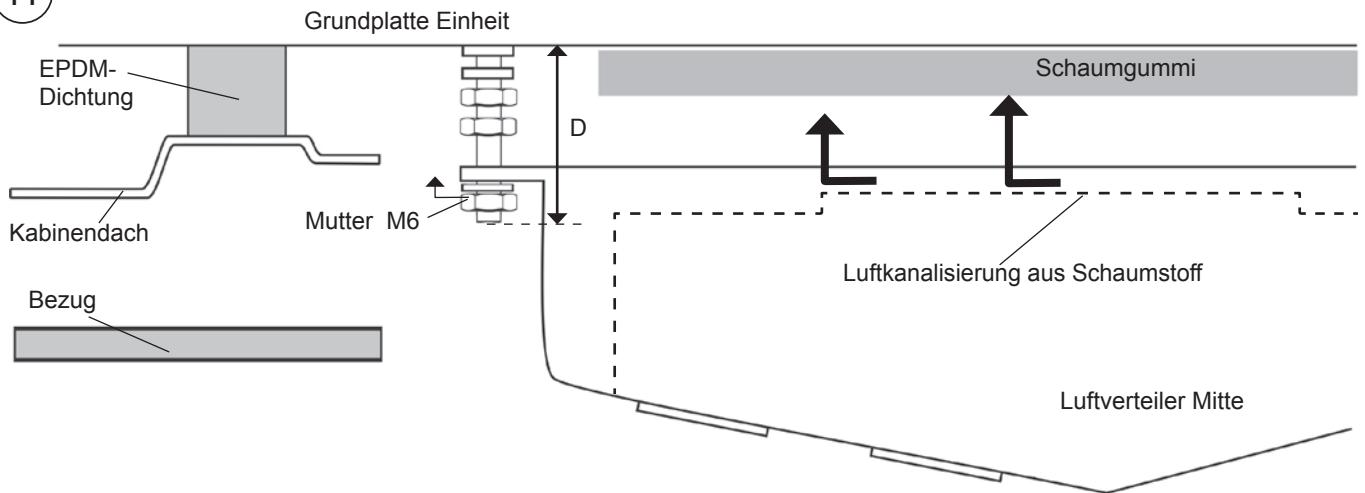

12

Mutter aus Punkt 10a anziehen, bis diese an das Oberteil der inneren Luftverteiltertafel stößt.

12

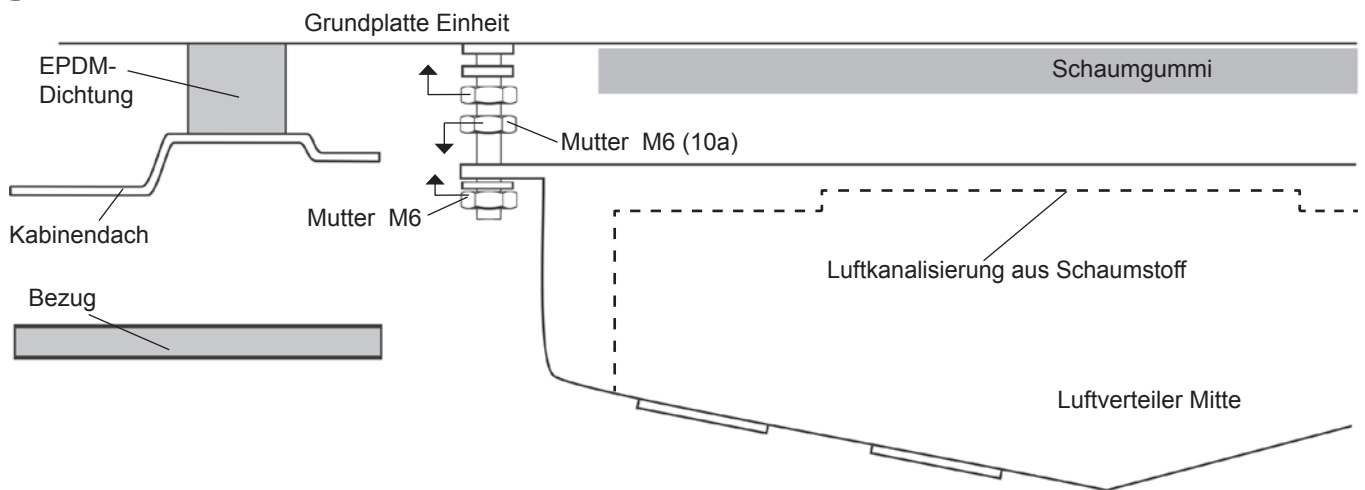



**13** Originalkonsole in zwei Teile trennen. Zuerst müssen die zwei Schrauben hinten ausmontiert sein.

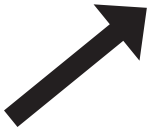

**14** Konsolenrahmen A mit den Originalschrauben in seiner Originalposition einbauen.

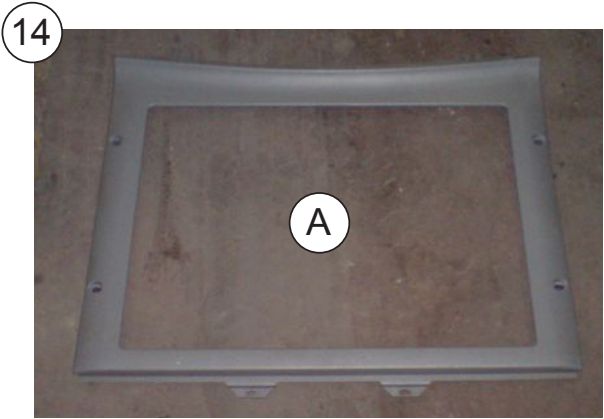

**15** Mitgelieferte Konsole auf den Originalkonsolenrahmen legen und Gerät zentrieren.

**ACHTUNG! DIE VORHANDENE ÖFFNUNG ZWISCHEN RAHMEN UND FRONT MUSS GESCHLOSSEN WERDEN.**



**16** Die Halterungen durch Anziehen der Muttern befestigen, bis die EPDM-Dichtung des Geräts zwischen 3 und 6 mm komprimiert wird.

**Wichtiger Hinweis:** Um das Eindringen von Wasser in die Kabine zu verhindern, die die Verbindung der EPDM-Dichtung mit der Grundplatte des Compact wie in Schema gezeigt überprüfen.

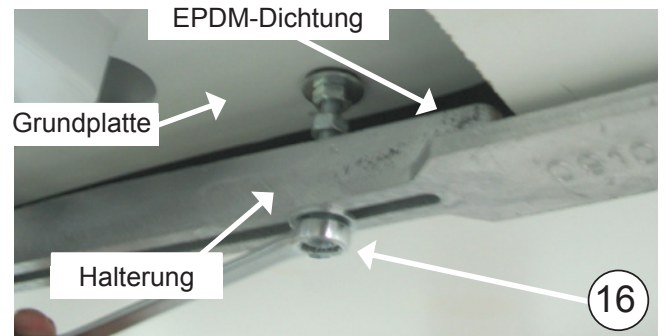
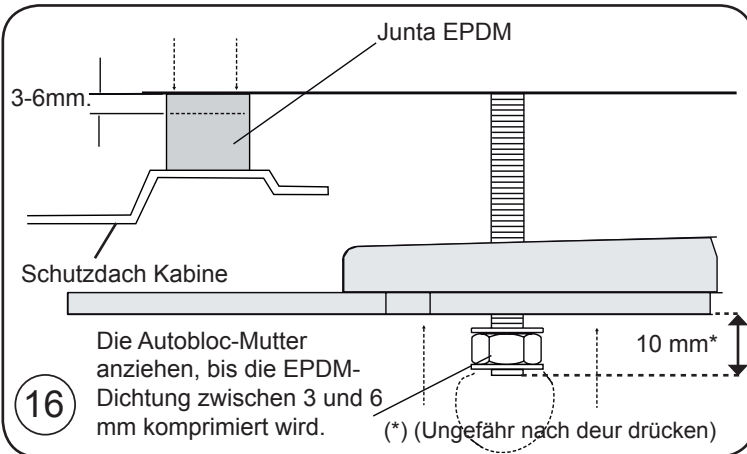

**17** Die Muttern (4) M8 anziehen, um sie an der Grundplatte zu befestigen.

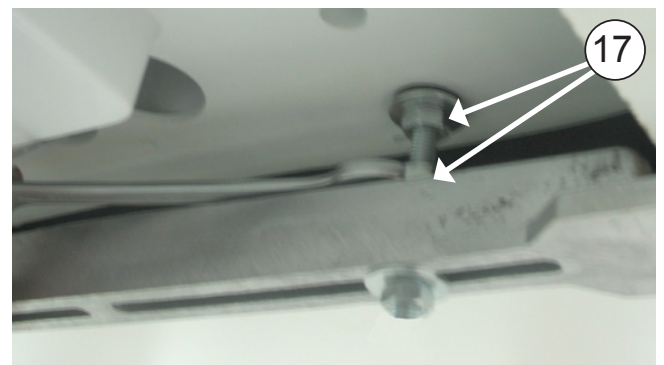

**18**

Konsole auf Originalkonsolenrahmen mit (8) Blechschrauben 3,5x16 und den zuvor gebohrten (8) Löchern Ø 3 befestigen.

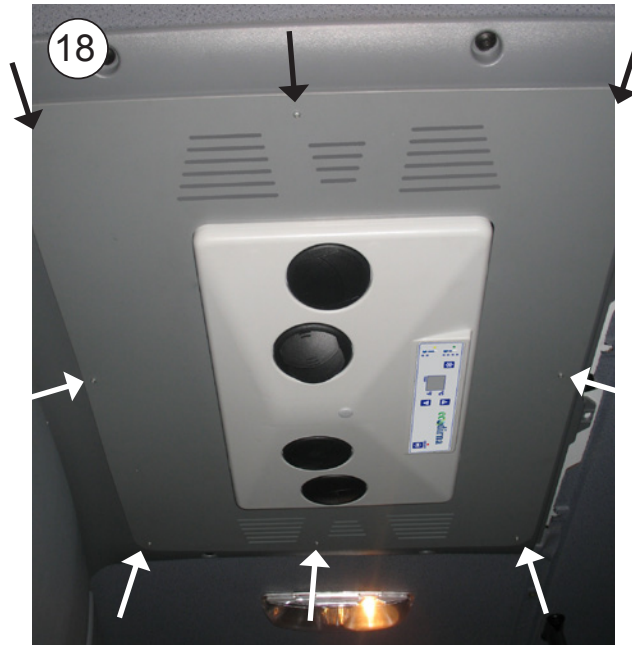



**Explosionsansicht bis zur befestigung der befestigungsauflagen**

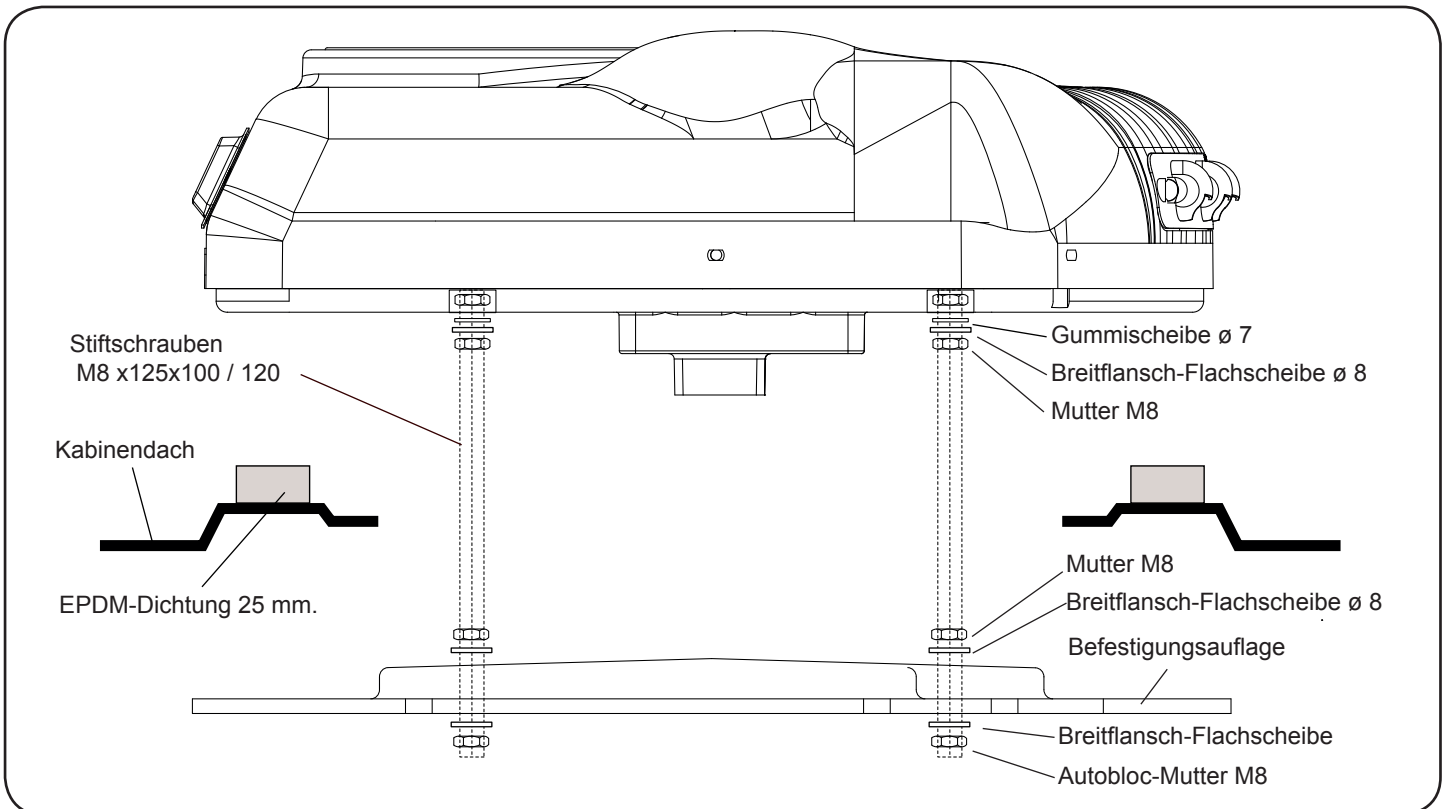

**Explosionsansicht bis zur befestigung der konsolen**

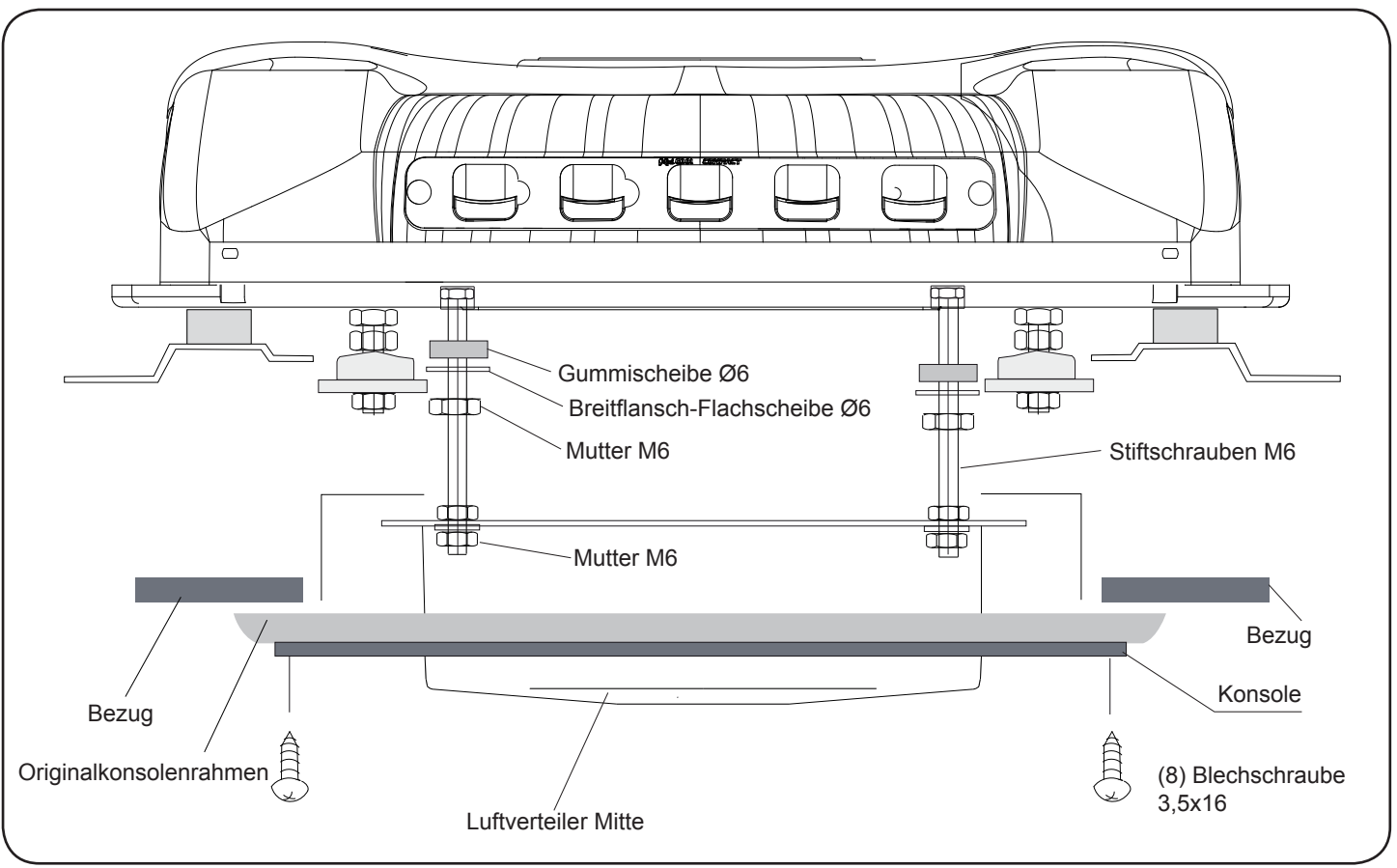

## Detaillierte Hinweise für die Installation der Netzkabel

**1**

Das Netzkabel an der Gerätehinterrseite anschließen und an der Kabinenrückseite unter Ankleben der Kunststoffhalterungen und Befestigung durch Kabelbinder entlang führen.

**2**

Unteres Netzkabel an obere Netzkabelklemme anschließen.



## Anschluss an die hinteren Batterien

**3** Positivkabel (blau) zur Position X3 des Anschlusskastens führen. Überschüssiges Kabel abschneiden, mitgelieferte Klemme Ø 6 anbringen und zusammen mit dem Sicherungsstück anschließen. Kabel in Position X3 mit Unterlegscheibe und selbstsichernder Mutter befestigen.

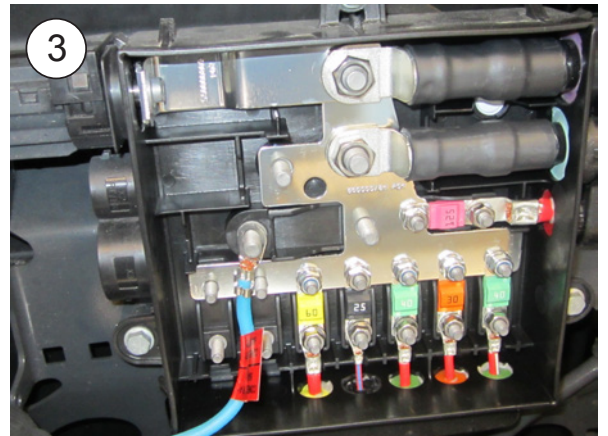
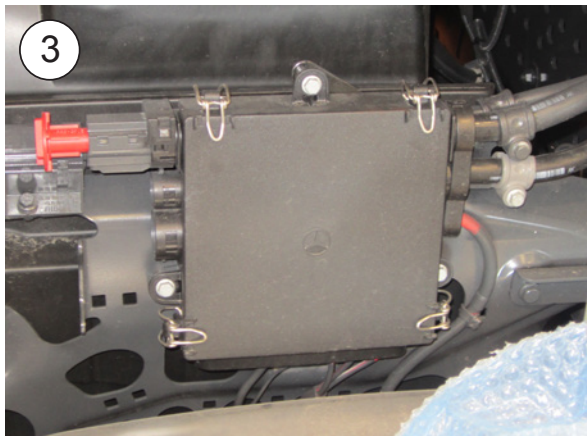
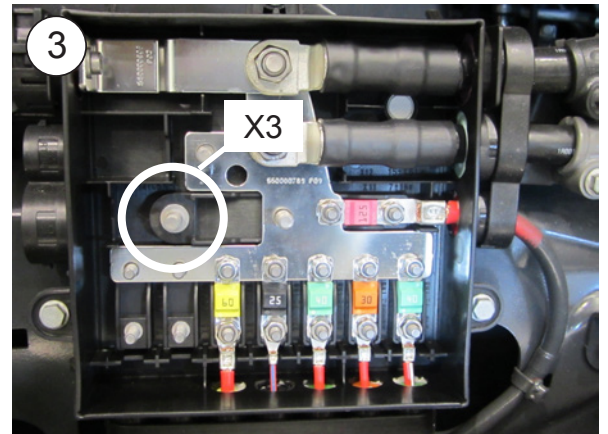

**4** Negativkabel (braun) zum negativen Anschlusskasten in Batterienähe führen. Kabel mit Unterlegscheibe und selbstsichernder Mutter befestigen.





## Vordere Batterien

3

Positivkabel (blau) zur Position X3 im Anschlusskasten (in Batterienähe) führen. Überschüssiges Kabel abschneiden, mitgelieferte Klemme Ø 6 anbringen und zusammen mit dem mitgelieferten Sicherungsstück anschließen. Kabel in Position X3 mit Unterlegscheibe und selbstsichernder Mutter befestigen.

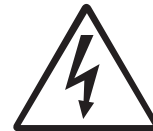
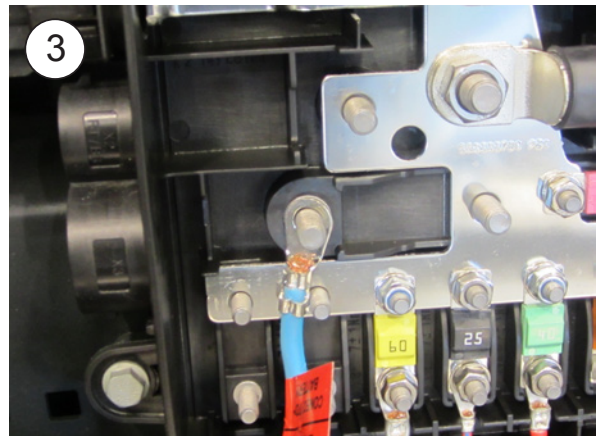

4

Negativkabel (braun) zum negativen Anschlusskasten neben der Negativklemme der Batterie führen. Überschüssiges Kabel abschneiden, Klemme Ø 10 anbringen und mit Unterlegscheibe und selbstsichernder Mutter befestigen.

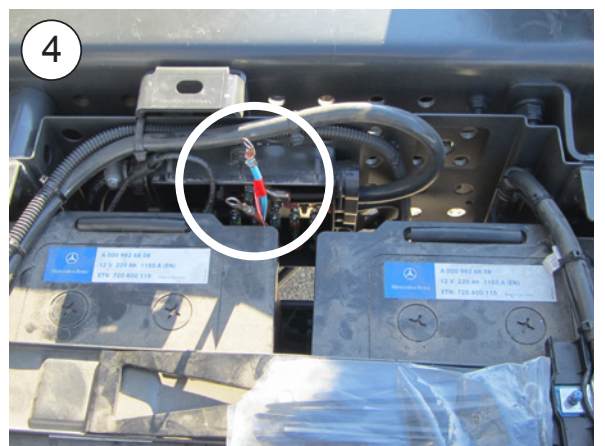

## Direkter Anschluss an die Batterien

- 3** Positives und negatives Kabel über die Originalkabelführung zur Batterie führen und dabei mit Kabelbindern befestigen.

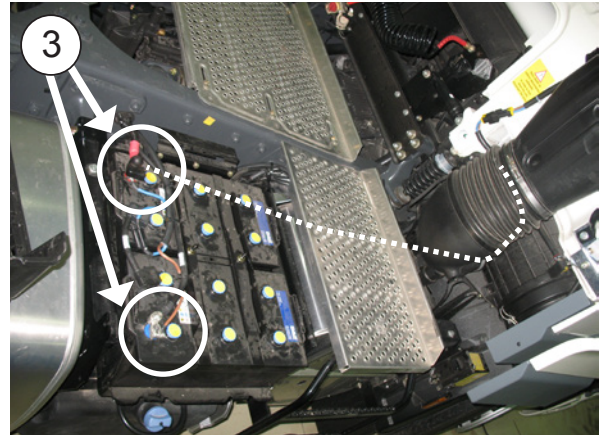

- 4** Überschüssiges Kabel abschneiden, mitgelieferte Kabelschuhe befestigen und anschließen.

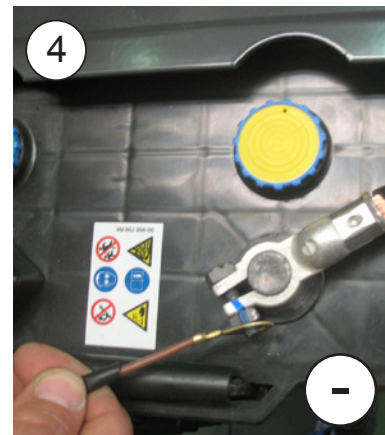
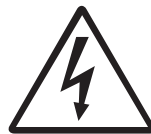

**ACHTUNG:** Beim Anschluss der Kabel zur Vermeidung von Schäden durch die Kabinenbewegungen ausreichend Spielraum lassen.

**WICHTIGER HINWEIS:** Für die Inbetriebnahme sehen Sie bitte im Benutzerhandbuch nach.

- 5** Gefahrenhinweise an Kabelverbindung und Kabinenhebevorrichtung anbringen.



# Elektrische Verkabelung

## WICHTIGER WARHNHWEIS!

**Darauf achten**, dass die Polaritäten beim Anschluss der Stromversorgung an das Gerät nicht vertauscht werden. Ist dies der Fall, schaltet sich die Elektroniktafel nicht ein, das Gerät funktioniert nicht und es kommt zu irreparablen Schäden an den Kompressormodulen.

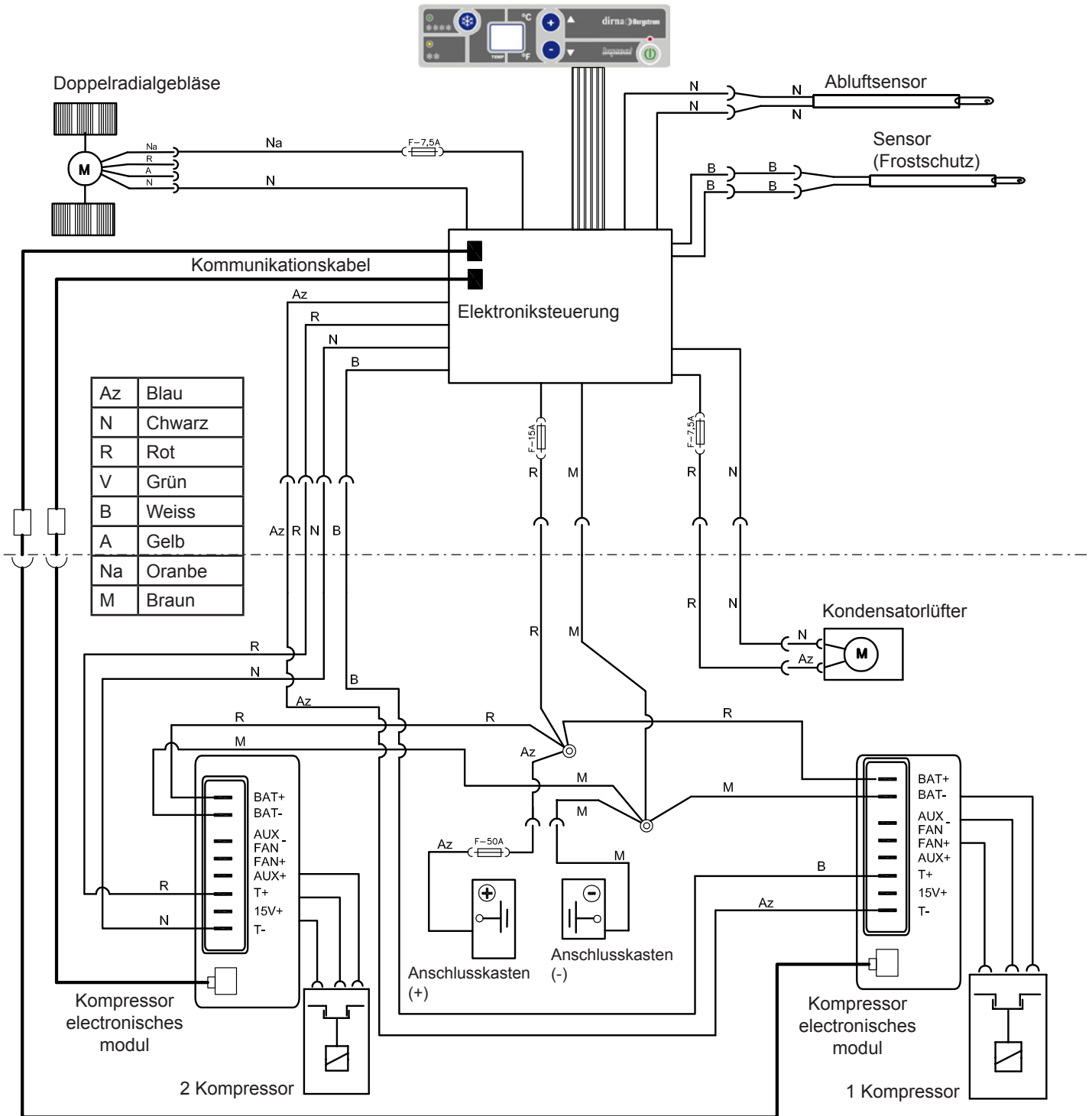



## Suggerimenti per il montaggio

- Prima di cominciare il montaggio, leggere attentamente le istruzioni e rispettarle nel corso dello stesso.
- Usare gli attrezzi più adatti ad ogni operazione.

## Elettricità

- Scollegare la chiave di contatto.
- Scollegare la batteria prima di cominciare il montaggio.
- Assicurarsi di avere effettuato correttamente l'installazione e il collegamento dei componenti elettrici.

### Attenzione

Se durante il montaggio si inclina l'impianto, prima di rimetterlo in funzione occorre attendere almeno 60 minuti dal momento in cui è di nuovo in posizione orizzontale.

### Attenzione

Quando si installa l'impianto di aria condizionata sul tettuccio, bisogna proteggere la parte superiore della cabina con uno straccio o una coperta per evitare eventuali graffi. Per l'installazione del **Compact**, tenere presente che normalmente le cabine munite di oblò dispongono di una struttura abbastanza solida per sostenere il peso dell'impianto. Tuttavia, se così non fosse e se fosse necessario tagliare il tettuccio, o se in presenza di oblò la struttura non fosse abbastanza rigida (se fosse di fibra, plastica, ecc.), è responsabilità dell'installatore decidere se occorre rinforzare il tettuccio per evitare qualsiasi deformazione, rottura o penetrazione d'acqua, ecc., prendendo le misure necessarie per evitarlo.

## Attrezzi

- Kit di chiavi Torx
- Kit di chiavi Allen
- Chiave fissa 10, 13, 14
- Forbici
- Metro a nastro

## Documentazione allegata

Istruzioni di montaggio	220.AA2.7002
Guida dell'utente	220.AA6.0057
Soluzione dei problemi	220.AA6.0058
Garanzia	220.AA1.0017

## Simbologia



Fragile









Attenzione alle mani



Tensione elettrica pericolosa

### Avvertenze

-  L'installatore deve essere in possesso della formazione necessaria in materia di aria condizionata per veicoli.
-  **dirna Bergstrom, s.l.** declina ogni responsabilità per danni o rotture derivanti dall'errata installazione o dall'errato uso dell'impianto o da sostituzioni o modifiche effettuate senza la necessaria autorizzazione per iscritto.
-  **Impianto precaricato con gas refrigerante, R-134a. (Non manomettere il circuito di gas refrigerante).**
-  Vedi la **procedura di garanzia** del prodotto in **Diagnosi dei problemi**.
-  Vedi la **Guida dell'utente** dell'impianto per il corretto funzionamento del telecomando e del pannello di controllo.
-  I seguenti documenti devono essere consegnati all'utente una volta conclusa l'installazione: **Guida dell'utente, Garanzia e Diagnosi dei problemi**.

 Prima di iniziare il montaggio, installare la griglia sull'entrata anteriore dell'aria.



**1** Smontare il coperchio dell'oblò, gli elementi di fissaggio e mettere da parte.  
 (\*) telaio interno.



**2** Eliminare i residui di adesivo dalla superficie superiore della cabina prima di incollare la guarnizione EPDM.

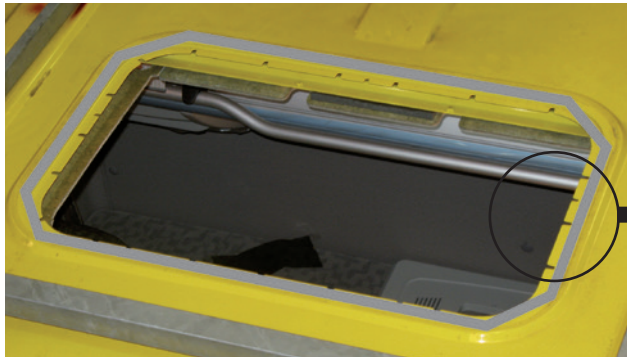

**3** Incollare la guarnizione EPDM intorno al foro dell'oblò (vedi particolare per tagliare i bordi).

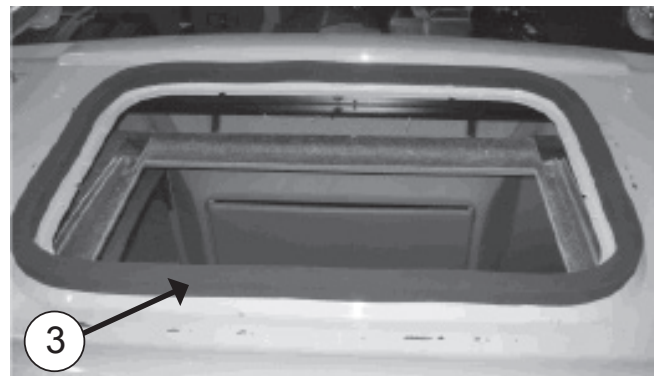

**COME TAGLIARE LA GUARNIZIONE EPDM PER EVITARE INFILTRAZIONI NELLA CABINA**

**A-** Incollare la guarnizione mantenendo una protezione di carta di 100 mm su ogni lato.

**B-** Rimuovere i due pezzi di carta.

**C-** Incollare premendo su entrambe le estremità.

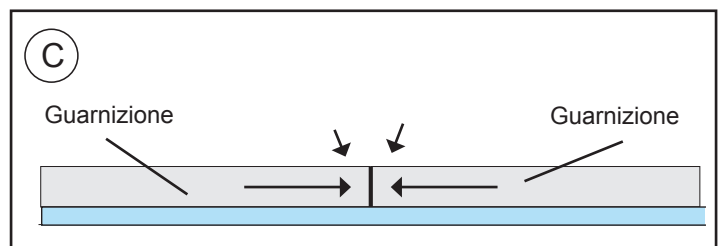
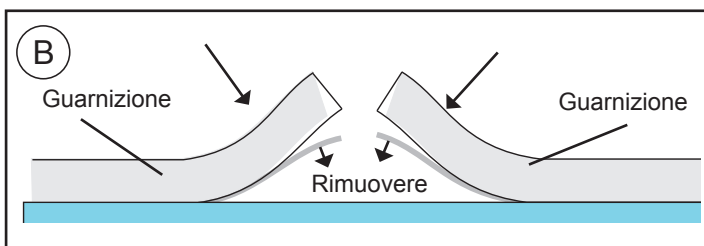
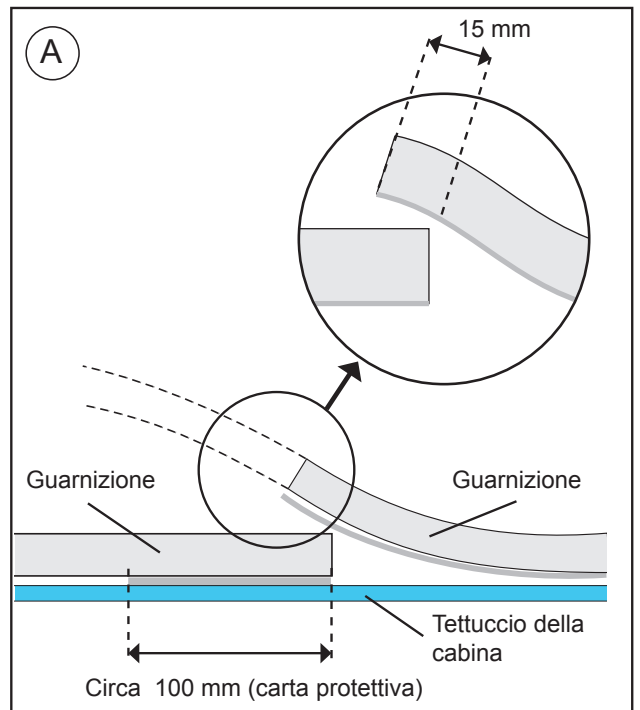



**4** **ESTERNO CABINA:**  
Inserire il **Compact** nel vano.  
**Attenzione!** Quando si posiziona l'impianto sul vano del tettuccio apribile, controllare che le uscite di scarico non siano ostruite dalla guarnizione EPDM.

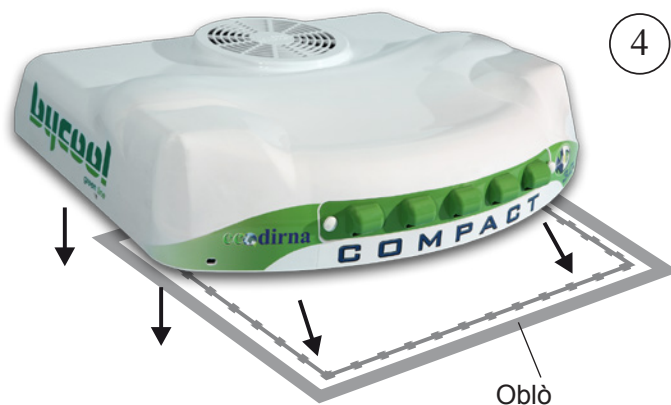

**5** Montare il canalizzatore di gommapiuma con la parte più morbida sulla base dell'impianto.



**6** **INTERNO CABINA:**  
Avvitare di circa 5 mm le (4) viti prigioniera da 8/125x100 o 120 mm, a seconda della distanza (maggiore o minore) dall'impianto finché, posizionando i supporti di fissaggio, le viti non sporgono di 20 mm dagli stessi.

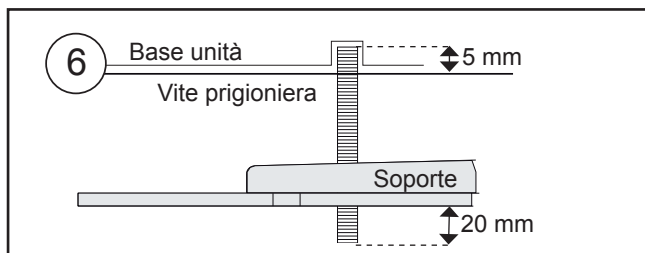

**7** Inserire (8) rondella di gomma Ø 7, (1) rondella piana Ø 1 a testa larga, (2) dadi M8 e (1) rondella piana Ø 8 a testa larga, su ciascuna vite prigioniera precedente, seguendo questo ordine.

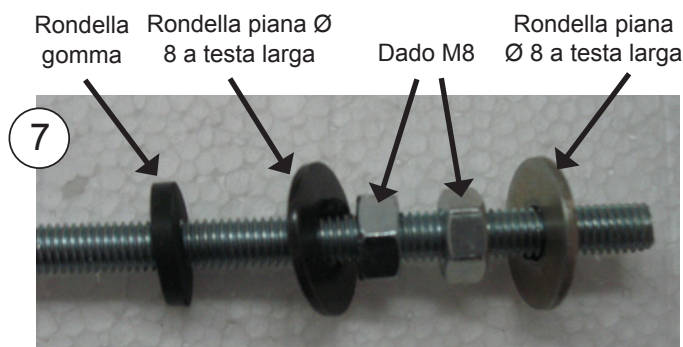

- 8** Fissare i supporti di fissaggio (2), con una rondella (1) e un dado autobloccante (1) M8, senza stringere.

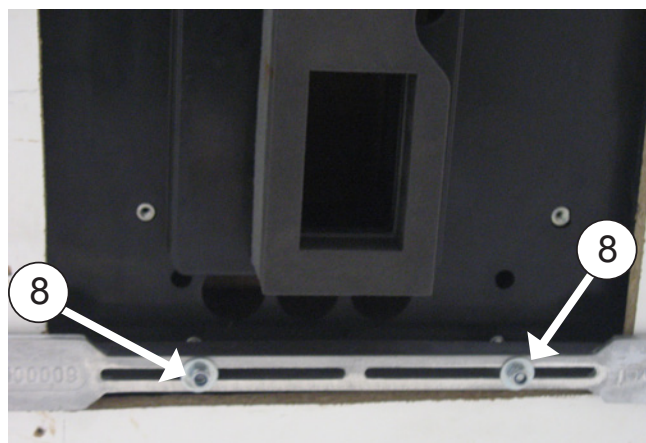
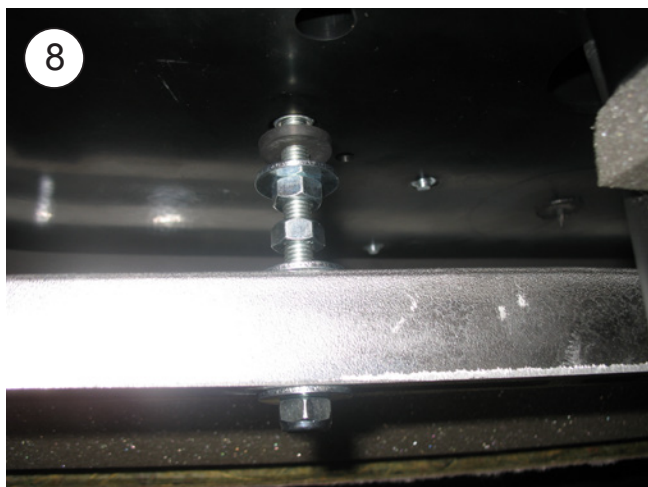

- 9** Avvitare di 10 mm i perni (4) M6 x 55 o 80, dove indicato distanza (A) segun nella a figura 16.

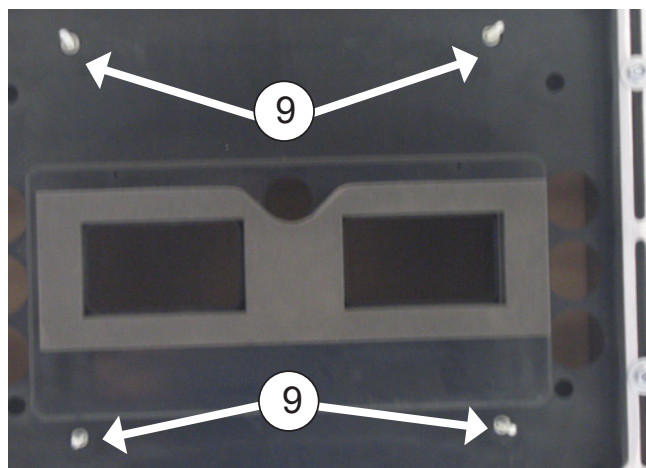
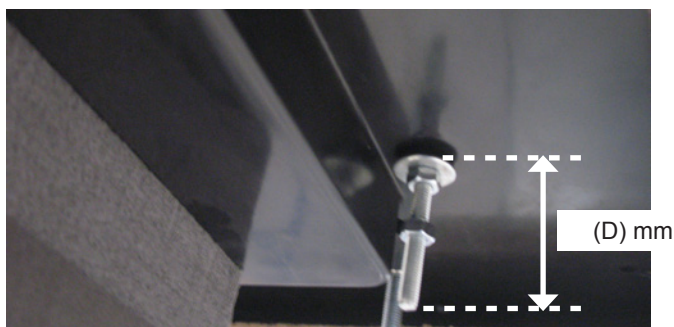

- 10** Inserire (1) rondella Ø 6 di gomma, (1) rondella piana Ø 6 a testa larga e (1) dado M6 su ogni vite prigioniera M6. Quindi stringere il dado fino a premere leggermente la rondella di gomma.

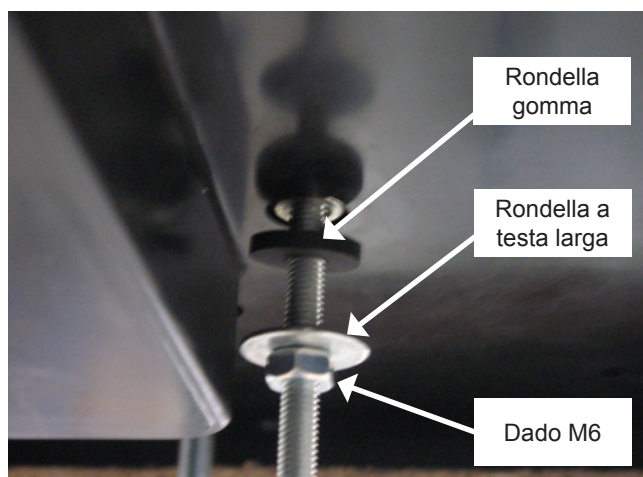



**10a**

Inserire il dado (1) M6 **senza stringere** in ogni vite prigioniera.

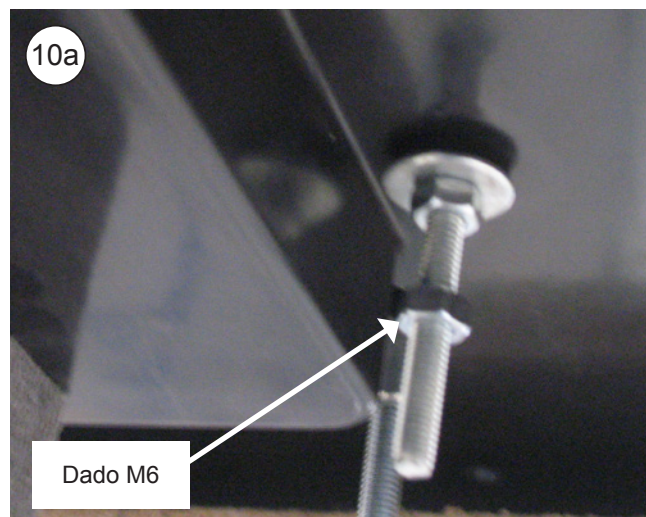
**10b**

Collegare (2) cavi per comunicazioni (A), (2) scatole a 4 vie e (4) a 2 vie del pannello interno di distribuzione dell'aria con quelle del **Compact**.

Tenere conto che la scatola a due vie contrassegnata con i cavi bianchi si collega al connettore con i cavi bianchi che esce dalla parte centrale dell'impianto.

**ATTENZIONE: È molto importante non invertire i colori della scatola a 2 vie del ventilatore del condensatore (scatola con cavi R e N).**

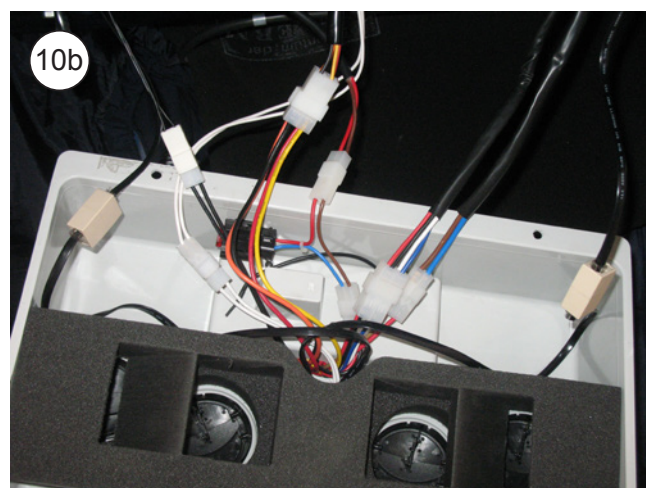
**10c**

Inserire i cablaggi nel vano (H) presente nel pannello interno di distribuzione dell'aria per non intralciare l'attacco dei canalizzatori con la base dell'impianto.

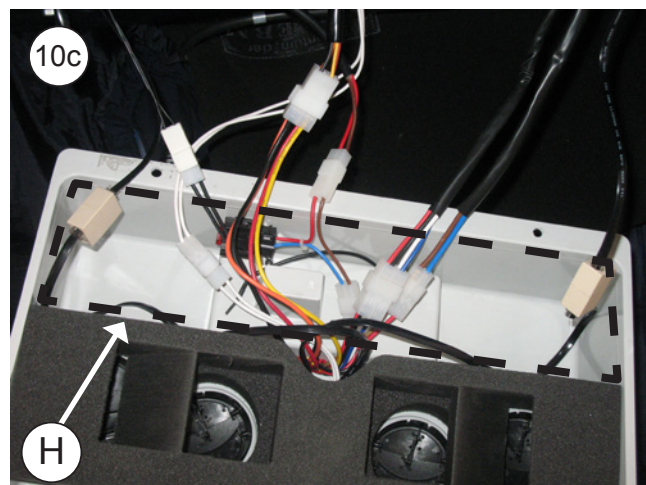



11

Montare il pannello interno di distribuzione dell'aria sulle viti prigioniera anteriori con (1) rondella M6 a testa larga e (1) dado M6 su ogni vite prigioniera. Stringere i dadi finché il canalizzatore di gommapiuma non è a battuta sulla gommapiuma superiore dell'impianto.

**Nota bene: Il canalizzatore di gommapiuma deve essere a battuta contro la gommapiuma superiore dell'impianto per evitare perdite d'aria.**

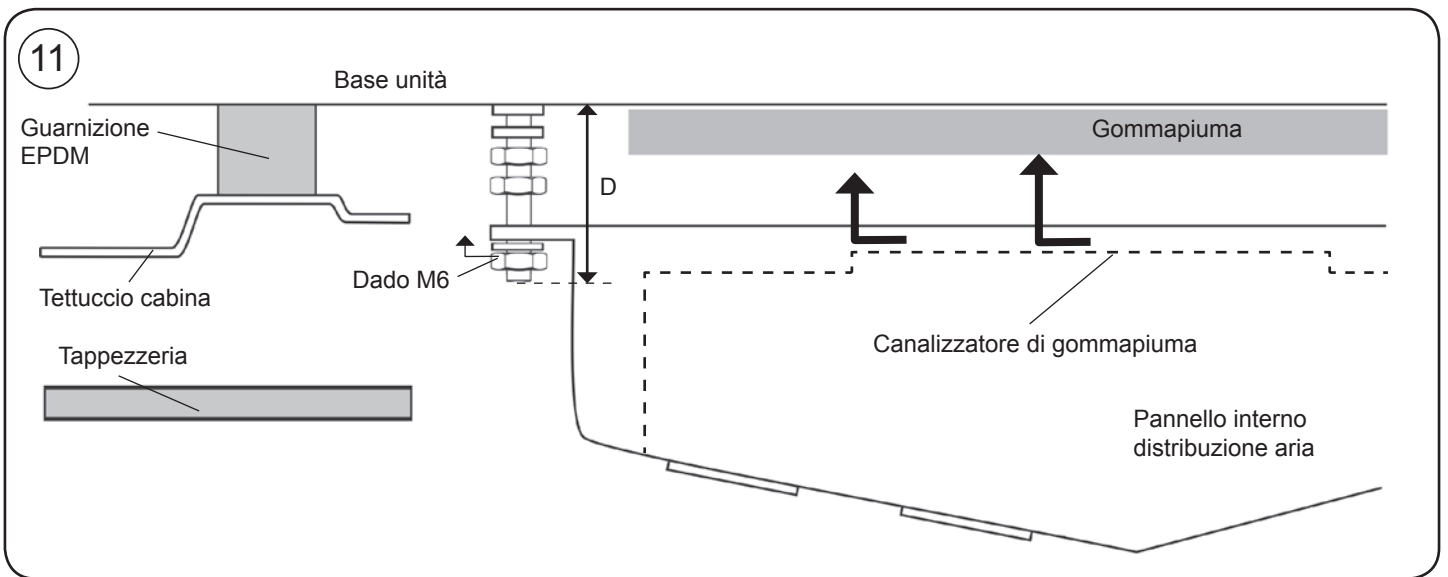

12

Stringere il dado del punto 10a fino a battuta con la parte superiore del pannello interno di distribuzione dell'aria.

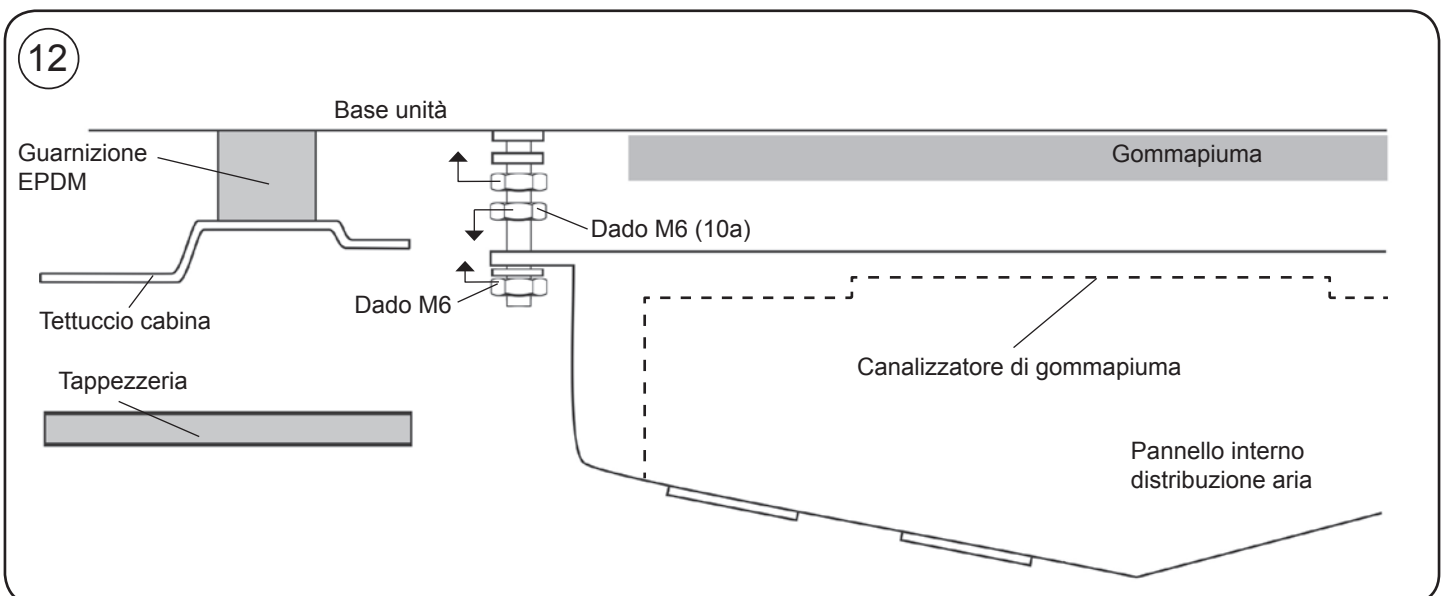

**13** Separata in due terminale originale, smontare l'unione tra le due viti poste sul retro.



**14** Montare il telaio della console **A** con le viti originali nella posizione originale.

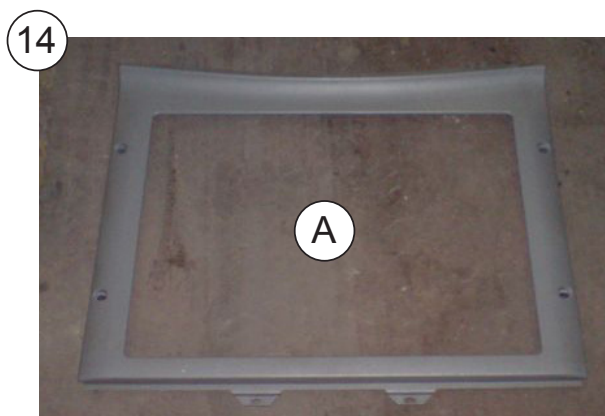

**15** Posizionare la console in dotazione sul telaio della console originale e centrare il dispositivo.

**ATTENZIONE: DEVE TAPPARE IL VANO ESISTENTE TRA IL TELAIO DELLA CONSOLE E IL FRONTALINO.**



**16** Fissare i supporti stringendo i dadi fino a comprimere, tra 3 e 6 mm, la guarnizione EPDM dell'impianto.

**Nota bene:** Per evitare che infiltrazioni d'acqua nella cabina, verificare il serraggio della guarnizione EPDM con la base Compact base, come illustrato nel Diagramma.



Controllare la compressione guarnizione in EPDM con un metro a nastro nei quattro angoli.

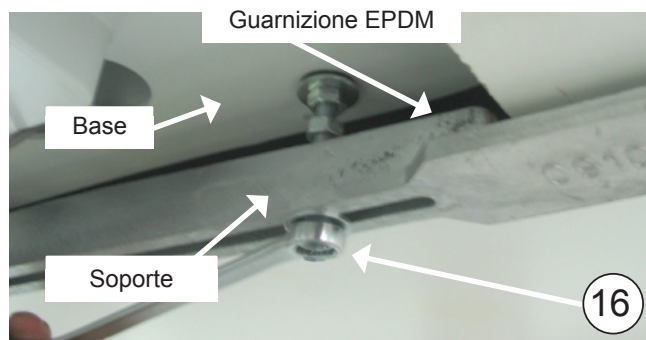
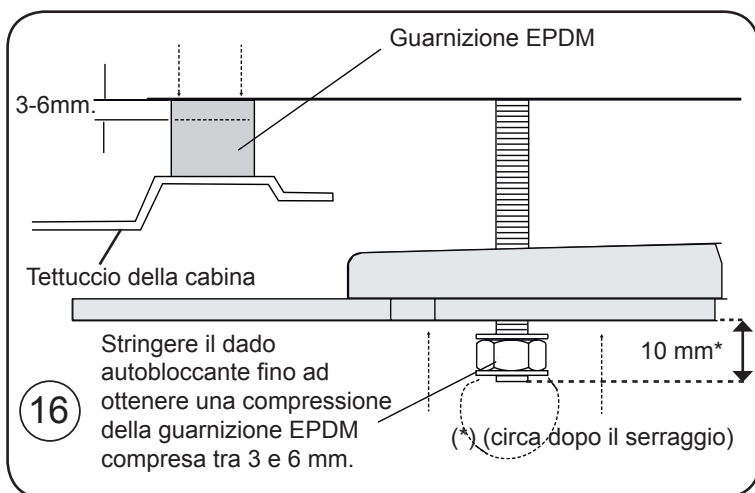

**17** Stringere i dadi (4) M8 per fissare a (4) l'unità base.

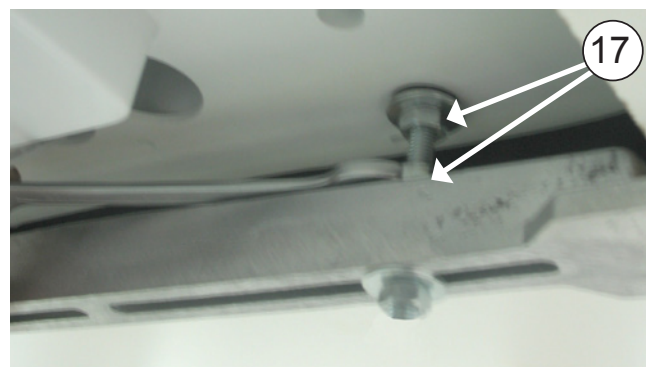



**18**

Fissare la console sul telaio della console originale con (8) viti per lamiera 3,5x16, dopo aver praticato (8) fori Ø 3.

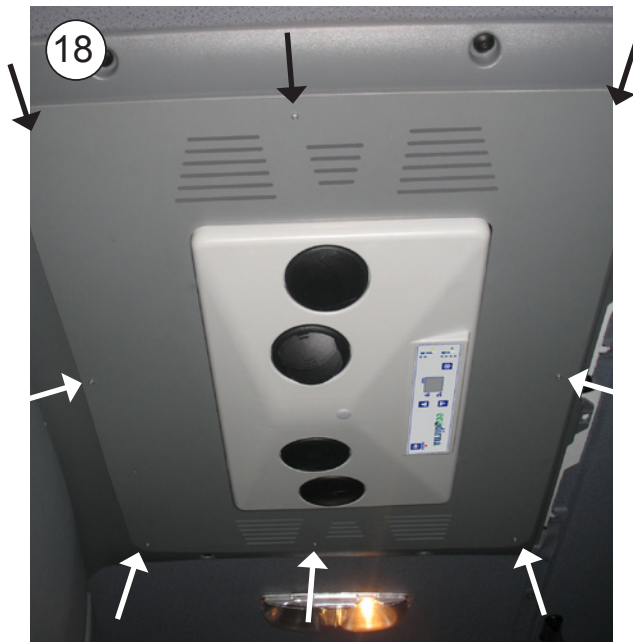

### Esplso fino al fissaggio dei supporti di fissaggio

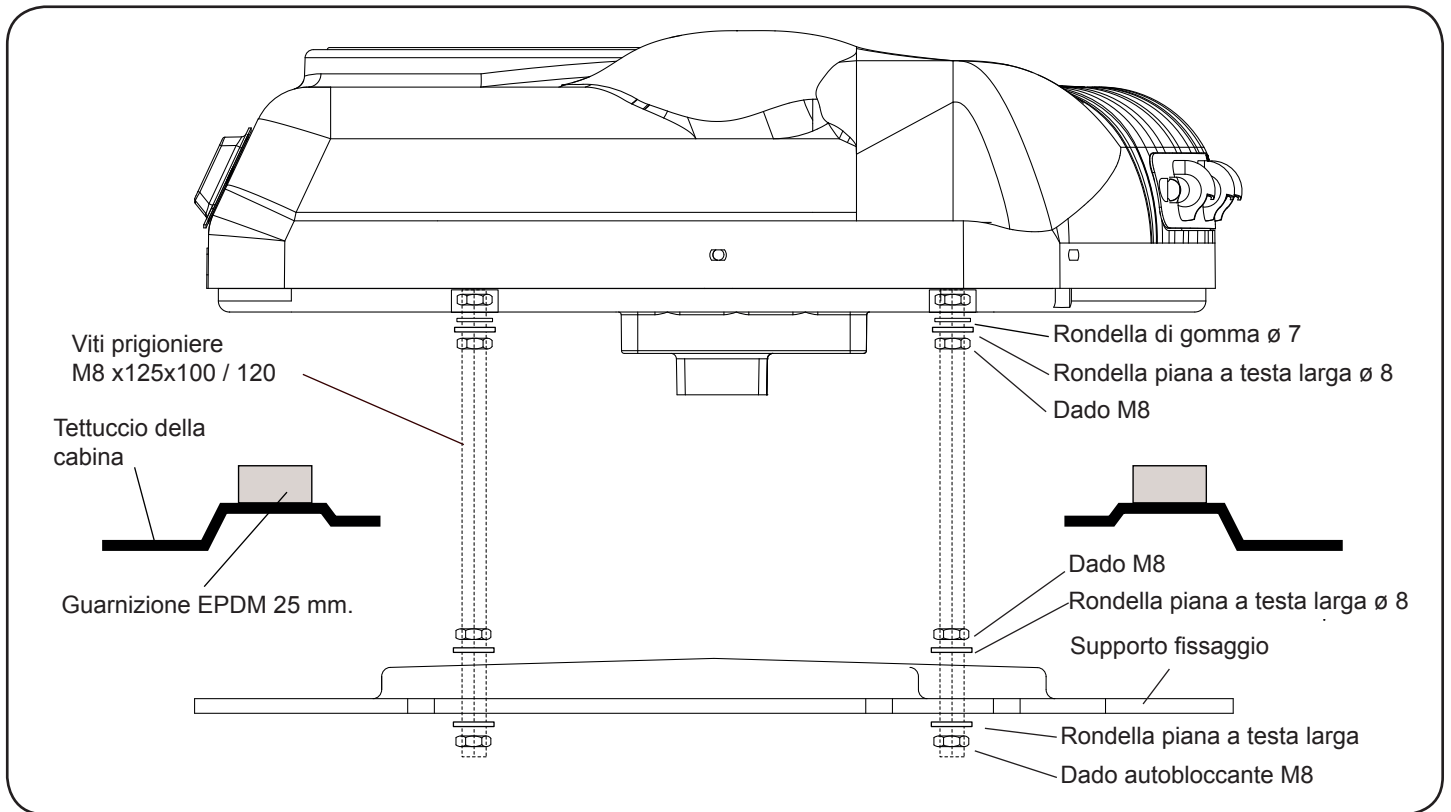

### Esplso fino al fissaggio della consolle

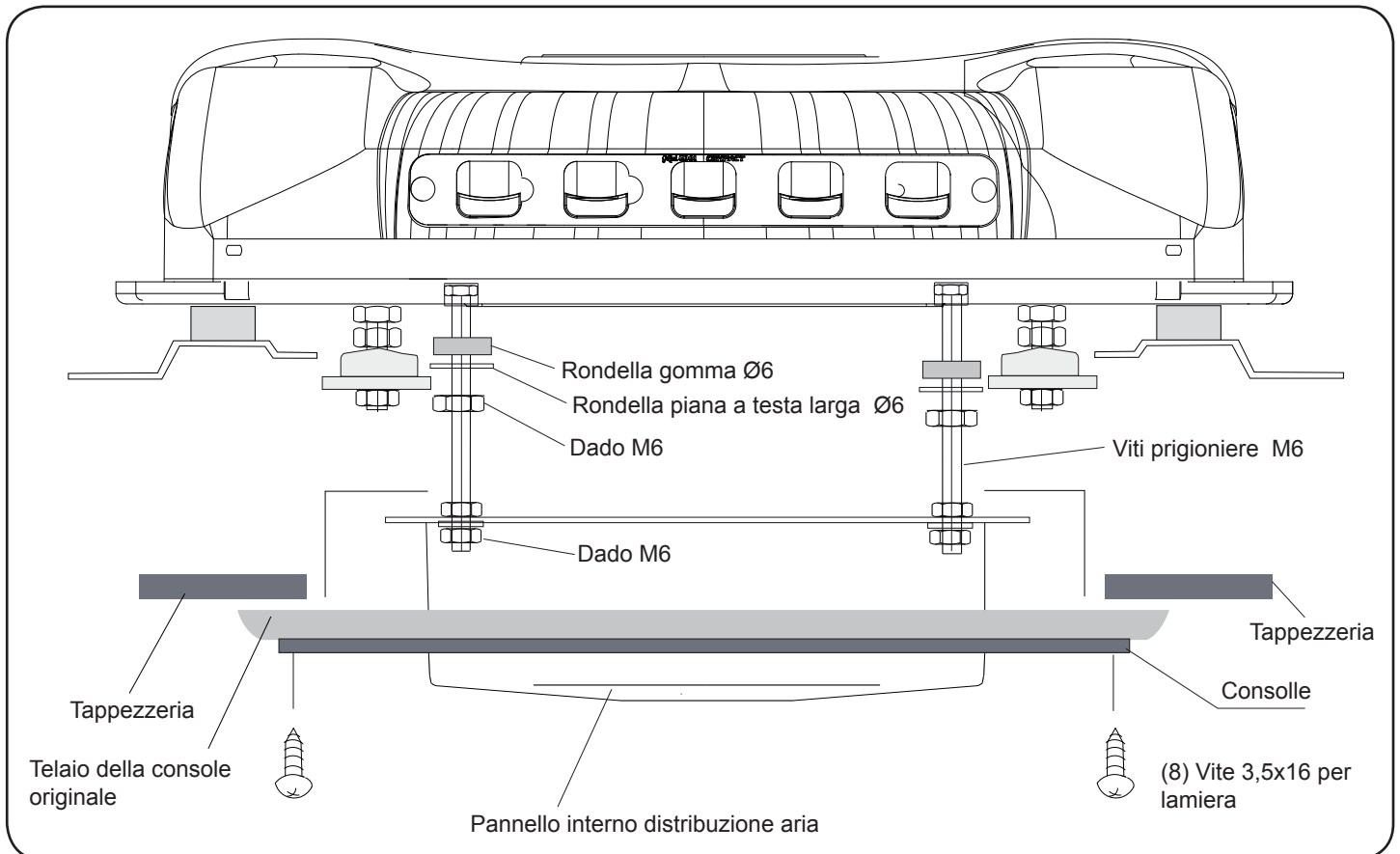

## Istruzioni dettagliate per l'installazione del cablaggio di alimentazione

**1**

Collegare il cavo di alimentazione superiore sulla parte posteriore dell'impianto e farlo passare dalla parte posteriore della cabina incollando i supporti di plastica e fissandolo con le flange.

**2**

Collegare il cablaggio di alimentazione inferiore al morsetto del cablaggio di alimentazione superiore.





## Connessione alle batterie posteriori

- 3** Condurre il cavo positivo (blu) alla scatola di giunzione nella posizione X3. Tagliare il tratto di cavo che avanza, aggraffare il terminale  $\varnothing 6$  in dotazione e collegarlo insieme al tratto del fusibile. Fissare il cavo nella posizione X3 con la rondella e il dado autobloccante.

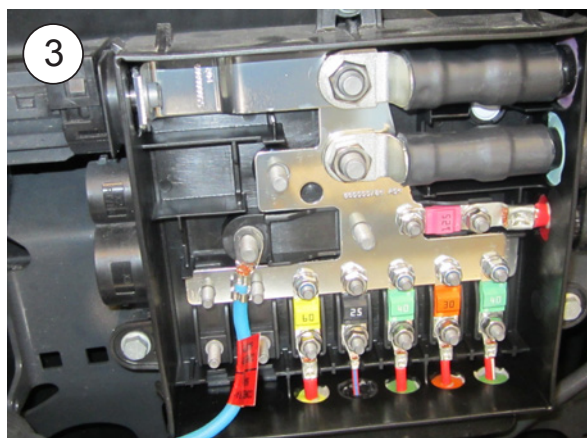
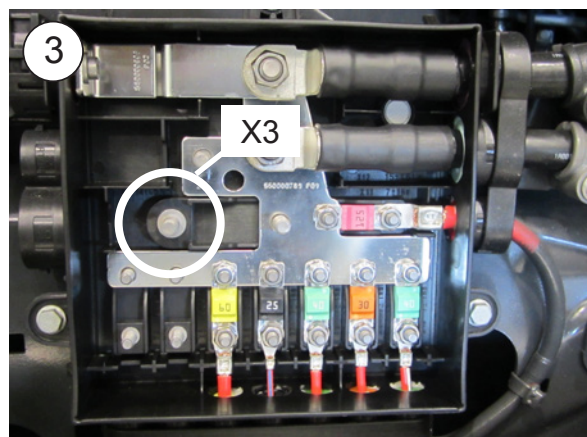
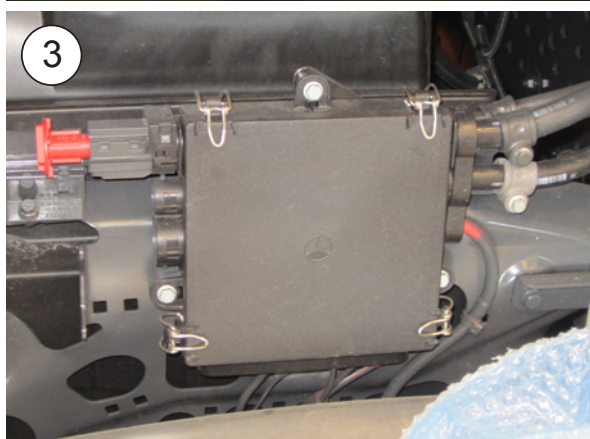
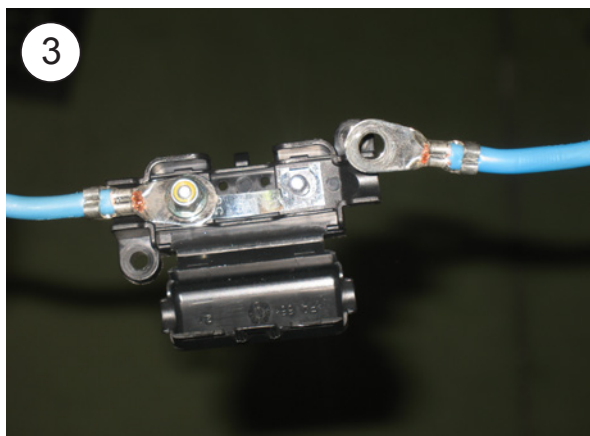

- 4** Condurre il cavo negativo (marrone) alla scatola di giunzione negativa situata vicino alle batterie. Fissare il cavo con la rondella e il dado autobloccante.



## Batterie anteriori

3

Condurre il cavo positivo (blu) alla scatola di giunzione (situata vicino alle batterie) nella posizione X3. Tagliare il tratto di cavo che avanza, aggraffare il terminale  $\varnothing 6$  in dotazione e collegarlo insieme al tratto del fusibile in dotazione. Fissare il cavo nella posizione X3 con la rondella e il dado autobloccante.

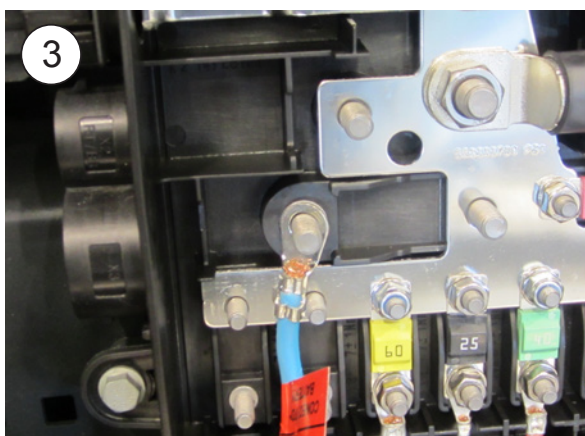
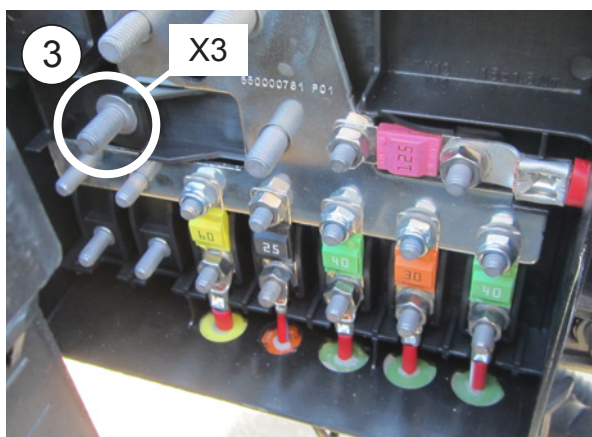

4

Condurre il cavo negativo (marrone) alla scatola di giunzione negativa situata vicino al morsetto negativo della batteria. Tagliare il tratto di cavo che avanza, aggraffare il terminale  $\varnothing 10$  e fissare con la rondella e il dado autobloccante.

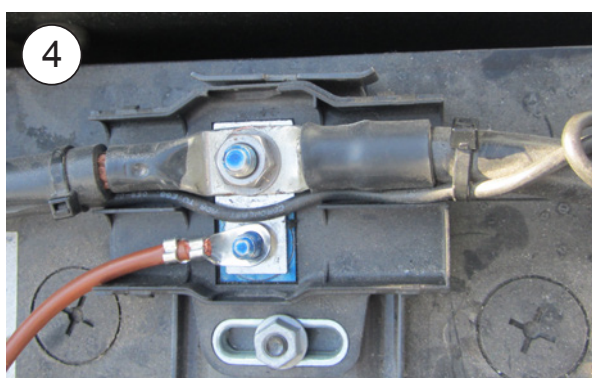
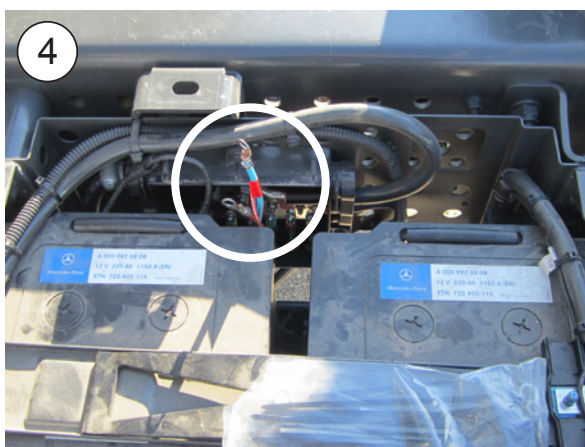



## Connessione diretta alle batterie

**3** Condurre il cavo positivo e quello negativo fino alla batteria facendoli passare dal passaggio originale dei cablaggi e fissandolo con le fascette.

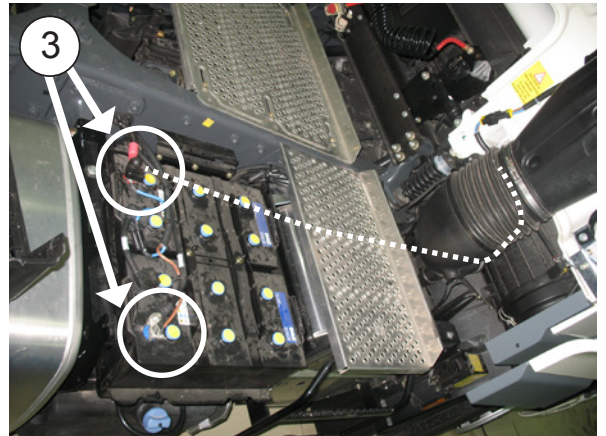

**4** Tagliare l'avanzo del cavo, fissare i terminali in dotazione e collegare.

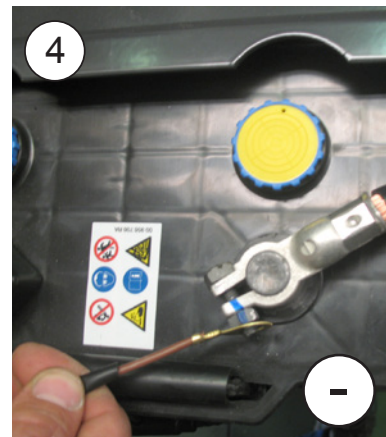

**ATTENZIONE:** Quando si collegano i cablaggi, lasciare la distanza necessaria per evitarne la rottura per i movimenti della cabina!  
**NOTA BENE:** Per l'avviamento, vedi il Manuale dell'utente.

**5** Piazzare gli adesivi indicanti il pericolo sulla giunzione del cablaggio e sul dispositivo di sollevamento della cabina.





# Cablaggio elettrico

## AVVISO IMPORTANTE!

Fare attenzione a non invertire le polarità effettuando la connessione dell'alimentazione all'impianto, altrimenti il quadro comandi non si accende, l'impianto non funziona e si potrebbero verificare danni irreparabili ai moduli dei compressori.

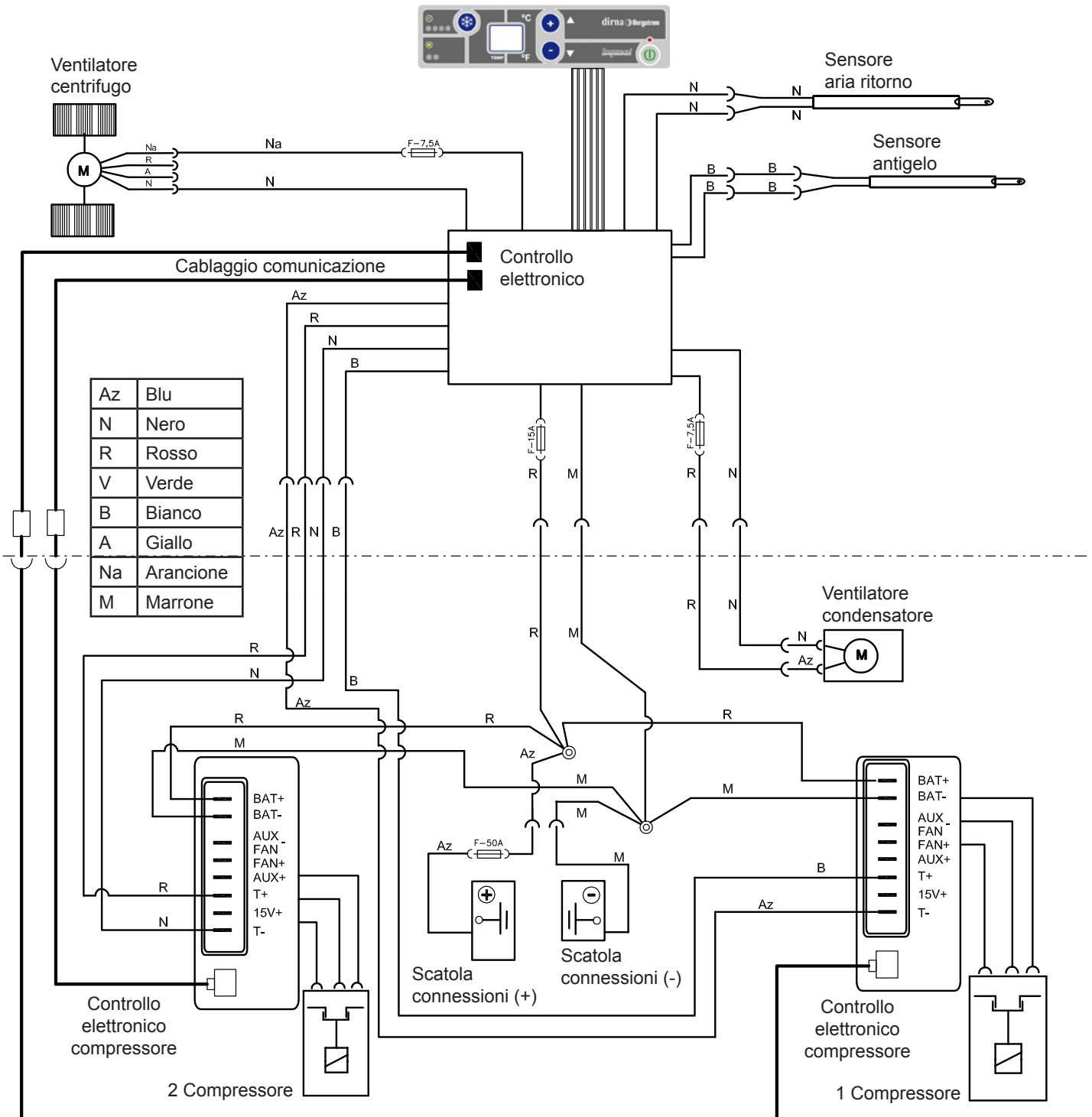



## Range of Products

# BYCOOL!

green line

### Air conditioning



**COMPACT 1.4**



**COMPACT 1.6**



**COMPACT 2.0**



**COMPACT 3.0**



# BYCOOL!

blue line

### Evaporative Cooler



**FLAT**



**REVOLUTION**



**CAMPER**



**MOCHILA**

Dirna Bergstrom es titular de todos los derechos de la presente información. La presente información es confidencial y queda prohibido cualquier acto de reproducción, distribución, comunicación pública y/o transformación de cualquier elemento de la misma sin la previa y expresa autorización de Dirna Bergstrom. Esta información ha de ser utilizada única y exclusivamente para el fin para el que fue creada, no siendo Dirna Bergstrom responsable de los posibles daños que se pudiera causar al cliente y/o a terceras partes por un incorrecto y/o inadecuado uso de la misma. Para cualquier aclaración al respecto pueden dirigirse al Centro de Comunicaciones del fabricante Dirna Bergstrom.

*DIRNA BERGSTROM is the holder of all the rights of this information. This information is confidential and it is absolutely forbidden any act of reproduction, distribution, public communication and/or transformation of any element of it without the previous and express authorization of DIRNA BERGSTROM. This information must be used only and exclusively for what it has been created, DIRNA BERGSTROM doesn't assume any responsibility of possible damages that could be caused to the client and/or third parties for a wrong and/or inadequate use of it. For any doubt about the aforementioned please contact DIRNA BERGSTROM by Communication Centre.*



Ed:	29/03/2012
Md:	27/07/2015

e



Francisco Alonso, 6  
28806 Alcalá de Henares, Madrid  
SPAIN

Contact	Phone	Fax	E-Mail
Sales (Ventas Internacional)	+34 91 8770510	+34 91 8771158	sales@dirna.bergstrominc.com
Comercial Nacional	+34 91 8775841	+34 91 8836321	ventas@dirna.bergstrominc.com
Orders & Deliveries (Logística internacional)	+34 91 8775846	+34 91 8771158	export@dirna.bergstrominc.com
Orders & Deliveries (Logística nacional)	+34 91 8775840	+34 91 8836321	comercial@dirna.bergstrominc.com
Technical Assistance (Internacional)	+49 511 86679681	+49 511 86679710	technicalassistance@dirna.bergstrominc.com
Technical Assistance (Nacional)	+34 91 8775845	+34 91 883 6321	jcastillo@dirna.bergstrominc.com

[www.dirna.com](http://www.dirna.com)  
[www.bycool.com](http://www.bycool.com)

	<b>ATENCIÓN:</b>	Dirna Bergstrom se reserva el derecho de efectuar modificaciones en cualquier momento de los datos contenidos en esta publicación, por razones técnicas o comerciales.
	<b>NOTE:</b>	<i>For technical and commercial reasons, Dirna Bergstrom reserves the right to change the data contained in this brochure.</i>
	<b>ATTENTION:</b>	Dirna Bergstrom se réserve le droit d'effectuer à tout moment des modifications des données reprises sur cette publication, pour des raisons techniques ou commerciales.
	<b>HIWEIS:</b>	<i>Dirna Bergstrom behält sich vor, aus technischen oder kaufmännischen Gründen jederzeit Änderungen der Angaben dieser Veröffentlichung vorzunehmen.</i>
	<b>ATTENZIONE:</b>	Dirna Bergstrom si riserva il diritto di effettuare modifiche in qualsiasi momento ai dati contenuti in questa pubblicazione, per motivi tecnici o commerciali.