

LITE

RENAULT T

Manual del usuario

User's handbook

Manuel de l'utilisateur

Benutzerhandbuch

Manuale per l'utente

Manual do utilizador

ES

EN

FR

GE

IT

PT

Gracias por su adquisición y por confiar en nuestra gama de productos. **LITE** es un equipo de aire acondicionado diseñado y fabricado por **dirna Bergstrom** para ser utilizado a motor del vehículo parado durante los períodos de descanso a la sombra y/o por la noche.

El único mantenimiento requerido es la limpieza periódica del condensador al menos 1 vez al año (1) (ver página 7).

LITE está diseñado con la más avanzada tecnología para lograr un eficaz rendimiento, una reducción en el gasto de combustible y en las emisiones de CO₂ a la atmósfera. Son estas características lo que lo hace único en el mercado del Aire Acondicionado para vehículos.

Si la temperatura en la cabina de su vehículo es muy elevada para el descanso, enfrie la cabina con el aire acondicionado del vehículo durante unos minutos y después conecte el **LITE** para mantener la temperatura de confort.

Para cualquier duda consulte a su **concesionario** o directamente a **dirna Bergstrom, s.l.**

No olvide solicitar a su concesionario su **tarjeta de garantía**.

**ATENCIÓN:**

Si durante el montaje el equipo se inclina o se abate la cabina con el equipo montado, se deberá esperar un mínimo de 60 minutos, desde que el equipo quede horizontal, antes de ponerlo en marcha.

(1) Para realizar esta operación, es necesario desmontar la tapa superior de plástico del equipo (8 tornillos roscachapa) y soplar con aire a presión. Es recomendable que esta operación la realice un Servicio Autorizado por **dirna Bergstrom, s.l.**

Panel de control

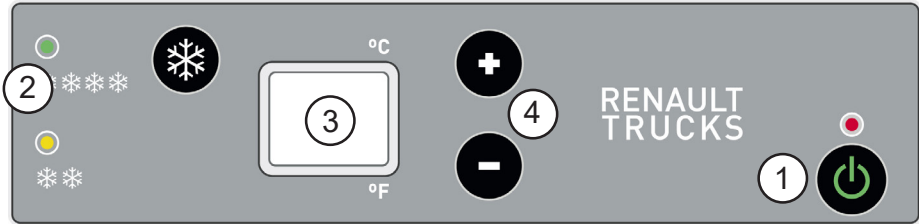

- 1.- **On/off:** encendido y apagado del equipo y selección de modos de funcionamiento.
 - 2.- Indica el funcionamiento del compresor.
 - 3.- **Display:** Pantalla donde se indica la función seleccionada y el estado del equipo.
 - 4.- **Selectores de temperatura:** Selección de la temperatura ambiente y la velocidad del soplador (esta sólo en modo manual), programación del mando y grados Fahrenheit.
- Al conectar, el equipo hace un chequeo de los leds y aparece en display **88--bd-Lr** y se apaga.

Mensajes especiales del display (por favor mirar Diagnósis de averías):

- : Batería baja.
- : Fallo electroventilador o soplador.
- : Fallo compresor.
- : Mal contacto de los cables de la sonda antihielo o sonda antihielo averiada.
- : Protección compresor (cabina abatida).
- : Mal contacto de los cables del sensor de aire de retorno o sensor de aire de retorno averiado.
- : Fallo cable de comunicaciones.

Mando a distancia

Funciones del Mando a distancia:



- ① Encendido / Apagado del equipo.
- ② Control de las velocidades del soplador.
- ③ Control de temperatura.







Dar de alta el mando a distancia:

Para dar de alta el mando a distancia, con el equipo apagado mantener pulsada la tecla del panel de control. Aparecerá en el display parpadeando. Cuando quede fijo, pulsar la tecla **On/Off** del mando antes de 30 seg. y el equipo emitirá una señal acústica de confirmación. En caso de que esto no suceda, repetir la operación completa.



Dar de baja el mando a distancia:

Para dar de baja el mando a distancia se debe mantener pulsada la tecla  del panel de control hasta que aparezca en el display , parpadeando, cuando quede fijo pulsar la tecla  del panel antes de 30 seg. o habrá que repetir la operación completa.



Funciones del equipo:





-  - Función manual.
-  - Función termómetro digital.
-  - Función programadora de tiempo
-  - Función funcionamiento automático del equipo.
-  - Función Selección ° F.









Encendido del equipo

Pulsar la tecla **On/Off**  del panel de control o del mando. El equipo siempre arranca en Función  (Función Automática). Para cambiar de función se debe mantener pulsado continuamente **On/Off**  del panel de control, irán apareciendo las distintas funciones en el display, soltar al obtener la función deseada. En la primera puesta en marcha el equipo se iniciará con los parámetros establecidos de fábrica.

Función - Funcionamiento Manual

Al seleccionar  en el display se muestra la temperatura seleccionada y le permite al usuario elegir la temperatura de confort que aparecerá en el display de 15°C a 27°C o 59°F a 71°F así como variar la velocidad del soplador del equipo (5 velocidades señaladas con las siglas  a .





La temperatura de confort se controla pulsando las teclas   del panel de control o   del mando.

Las velocidades del soplador será controlado manteniendo pulsadas las teclas   o del panel de control o desde  del mando apareciendo en el display las siglas , , , , . Cuando el equipo está en funcionamiento aparecerá en el display los grados seleccionados.







Función - Función termómetro digital

Seleccionando esta función se indica en su display la temperatura interior de la cabina.





Función F2 - Función Programadora de tiempo

F2 programa al **equipo** para su desconexión automática en un período de entre 1 y 9 horas. Para programar mantener pulsada la tecla **On/Off**  hasta visualizar en el display F2, seleccionar el tiempo de funcionamiento con las teclas   y confirmar pulsando **On/Off** .

Función F4 - Funcionamiento automático del equipo

Al seleccionar F4 le permite al usuario elegir la temperatura de confort 15°C a 27°C, o 59°F a 71°F que seleccionará desde las teclas   del panel de control o de las teclas   del mando. Al seleccionar aparecerá en el display intercalados  y los grados seleccionados. Con esta función el equipo regula y controla automáticamente la temperatura de confort actuando sobre las velocidades del ventilador y los compresores. Pulsando la tecla  del mando a distancia se anula la función F4 y pasa a F0 (Función Manual).

Función F5 - Selección °F

Para activar esta función se debe mantener pulsada la tecla **On/off**  hasta que aparezca en el display F5, soltar la tecla y se activará directamente °F. Para volver a °C se debe mantener pulsada la tecla  del panel de mandos con el equipo apagado, aparecerá en el display  parpadeando, cuando se quede fijo pulsar la tecla  del panel de mando. Al realizar esta operación el mando se desactiva por lo que al finalizar se debe dar de alta el mando.

Esquema eléctrico

¡AVISO IMPORTANTE!

Precaución de no invertir las polaridades al conectar el equipo a la batería. Si esto sucediera la placa no se enciende y el equipo no funciona.

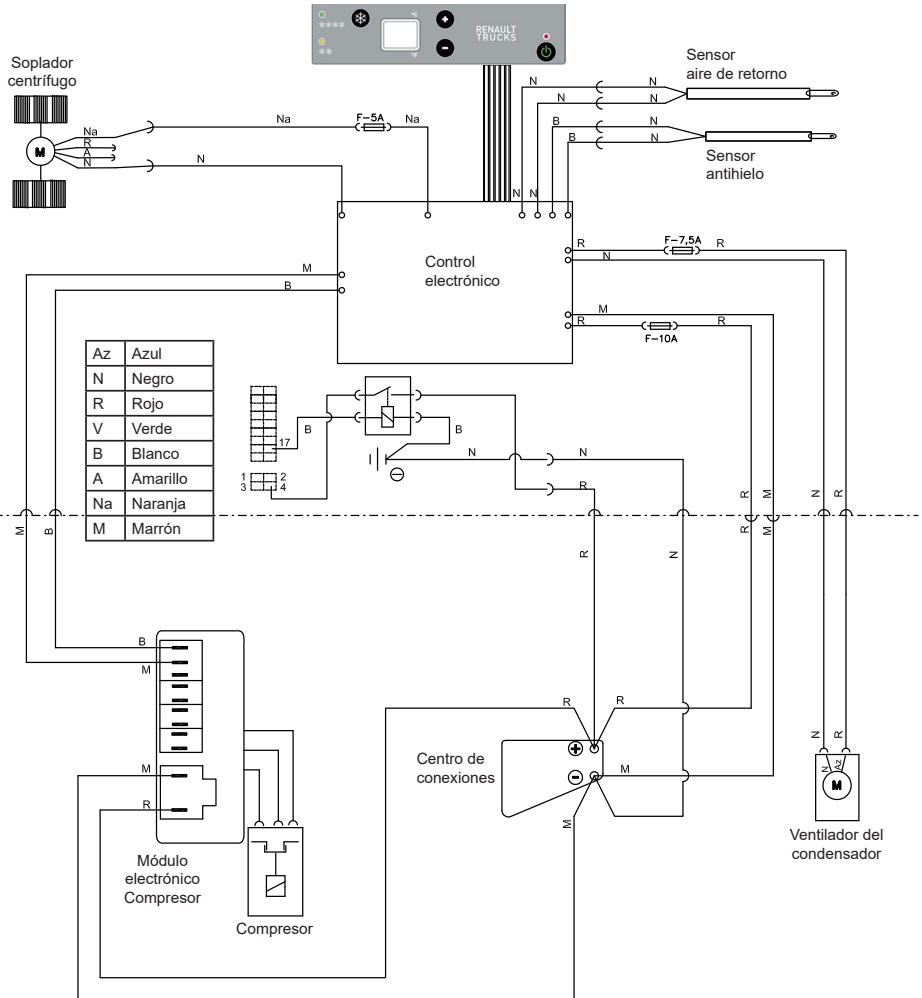

Para limpiar el condensador (*) es necesario desmontar la tapa superior del equipo (8 tornillos roscachapa) y soplar con aire a presión el condensador. Es recomendable que ésta operación la realice un servicio autorizado por **dirna Bergstrom**.

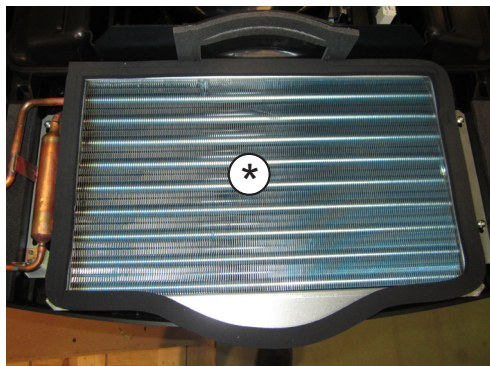

Thank you for your purchase and for placing your trust in our range of products. **LITE** is an air conditioning unit designed and manufactured by **dirna Bergstrom** to run off a stationary vehicle's engine during rest periods in the shade and/or at night.

The only maintenance required is periodic cleaning of the condenser at least once per year (1) (see page 13).

LITE is designed with cutting-edge technology to achieve high performance, reduced fuel consumption and a lower level of CO₂ emissions. These are the features which make it unique on the vehicle air conditioning market.

If the temperature in the vehicle cabin is too hot for comfort, cool down the cabin with the vehicle's air conditioning for a few minutes and then connect the **LITE** to maintain this comfort temperature.

For any questions, ask your **dealer** or contact **dirna Bergstrom, s.l.** directly.

Remember to ask your dealer for your **warranty card**.



CAUTION:

If the cabin is tilted during assembly with the unit in place, wait for at least 60 minutes with the unit in horizontal position before starting it up.

(1) In order to carry out this operation, first take down the unit's plastic top cover (8 self-tapping screws) and blow with pressurised air. We recommend entrusting this operation to a technical service authorised by **dirna Bergstrom, s.l.**

Control panel

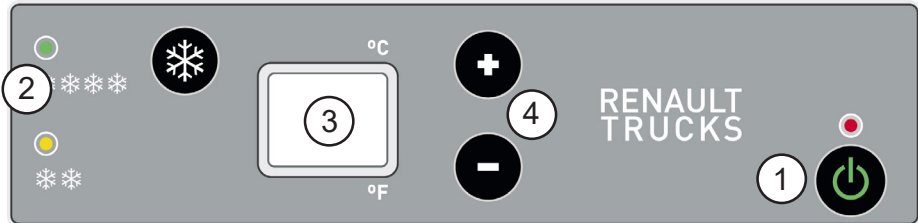

- 1.- **On/off:** turn the unit on and off and select operation mode.
- 2.- Indicates compressor operation.
- 3.- **Display:** Screen indicating the selected function and the status of the unit.
- 4.- **Temperature selectors:** Select cabin temperature and blower speed (in manual mode only), programme the remote control and degrees Fahrenheit.

• When connecting, the unit checks the LEDs, displays **88--bd-Lr** and goes off.

Special display messages (please check *Troubleshooting*):

: Low battery.

: Electrofan or blower failure.

: Compressor failure.

: Poor contact of anti-freeze sensor cables or anti-freeze sensor failed.

: Compressor protection (cabin tilted).

: Poor contact of the return air sensor cables, or return air sensor faulty.

: Communications cable failure.



Remote control

Remote control functions:



- ① Unit on/off.
- ② Blower speed control.
- ③ Temperature control.



Activate the remote control:

To activate the remote control, keep the  key on the control panel pressed down with the unit off. The display will show  flashing. When it stops flashing, press the  **On/Off** key on the remote control within 30 seconds and the unit will give out an audible confirmation signal. If this does not happen, repeat the whole operation.



Remove the remote control:

To remove the remote control, keep the  key on the control panel pressed down until the display flashes , when it stops flashing, press the  key on the panel before 30 seconds have passed or it will be necessary to repeat the complete operation.



Unit functions:





- F0 - Manual function.
- F1 - Digital thermometer function.
- F2 - Time programming function.
- F4 - Unit automatic operation function.
- F6 - °F Selection function.









Turning the unit on

Press the **On/Off**  key on the control panel or remote control. The unit always starts up in Function F4 (Automatic Function). To change function, keep **On/Off**  pressed down on the control panel, passing through the different functions on the display, and release when the required function is shown. When running for the first time, the unit will start up with the default parameters.

Function F0 - Manual operation

Selecting F0 in the display shows the selected temperature and allows the user to choose the comfort temperature which will be displayed, from 15°C to 27°C or 59°F to 71°F, and to change the unit's blower speed (5 speeds indicated with the characters  to .





Comfort temperature is controlled by pressing the keys   on the control panel or   on the remote control.

The centrifugal blower speeds will be controlled by keeping the   keys on the control panel pressed down or from  on the remote control, with the display showing , , , , . The display shows the degrees selected when the unit is running.







Function F1 - Digital thermometer function

The interior cabin temperature is displayed when selecting this function.





Function F2 - Time programming function

F2 programmes the unit for automatic disconnection in a period of 1 to 9 hours. Programme by keeping the **On/Off**  key pressed down until F2 is displayed, then select operation time using the   keys and confirm by pressing **On/Off** .

Function F4 - Automatic unit operation

Selecting F4 allows the user to choose the comfort temperature 15°C to 27°C (59°F to 71°F), which will be selected from the control panel   keys or the remote control   keys. When selecting, the display will switch between  and the degrees selected. With this function the unit automatically regulates and controls comfort temperature by acting on the compressors and fan speed. Pressing the  key on the remote control cancels function F4 and moves to F0 (Manual Function).

Function F6 - °F Selection

To activate this function, keep the **On/off**  key pressed down until the display shows F6, and then release the key to directly enable °F. To return to °C, keep the control panel  key pressed down with the unit switched off, at which point  will flash; when it stops flashing, press the  key on the control panel. The remote control is disabled when carrying out this operation, meaning it must be registered once finished.

Electric wiring

IMPORTANT WARNING!

Take care not to invert polarities when connecting the unit to the power supply. If this happens, the plate does not come on and the unit does not work.

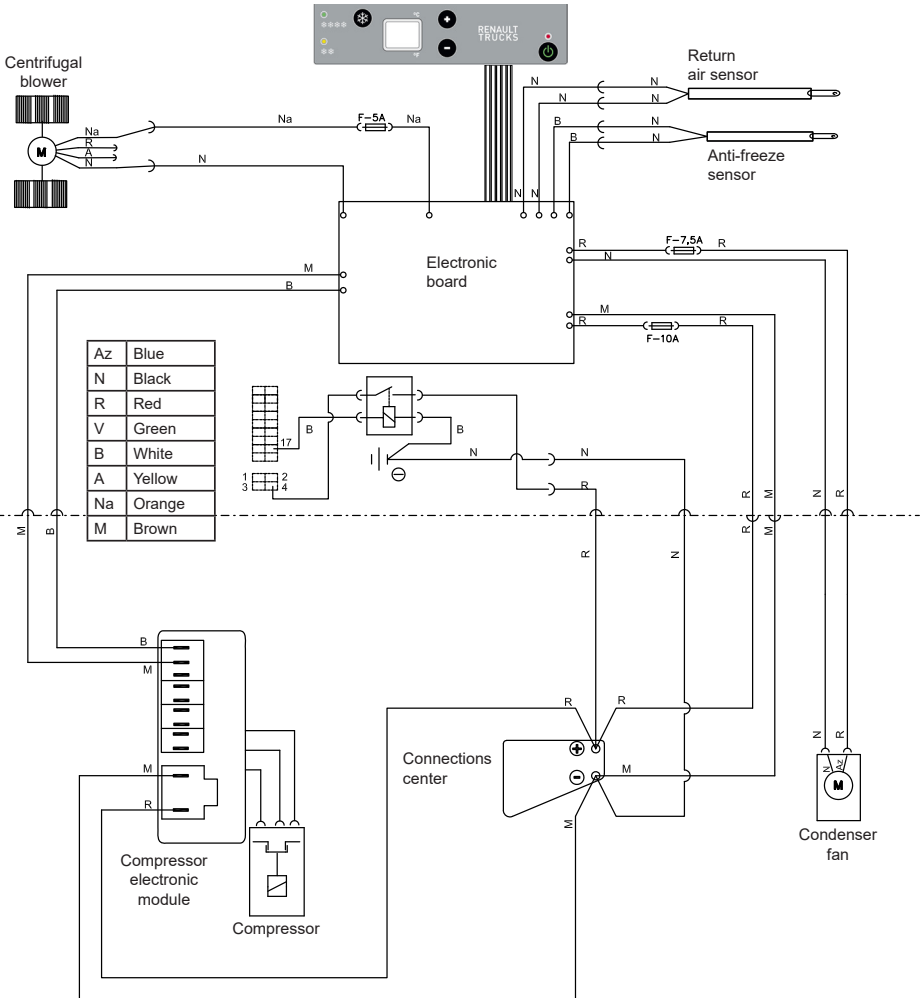

To clean the condenser (*) remove the top cover of the equipment (8 sheet metal screws) and blow the condenser with compressed air. This operation should be performed by a **dirna Bergstrom** authorized service.

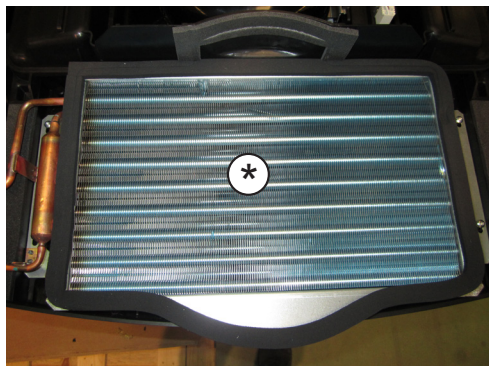

Merci de l'achat et de la confiance accordée à notre gamme de produits. **LITE** est un appareil d'air conditionné conçu et fabriqué par **dirna Bergstrom** pour être utilisé avec le moteur du véhicule à l'arrêt durant les périodes de repos à l'ombre et/ ou la nuit.

La seule maintenance requise est le nettoyage régulier du condenseur au moins une fois par an (1) (voir page 19).

LITE est conçu avec la technologie la plus avancée pour obtenir un rendement efficace, une réduction des frais de carburant et des émissions de CO₂ à l'atmosphère. C'est grâce à ces caractéristiques qu'il est unique sur le marché de l'Air Conditionné pour véhicules.

Si la température dans la cabine du véhicule est très élevée pour permettre le repos, refroidissez la cabine avec l'air conditionné du véhicule durant quelques minutes puis branchez **LITE** pour maintenir la température de confort.

N'hésitez pas à consulter votre **concessionnaire**, quelles que soient vos questions, ou directement **dirna Bergstrom, s.l.**

N'oubliez pas de demander à votre concessionnaire la **carte de garantie**.

**ATTENTION:**

Si durant le montage l'appareil est incliné ou si la cabine est rabattue avec l'appareil monté, il faudra attendre au moins 60 minutes, depuis que l'appareil est horizontal avant de le mettre en marche.

(1) Pour effectuer cette opération, il faut démonter le couvercle supérieur en plastique de l'appareil (8 vis taraudeuses) et souffler avec de l'air à pression. Il est conseillé de faire exécuter cette opération par un Service Agréé par **dirna Bergstrom, s.l.**

Panneau de contrôle

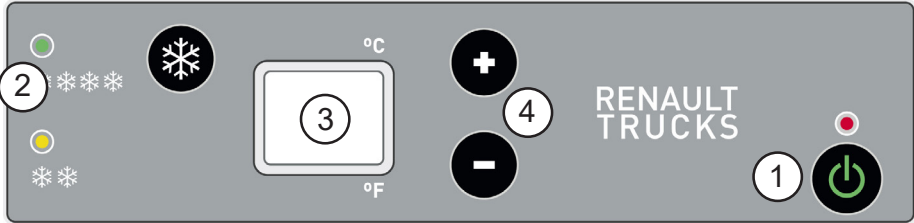

- 1.- **On/off**: mise en marche et arrêt de l'appareil et sélection des modes de fonctionnement.
 - 2.- Indique le fonctionnement du compresseur.
 - 3.- **Affichage**: Ecran sur lequel est indiquée la fonction sélectionnée ainsi que l'état de l'appareil.
 - 4.- **Sélecteurs de température**: Sélection de la température ambiante et de la vitesse du souffleur (uniquement en mode manuel), programmation de la commande et degrés Fahrenheit.
- A la mise en service, l'appareil effectue une vérification des leds et **88--bd-Lr** apparaît à l'affichage qui ensuite s'éteint.

Messages spéciaux à l'affichage (prière de voir la section *Diagnostic des pannes*):

: Batterie basse.

: Défaut électroventilateur ou souffleur.

: Défaut compresseur.

: Mauvais contact des câbles de la sonde antigel ou sonde antigel en panne.

: Protection compresseur (cabine rabattue).

: Mauvais contact des câbles du capteur d'air de retour ou capteur d'air de retour en panne.

: Défaut câble de communications.



Télécommande

Fonctions de la Télécommande:



- ① Mise en marche /arrêt de l'appareil.
- ② Contrôle des vitesses du souffleur.
- ③ Contrôle de température.







Enregistrer la télécommande:

Pour enregistrer la télécommande, quand l'appareil est éteint, appuyez et maintenez la touche  du panneau de commande. Il apparaîtra à l'affichage  clignotant. Quand celui-ci reste fixe, appuyez sur la touche **On/Off**  de la commande dans les 30 sec. qui suivent et l'appareil émettra un signal sonore de confirmation. Si ce n'est pas le cas, recommencez l'opération complète.



Supprimer la télécommande:

Pour supprimer la télécommande, il faut appuyer et maintenir la touche  du panneau de commande jusqu'à ce que  apparaisse à l'affichage, en clignotant; quand il devient fixe, appuyez sur la touche  du panneau dans les 30 sec qui suivent, sinon il faudra recommencer l'opération complète.



Fonctions de l'appareil:





-  - Fonction manuelle.
-  - Fonction thermomètre numérique.
-  - Fonction de programmation de temps
-  - Fonction de fonctionnement automatique de l'appareil.
-  - Fonction de Sélection ° F.









Mise en marche de l'appareil

Appuyez sur la touche **On/Off**  du panneau de commande ou de la commande. L'appareil démarre toujours en Fonction  (Fonction Automatique). Pour changer de fonction, il faut appuyer et maintenir de façon continue sur **On/Off**  du panneau de commande, les différentes fonctions défilent à l'affichage, relâchez la touche quand vous atteignez la fonction désirée. A la première mise en marche, l'appareil démarrera avec les paramètres établis en usine.

Fonction - Fonctionnement Manuel

En sélectionnant , la température sélectionnée est affichée et l'utilisateur peut choisir la température de confort qui apparaîtra à l'affichage de 15°C à 27°C ou 59°F à 71°F, de même que la vitesse du souffleur de l'appareil (5 vitesses signalées par les sigles  à ).





La température de confort est contrôlée à l'aide des touches   du panneau de commande ou   de la commande.

Les vitesses du souffleur seront contrôlées en appuyant et maintenant les touches   ou sur le panneau de commande ou de  de la commande et à l'affichage les sigles , , , ,  apparaîtront. Quand l'appareil est en service, les degrés sélectionnés sont affichés.







Fonction - Fonction thermomètre numérique

En sélectionnant cette fonction, l'affichage indique la température intérieure de la cabine.





Fonction F2 - Fonction Programmeur de temps

F2 programme l'appareil pour la déconnection automatique sur une période d'entre 1 et 9 heures. Pour programmer, appuyez et maintenez la touche **On/Off**  jusqu'à voir affiché F2, sélectionnez le temps de fonctionnement avec les touches   puis confirmez en appuyant sur **On/Off** .

Fonction F4 - Fonctionnement automatique de l'appareil

En sélectionnant F4 l'utilisateur peut choisir la température de confort de 15°C à 27°C ou 59°F à 71°F qu'il sélectionnera à l'aide des touches   du panneau de contrôle ou des touches   de la commande. Lors de la sélection,  et les degrés sélectionnés s'afficheront intercalés. Cette fonction permet à l'appareil de régler et de contrôler automatiquement la température de confort en agissant sur les vitesses du ventilateur et les compresseurs. En appuyant sur la touche  de la télécommande, la fonction F4 est annulée et l'appareil passe à F0 (Fonction Manuelle).

Fonction F6 - Sélection °F

Pour activer cette fonction, il faudra appuyer et maintenir la touche **On/Off**  jusqu'à ce qu'apparaisse F6 à l'affichage puis relâcher la touche, °F s'affichera automatiquement. Pour revenir à °C, il faudra appuyer et maintenir la touche  du panneau de commande quand l'appareil est éteint,  s'affichera en clignotant, quand il devient fixe, appuyez sur la touche  du panneau de commande. Avec cette opération, la commande est désactivée, par conséquent, une fois terminé, il faudra activer à nouveau la commande.

Câblage électrique

AVERTISSEMENT IMPORTANT!

Attention de ne pas inverser les polarités au moment de connecter l'alimentation à l'équipement. Si cela se produisait, la plaque ne s'allumerait pas et l'équipement ne fonctionnerait pas.

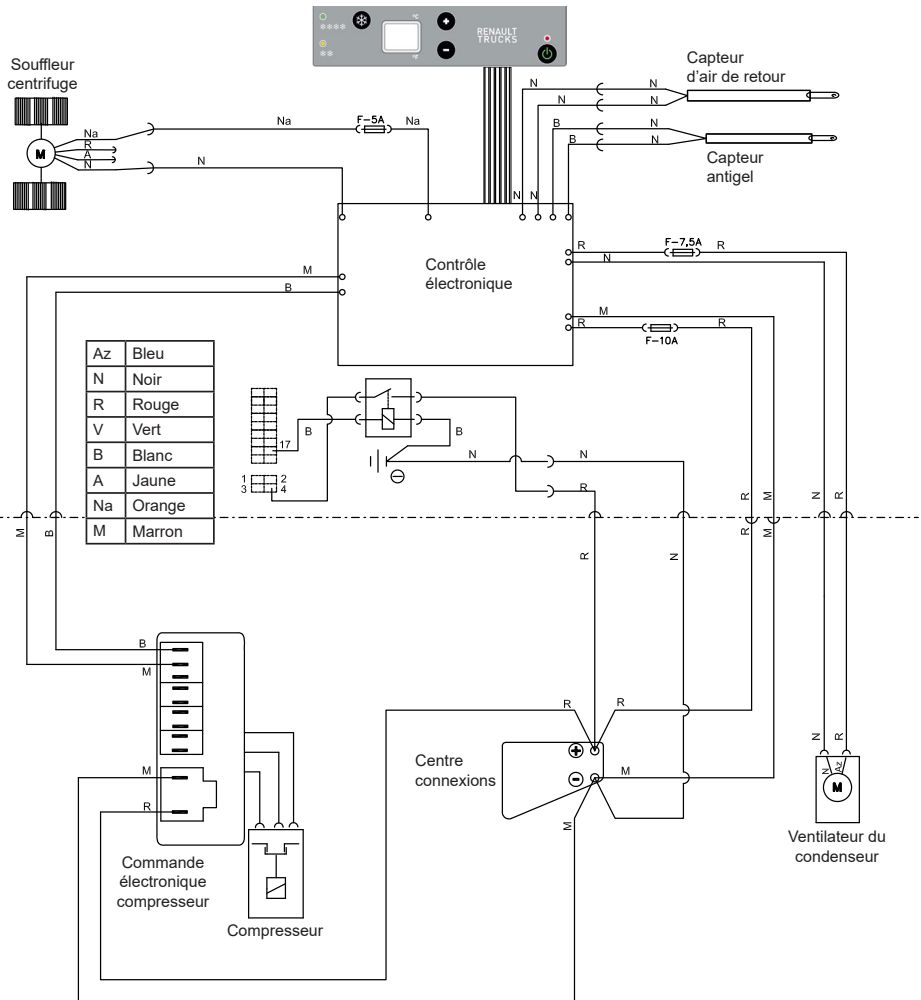

Pour nettoyer le condenseur(*), il faut démonter le couvercle supérieur de l'équipement (8 vis auto-fileteuses) et souffler avec de l'air sous pression le condenseur. Cette opération devrait être réalisée par un Service Autorisé par **dirna Bergstrom**.

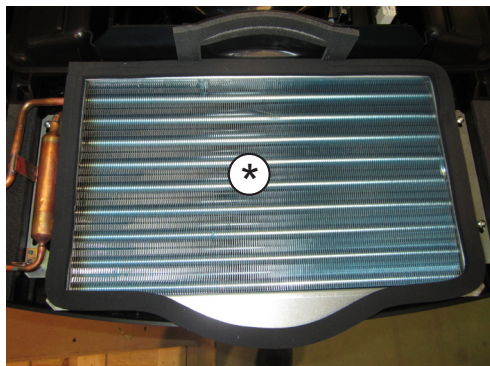

Grazie per l'acquisto e per la fiducia riposta nella nostra gamma di prodotti. **LITE** è un impianto di aria condizionata progettato e prodotto da **dirna Bergstrom** per essere usato con il motore del veicolo fermo durante i periodi di sosta all'ombra e/o di notte.

L'unica manutenzione richiesta è la pulizia periodica del condensatore, da effettuare almeno 1 volta all'anno (1) (vedi pag. 25).

LITE è progettato con la tecnologia più avanzata per ottenere un rendimento efficace, ridurre i consumi di combustibile e le emissioni di CO₂ in atmosfera. Sono queste caratteristiche che lo rendono unico nel mercato dell'aria condizionata per veicoli.

Se la temperatura nella cabina del veicolo è molto elevata per poter riposare, è possibile raffreddare la cabina con l'aria condizionata del veicolo per qualche minuto e poi inserire **LITE** per mantenere la temperatura di comfort.

Per qualsiasi dubbio, rivolgersi al **concessionario** o direttamente a **dirna Bergstrom, s.l.**

Non dimenticare di richiedere al concessionario la **scheda di garanzia**.

**ATTENZIONE:**

Se durante il montaggio si inclina l'impianto o si ribalta la cabina con l'impianto montato, prima di rimettere in funzione l'impianto occorre attendere almeno 60 minuti dal momento in cui è di nuovo in posizione orizzontale.

(1) Per eseguire questa operazione, è necessario smontare il coperchio esterno di plastica dell'impianto (8 viti per lamiera) e soffiare con aria a pressione. È consigliabile affidare l'esecuzione di questa operazione ad un Servizio Tecnico autorizzato da **dirna Bergstrom, s.l.**

Pannello di controllo

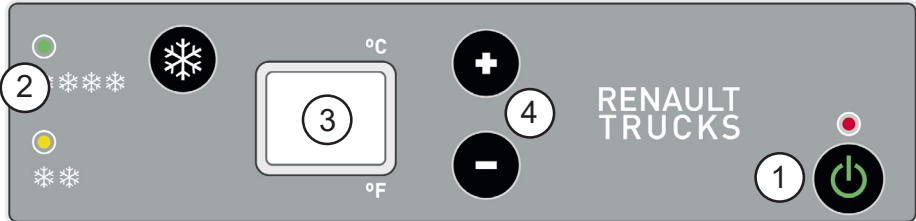

- 1.- **On/off:** accensione e spegnimento dell'impianto e selezione delle modalità di funzionamento.
 - 2.- Indica il funzionamento del compressore.
 - 3.- **Display:** Schermo sul quale sono indicati la funzione selezionata e lo stato dell'impianto.
 - 4.- **Selettori della temperatura:** Selezione della temperatura ambiente e della velocità del ventilatore (quest'ultima solo in funzionamento manuale), programmazione del comando e gradi Fahrenheit.
- All'accensione, l'impianto esegue un controllo dei led, sul display **88--bd-Lr** e si spegne.

Messaggi speciali del display (vedi *Diagnosi dei guasti*):

: Batteria quasi scarica.

: Guasto elettroventilatore o ventola.

: Guasto compressore.

: Contatto errato dei cavi della sonda antigelo o guasto alla stessa.

: Protezione compressore (cabina ribaltata).

: Contatto errato dei cavi del sensore dell'aria di ritorno o sensore di aria di ritorno guasto.

: Guasto cavo comunicazioni.



Telecomando

Funzioni del telecomando:



- ① Accensione / Spegnimento dell'impianto.
- ② Controllo delle velocità della ventola.
- ③ Controllo della temperatura.







Attivazione del telecomando:

Per attivare il telecomando, con l'impianto spento, mantenere premuto il tasto  dal quadro comandi. Sul display compare  lampeggiando. Quando è fisso, premere il tasto **On/Off**  del telecomando entro 30 secondi e l'impianto emette un segnale acustico di conferma. In caso contrario, ripetere da capo queste operazioni.



Disattivazione del telecomando:

Per disattivare il telecomando, mantenere premuto il tasto  del pannello di controllo finché sul display non compare , lampeggiando; quando resta fisso premere il tasto  entro 30 secondi. In caso contrario, ripetere da capo queste operazioni.



Funzioni dell'impianto:





-  - Funzionamento manuale.
-  - Funzione termometro digitale.
-  - Funzione impostazione del tempo.
-  - Funzionamento automatico dell'impianto.
-  - Funzione selezione ° F.









Accensione dell'impianto

Premere il tasto **On/Off**  dal pannello di controllo o dal telecomando. L'impianto si avvia sempre nella modalità  (funzionamento automatico). Per cambiare funzione, occorre mantenere premuto continuamente **On/Off**  sul quadro comandi e rilasciarlo quando sul display compare la funzione richiesta. Quando si avvia per la prima volta, l'impianto è impostato con i parametri programmati di fabbrica.

Funzione - Funzionamento manuale

Selezionando  sul display è indicata la temperatura selezionata e l'utente può impostare la temperatura di comfort che compare sul display (da 15°C a 27°C o da 59°F a 71°F) e di modificare la velocità della ventola dell'impianto (5 velocità contraddistinte dalle sigle da  a ).





La temperatura di comfort si controlla premendo brevemente i tasti   dal quadro comandi o   dal telecomando.

Le velocità della ventola si controllano mantenendo premuti i tasti   dal quadro comandi o  dal telecomando; sul display compaiono le sigle , , , , . Quando l'impianto è in funzione, sul display compaiono i gradi impostati.





Funzione - Funzione termometro digitale

Selezionando questa funzione, sul display compare la temperatura interna della cabina.

Funzione F2 - Funzione impostazione del tempo





Con F2 si imposta il disinserimento automatico dell'impianto entro un periodo di tempo compreso tra 1 e 9 ore. Per l'impostazione, mantenere premuto il tasto **On/Off**  sul display, quindi selezionare il tempo di funzionamento con i tasti   e confermare premendo **On/Off** .

Funzione F4 - Funzionamento automatico dell'impianto

Selezionando F4 l'utente può impostare la temperatura di comfort da 15°C a 27°C, o da 59°F a 71°F con i tasti   dal quadro comandi o i tasti   dal telecomando. Una volta selezionata la funzione, sul display si intercalano  e i gradi selezionati. Con questa funzione l'impianto imposta e controlla automaticamente la temperatura di comfort intervenendo sulla velocità della ventola e sui compressori.

Premendo il tasto  del telecomando se annulla la funzione F4 e si passa a F0 (funzionamento manuale).

Funzione F5 - Selezione °F

Per attivare questa funzione, mantenere premuto il tasto **On/off**  fino alla comparsa di F5 sul display: rilasciare quindi il tasto per attivare direttamente °F. Per ripristinare i °C, mantenere premuto il tasto  dal quadro comandi con l'impianto spento e sul display compare  lampeggiando: quando smette di lampeggiare, premere il tasto  dal quadro comandi. Quando si esegue questa operazione, il telecomando si disattiva perciò alla fine occorre riattivarlo.

Cablaggio elettrico

AVVISO IMPORTANTE!

Fare attenzione a non invertire le polarità quando si esegue il collegamento dell'impianto. Infatti, in tal caso il quadro comandi non si accende e l'impianto non funziona.

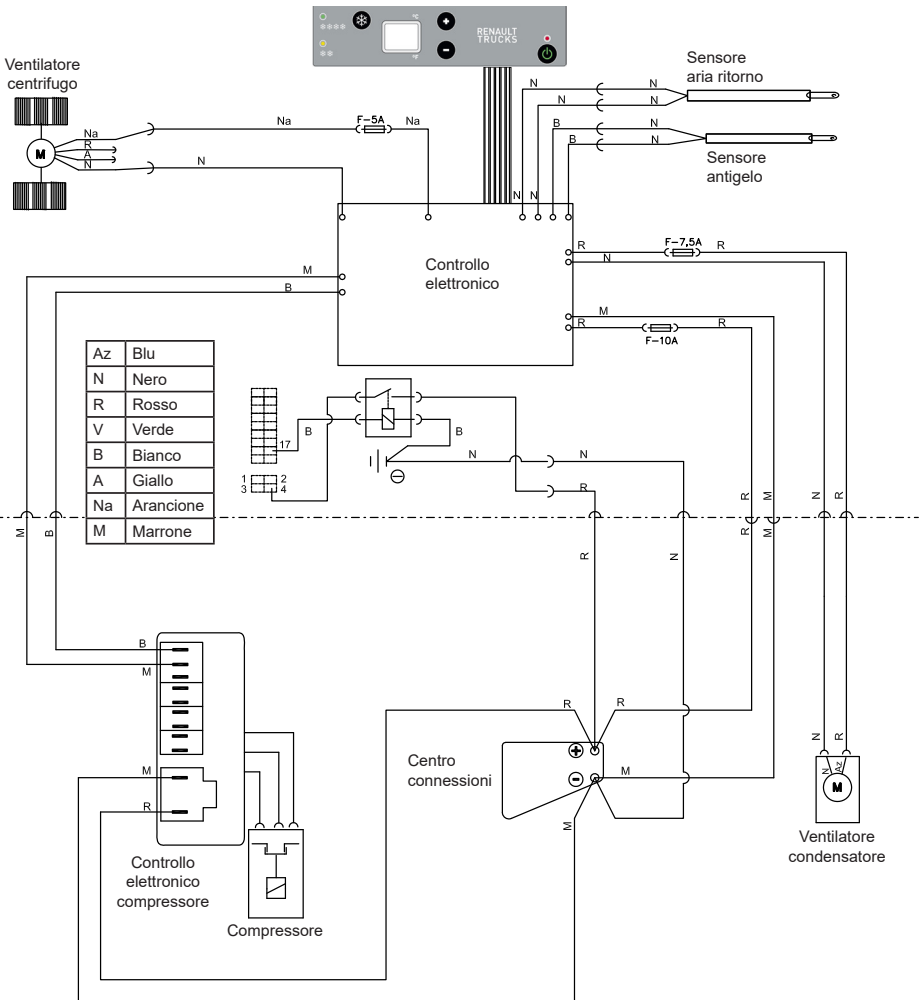

Per pulire il condensatore (*) è necessario smontare il coperchio superiore dell'impianto (8 viti per lamiera) e poi soffiare aria a pressione sul condensatore. È consigliabile affidare l'esecuzione di questa operazione ad un Servizio Tecnico autorizzato da **dirna Bergstrom**.

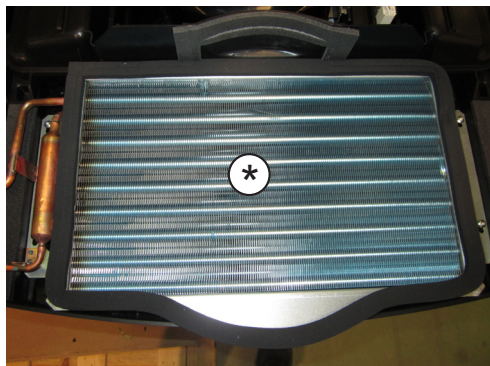

Obrigado pela sua aquisição e por confiar na nossa gama de produtos. **LITE** é um equipamento de ar condicionado concebido e fabricado pela **dirna Bergstrom** para ser utilizado no motor do veículo parado durante os períodos de descanso à sombra e/ou à noite.

A única manutenção necessária é a limpeza regular do condensador, pelo menos 1 vez por ano (1) (ver página 37).

LITE foi concebido com a mais avançada tecnologia para obter um rendimento eficaz, uma redução no gasto de combustível e nas emissões de CO2 para a atmosfera. São estas características que o tornam único no mercado do Ar Condicionado para veículos.

Se a temperatura na cabina do seu veículo for muito elevada para o descanso, arrefeça a cabina com o ar condicionado do veículo durante alguns minutos e depois ligue o **LITE** para manter a temperatura de conforto.

Para qualquer dúvida consulte o seu **concessionário** ou diretamente a **dirna Bergstrom, s.l.**

Não hesite solicitar o **cartão de garantia** ao seu concessionário.



ATENÇÃO:

Se durante a montagem o equipamento ficar inclinado ou a cabina abater com o equipamento montado, aguardar pelo menos 60 minutos, desde que o equipamento fique horizontal, antes de colocá-lo em funcionamento.

(1) Para realizar esta operação é necessário desmontar a tampa superior de plástico do equipamento (8 parafusos rosca chapa) e soprar com ar de pressão. É recomendável que esta operação seja realizada por um Serviço Autorizado pela **dirna Bergstrom, s.l.**

Painel de controlo

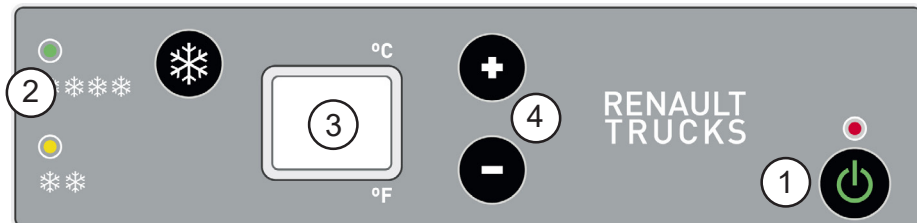

- 1.- **On/off:** ligação e desligação do equipamento e seleção de modos de funcionamento.
 - 2.- Indica o funcionamento do compressor.
 - 3.- **Visor:** ecrã onde é indicada a função selecionada e o estado do equipamento.
 - 4.- **Seletores de temperatura:** seleção da temperatura ambiente e da velocidade do soprador (*esta apenas no modo manual*), programação do comando e graus Fahrenheit.
- Ao ligar, o equipamento faz uma verificação dos LEDs e aparece no visor **88--bd-Lr** e desliga-se.

Mensagens específicas do visor (ver *Diagnóstico de avarias*):

: Bateria fraca.

: Falha eletroventilador ou soprador.

: Falha compressor.

: Mau contacto dos cabos da sonda anti-gelo ou sonda anti-gelo avariada.

: Proteção compressor (cabina abatida).

: Mau contacto dos cabos do sensor de ar de retorno ou sensor de ar de retorno avariado.

: Falha cabo de comunicações.



Comando à distância

Funções do comando à distância:



- ① Ligação / Desligação do equipamento.
- ② Controlo das velocidades do soprador.
- ③ Controlo da temperatura.



Ativar o comando à distância:

Para ativar o comando à distância, com o equipamento desligado, manter premida a tecla  do painel de controlo. Aparecerá no visor  a piscar. Quando ficar fixo, premir a tecla **On/Off**  do comando antes de 30 seg. e o equipamento emitirá um sinal acústico de confirmação. No caso de isto não acontecer, repetir a operação completa.



Desativar o comando à distância:

Para desativar o comando à distância deve manter premida a tecla  do painel de controlo até aparecer no visor  a piscar; quando ficar fixo premir a tecla  do painel antes de 30 seg. ou terá de repetir a operação completa.

Funções do equipamento:





- **F0** - Função manual.
- **F1** - Função termómetro digital.
- **F2** - Função programadora de tempo.
- **F4** - Função funcionamento automático do equipamento.
- **F6** - Função Seleção ° F.



Ligação do equipamento

Premir a tecla **On/off**  do painel de controlo ou do comando. O equipamento arranca sempre na Função **F4** (Função Automática). Para mudar de função deve manter premida continuamente **On/Off**  do painel de controlo; irão aparecendo as diferentes funções no visor; soltar ao obter a função pretendida. Na primeira colocação em funcionamento o equipamento será iniciado com os parâmetros estabelecidos de fábrica.

Função **F0** - Funcionamento Manual

Ao seleccionar **F0** no visor é mostrada a temperatura seleccionada e permite ao utilizador escolher a temperatura de conforto que aparecerá no visor, de 15 °C a 27 °C ou 59 °F a 71 °F, bem como variar a velocidade do soprador do equipamento (5 velocidades assinaladas com as siglas **W1** a **W5**).





A temperatura de conforto é controlada premindo as teclas   do painel de controlo ou   do comando.

As velocidades do soprador serão controladas mantendo premidas as teclas   ou do painel de controlo, ou a partir de  do comando, aparecendo no visor as siglas **W1**, **W2**, **W3**, **W4**, **W5**. Quando o equipamento estiver em funcionamento aparecerão no visor os graus seleccionados.





Função **F1** - Função termómetro digital

Ao seleccionar esta função será indicada no seu visor a temperatura interior da cabina.

Função F2 - Função programadora de tempo





F2 programa o **equipamento** para a sua desligação automática num período entre 1 e 9 horas. Para programar manter premida a tecla **On/Off**  até visualizar no visor F2, seleccionar o tempo de funcionamento com as teclas   e confirmar premindo **On/Off** .

Função F4 - Funcionamento automático do equipamento

Ao seleccionar F4, o utilizador pode escolher a temperatura de conforto 15 °C a 27 °C, ou 59 °F a 71 °F, que seleccionará a partir das teclas   do painel de controlo ou das teclas   do comando. Ao seleccionar aparecerá no visor intercalados  e os graus seleccionados. Com esta função, o equipamento regula e controla automaticamente a temperatura de conforto, atuando sobre as velocidades do ventilador e os compressores.

Pressionando a tecla  do comando à distância anula-se a função F4 e passa para F0 (Função Manual).

Função F5 - Seleção °F

Para ativar esta função deve manter premida a tecla **On/off**  até aparecer no visor F5; até aparecer no visor  do painel de comandos com o equipamento desligado, aparecerá no visor  a piscar; quando ficar fixo premir a tecla  do painel de comando. Ao realizar esta operação o comando é desativado, pelo que ao terminar deve ativar o comando.

Esquema elétrico

AVISO IMPORTANTE!

Precaução de não inverter as polaridades ao ligar o equipamento à bateria. Se isto acontecer, a placa não se acende e o equipamento não funciona.

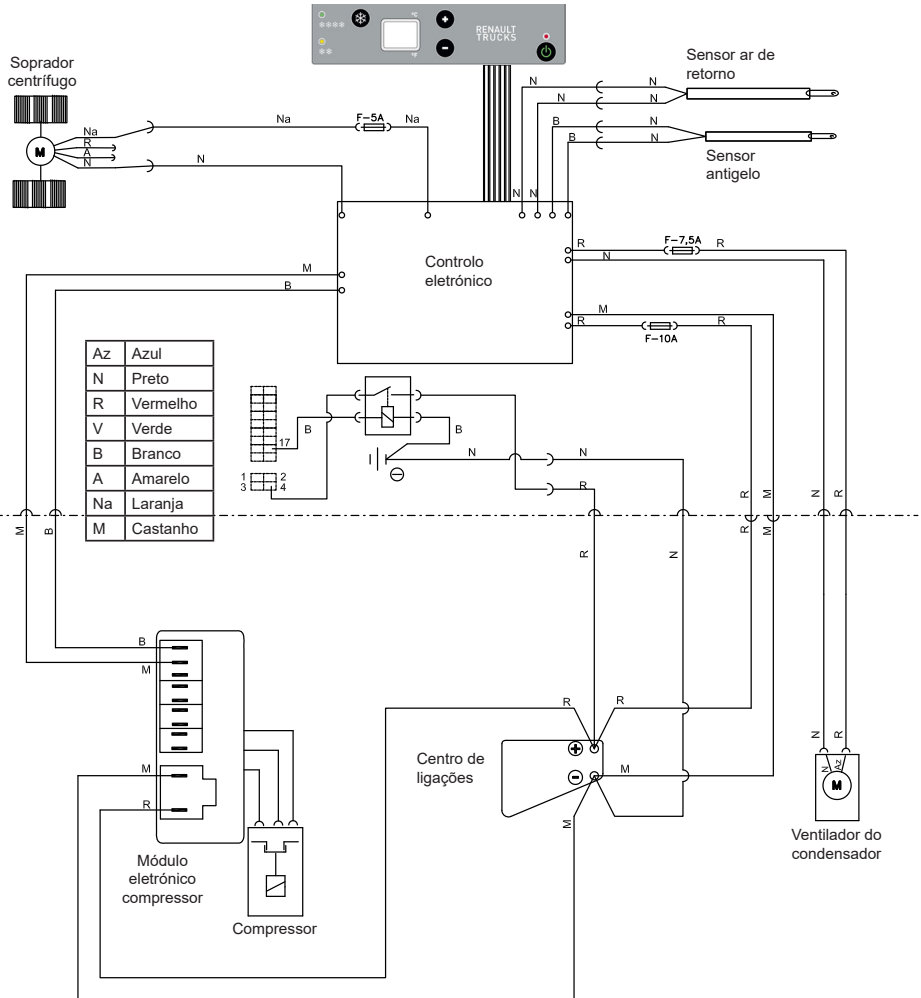

Para limpar o condensador (*) é necessário desmontar a tampa superior do equipamento (8 parafusos rosca chapa) e soprar o condensador com ar de pressão. É recomendável que esta operação seja realizada por um serviço autorizado pela **dirna Bergstrom**.

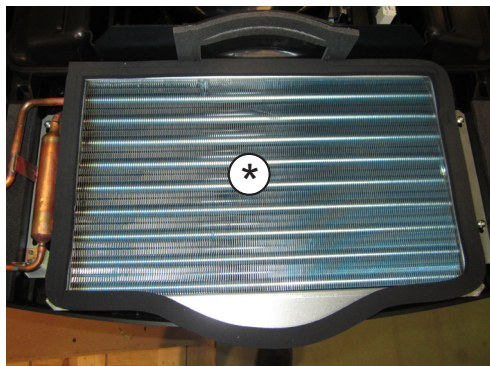

Francisco Alonso, 6
28806 Alcalá de Henares - Madrid
ESPAÑA

C

Contact	Phone	Fax	E-mail
Sales (Ventas Internacional)	+34 918770510	+34 918771158	sales@dirna.bergstrominc.com
Comercial Nacional	+34 918775841	+34 918836321	ventas@dirna.bergstrominc.com
Orders & deliveries (Logística internacional)	+34 918775846	+34 918771158	export@dirna.bergstrominc.com
Orders & deliveries (Logística nacional)	+34 918775840	+34 918836321	comercial@dirna.bergstrominc.com
Technical assistance (Internacional)	+49 51186679681	+49 51186679710	technicalassistance@dirna.bergstrominc.com
Technical assistance (Nacional)	+34 918775845	+34 918836321	oblanco@dirna.bergstrominc.com

www.dirna.com

ES	<p>Dirna Bergstrom, s.l. es titular de todos los derechos de la presente información. La presente información es confidencial y queda prohibido cualquier acto de reproducción, distribución, comunicación pública y/o transformación de cualquier elemento de la misma sin la previa y expresa autorización de dirna Bergstrom, s.l. Esta información ha de ser utilizada única y exclusivamente para el fin para el que fue creada, no siendo dirna Bergstrom, s.l. responsable de los posibles daños que se pudiera causar al cliente y/o a terceras partes por un incorrecto y/o inadecuado uso de la misma. Para cualquier aclaración al respecto pueden dirigirse al Centro de Comunicaciones del fabricante dirna Bergstrom, s.l.</p>
EN	<p>Dirna Bergstrom, s.l. (Hereinafter DIRNA) is the holder of all the rights of this information. This information is confidential and it is absolutely forbidden any act of reproduction, distribution, public communication and/or transformation of any element of it without the previous and express authorization of dirna Bergstrom, s.l. This information must be used only and exclusively for what it has been created, dirna Bergstrom, s.l. doesn't assume any responsibility of possible damages that could be caused to the client and/or third parties for a wrong and/or inadequate use of it. For any doubt about the aforementioned please contact dirna Bergstrom, s.l. by Communication Centre.</p>
FR	<p>Dirna Bergstrom, s.l. est titulaire de tous les droits de la présente information. La présente information est confidentielle et tout acte de reproduction, distribution, communication publique et/ou transformation de tout élément lié à cette information est interdit sans l'autorisation préalable et expresse de dirna Bergstrom, s.l. Cette information doit être utilisée uniquement et exclusivement dans le but pour lequel elle a été créée, dirna Bergstrom, s.l. n'étant pas responsable d'éventuels dommages pouvant affecter les clients et/ou des tierces personnes dus à une utilisation incorrecte et/ou inadéquate de cette information. Pour toute clarification à ce sujet, veuillez vous adresser au Centre de Communications du fabricant dirna Bergstrom, s.l.</p>
DE	<p>Dirna Bergstrom, s.l. Ist der Inhaber dieser Information. Der Inhalt dieser Information ist vertraulich, und die Vervielfältigung, Verteilung, Veröffentlichung bzw. Abänderung von Teilen daran ohne vorherige und schriftliche Genehmigung durch dirna Bergstrom, s.l. ist untersagt. Diese Information darf nur für jenen Zweck verwendet werden, für den sie geschaffen wurde, und dirna Bergstrom, s.l. haftet nicht für die möglichen Schäden, die dem Kunden und/oder Dritten durch eine falsche oder ungeeignete Anwendung dieser Information entstehen könnte. Weitere Informationen hierzu erhalten Sie von der Kommunikationszentrale des Herstellers dirna Bergstrom, s.l.</p>
IT	<p>Dirna Bergstrom, s.l. è titolare di tutti i diritti della presente informazione. La presente informazione è confidenziale ed è vietata qualsiasi forma di riproduzione, distribuzione, comunicazione pubblica e/o trasformazione di qualsiasi elemento della stessa senza la previa ed espresa autorizzazione di dirna Bergstrom, s.l. Questa informazione deve essere usata unicamente ed esclusivamente per la finalità creata. dirna Bergstrom, s.l. declina qualsiasi responsabilità dai possibili danni causati al cliente e/o a terzi da un non corretto e/o inadeguato uso della stessa. Per qualsiasi chiarimento al rispetto rivolgersi al Centro delle Comunicazioni del fabbricante dirna Bergstrom, s.l.</p>