

**bycool!**  
green line

**COMPACT 1.4**

**RENAULT T High sleeper cab**



**Instrucciones de Montaje**

*Mounting Instructions*

**Instructions de Montage**

*Montageanweisungen*

**Istruzioni di Montaggio**

**ES** Spanish

**EN** English

**FR** French

**GE** German

**IT** Italian

### Recomendaciones Para el montaje

- Antes de iniciar el montaje leer las instrucciones y seguirlas durante el proceso de instalación.
- Usar las herramientas adecuadas para cada operación.

### Electricidad

- Desconectar la llave de contacto.
- Desconectar la batería antes de empezar el montaje.
- Asegurar el conexionado de los componentes eléctricos, verificando su correcto encaje.

### Atención

Si durante el montaje el equipo se inclina ó se abate la cabina con el equipo montado, se deberá esperar un mínimo de 60 minutos, desde que el equipo quede horizontal, antes de ponerlo en marcha.

### Atención

Al instalar el equipo de aire acondicionado en el techo se debe proteger la parte superior de la cabina con un paño ó manta protectora para evitar posibles arañazos. Al instalar **Compact** en el techo hay que tener en cuenta que, normalmente, las cabinas que vienen provistas de escotilla, tienen una estructura suficiente para soportar el peso del equipo. Sin embargo, cuando no ocurra así y sea necesario realizar corte en el techo ó incluso si en el caso de llevar escotilla el material no es lo suficientemente resistente (caso de techo de fibra, plástico, etc...) es el instalador el que debe decidir, **bajo su responsabilidad**, sobre la necesidad de reforzar el techo para evitar posibles deformaciones, roturas, entradas de agua, etc... habilitando los medios para que esto no ocurra.

### Herramientas

Juego de Llaves Torx

Juego de Llaves Allen

Llave fija 10, 13, 14

Tijeras

Flexómetro

### Documentación incluida

Instrucciones de montaje	1001262644
Manual del usuario	1001284900
Diagnosis de averías	1001284902
Garantía	220AA10017

### Simbología



Fragil





Atención corte!



Riesgo eléctrico

### Advertencias

 El personal instalador debe poseer una formación suficiente en Aire Acondicionado de vehículos.

 **dirna Bergstrom, s.l.** queda exenta de responsabilidad si se producen averías que procedan de una inadecuada manipulación ó instalación del equipo, ó por modificaciones y sustituciones efectuadas sin nuestra expresa autorización por escrito.

 **Equipo precargado con gas** refrigerante R-134a. (**No manipular el circuito de gas refrigerante**).

 Véase **procedimiento de garantía** del producto incluido en **Diagnosis de Averías**.

 Véase **Manual de Usuario** del equipo para el correcto funcionamiento del mando a distancia y del panel de control.

 Al finalizar la instalación se debe entregar al usuario: **Manual del Usuario, Garantía y Diagnosis de averías**.



Antes de empezar con el montaje, montar rejilla entrada aire delantera.



1

Desmontar consola original, tirando del externo de las luces para acceder a los tornillos de fijación.  
En el caso de llevar leds (\*) desmontar tirando de ellos.



2

Desmontar escotilla quitando tornillos de fijación de la misma (en escotilla eléctrica desconectar clema (\*) de la misma).



**3** Limpiar contorno escotilla y pegar junta EPDM 30x25, por el exterior del resalte del contorno del hueco de la escotilla.



**4** **COMO CORTAR LA JUNTA EPDM PARA EVITAR FILTRACIÓN DE AGUA EN LA CABINA**

A- Pegar la junta, manteniendo 100 mm de papel protector por cada lado.

B- Quitar los dos piezas de papel.

C- Pegue presionado ambos finales.

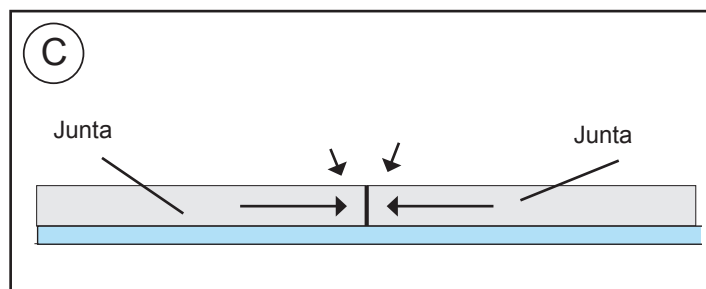
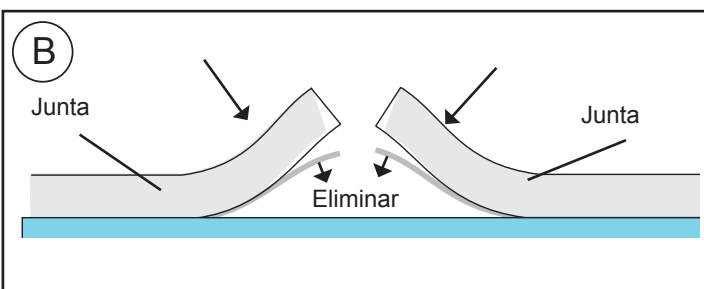
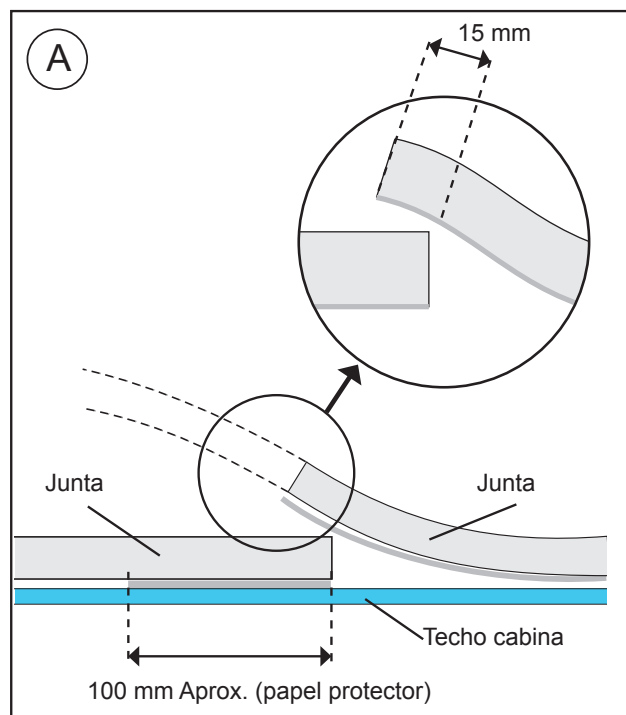



**5** Posicionar equipo sobre hueco escotilla, introduciendo las guías en taladros (\*) de la cabina.



**6** Introducir soportes en espárragos M8, por debajo del tapizado, fijar con (4) arandelas planas Ø 8 y (4) tuercas 8/125 autoblocantes, posicionando éstas en ranuras de los soportes y apretando hasta hacer tope con los hexágonos de la base.

**Atención:** Es muy importante quitar las grapas de sujeción del cableado de escotilla, para que los soportes no aplasten los cables.



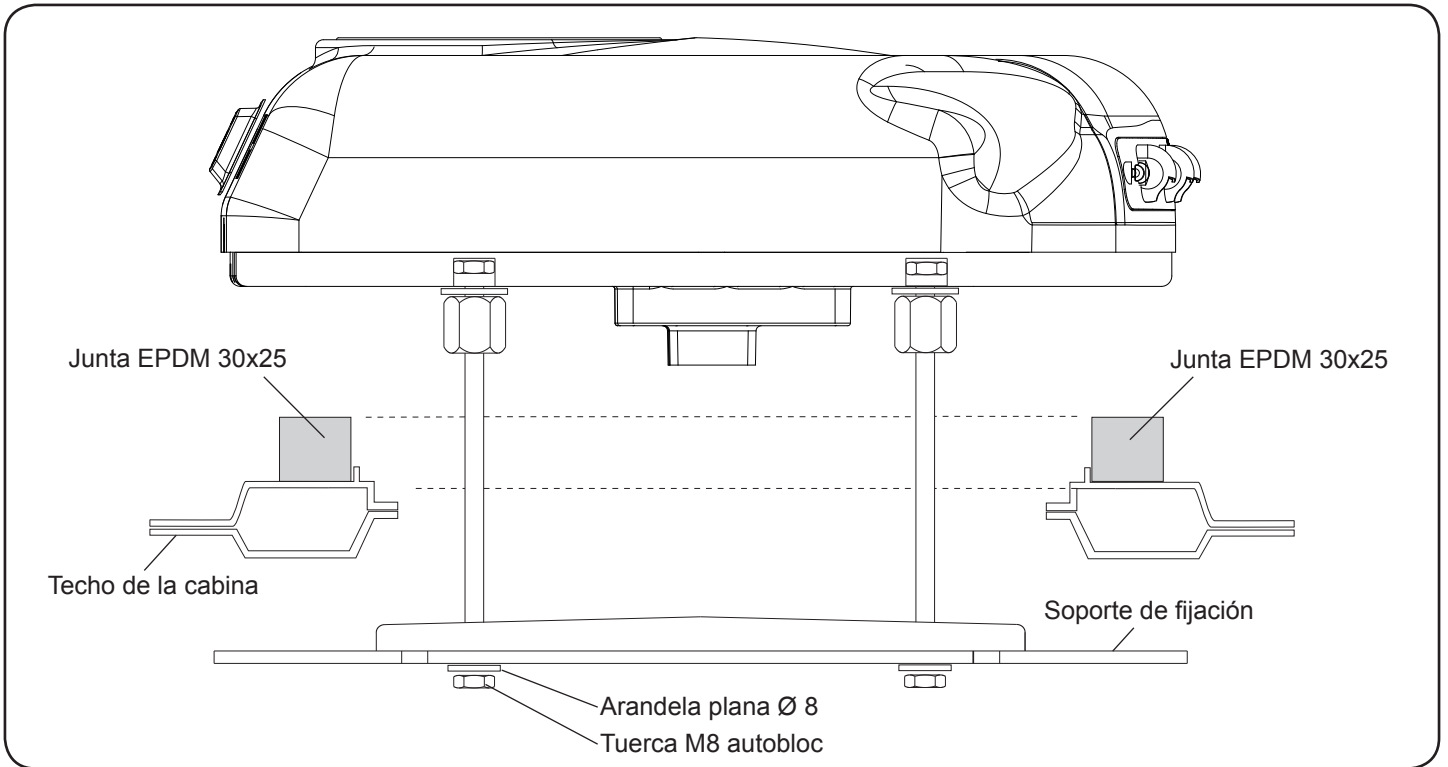

**7** Posicionar consola sobre el panel interior de distribución de aire y fijar con (4) tornillo 6/100x15 con arandela.

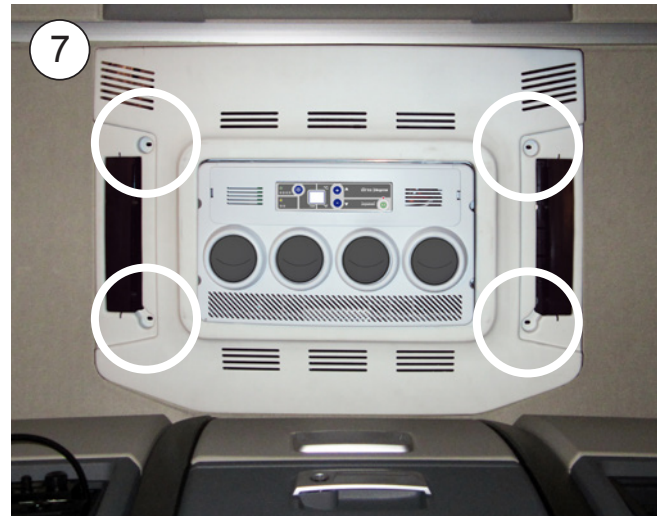

**8** Conectar luces originales e introducir las en la consola presionando sobre ellas.



**9** Pasar cableado de alimentación por debajo del spoiler y conectar con equipo, fijar clemas de conexión al techo con soportes con adhesivo y bridas de plástico.

**Atención: limpiar bien la zona antes de pegar los soportes con adhesivo.**

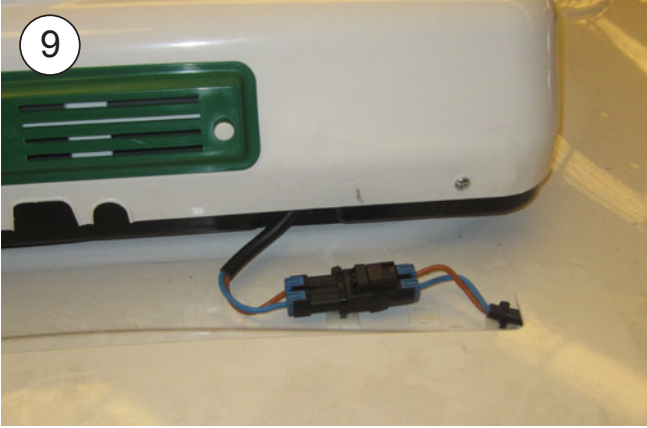
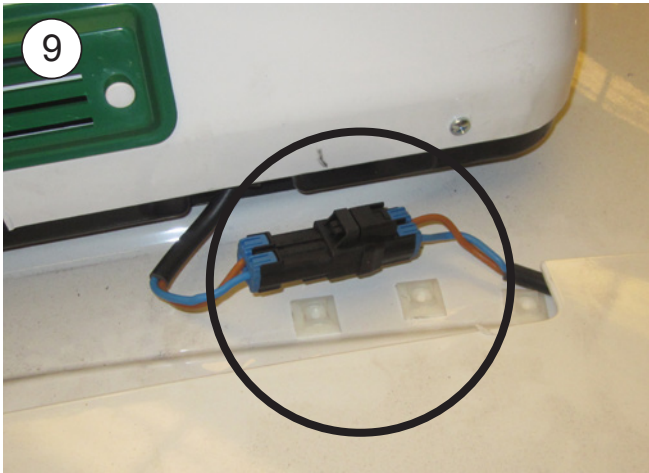

**10** Aflojar soportes de spoiler, lado derecho, y pasar cableado por debajo de ellos, pegado a la esquina de la cabina y dejar soportes spoiler en posición original.





**11** Fijar cableado bajo el spoiler con soportes con adhesivo y bridas de plástico.

**Atención:** limpiar bien la zona antes de pegar los soportes con adhesivo.



**12** Sujetar cableado con soportes con adhesivo y bridas a cabina, soporte spoiler lateral y cableado original.

**Atención:** limpiar bien la zona antes de pegar los soportes con adhesivo.

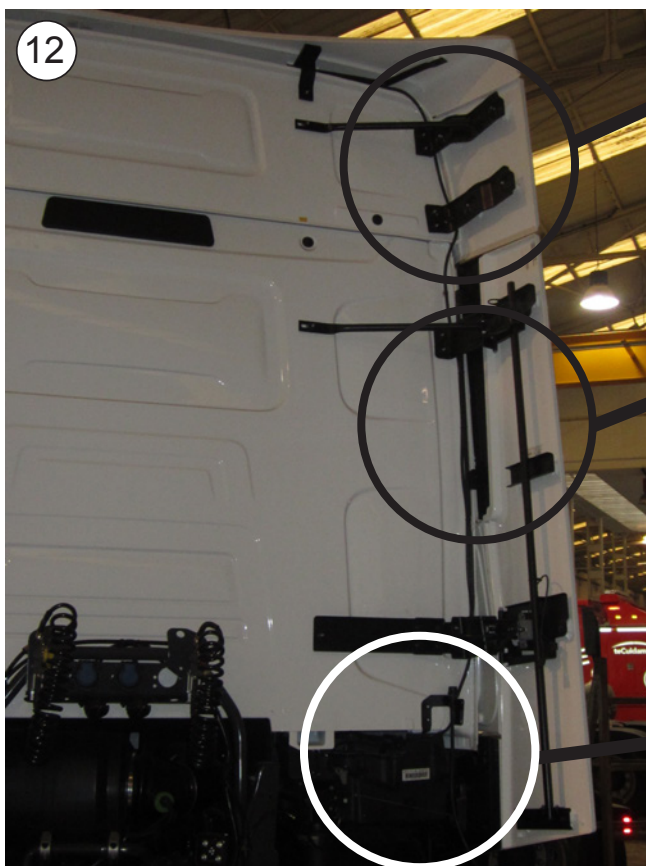
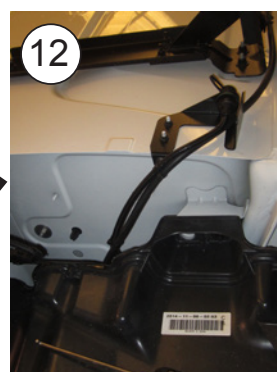
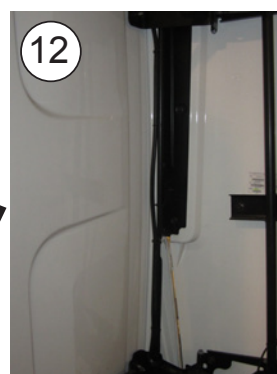



13

Abatir cabina y pasar cableado por debajo de protector (\*) hacia la parte delantera de la cabina, fijándole con bridas a cable original.

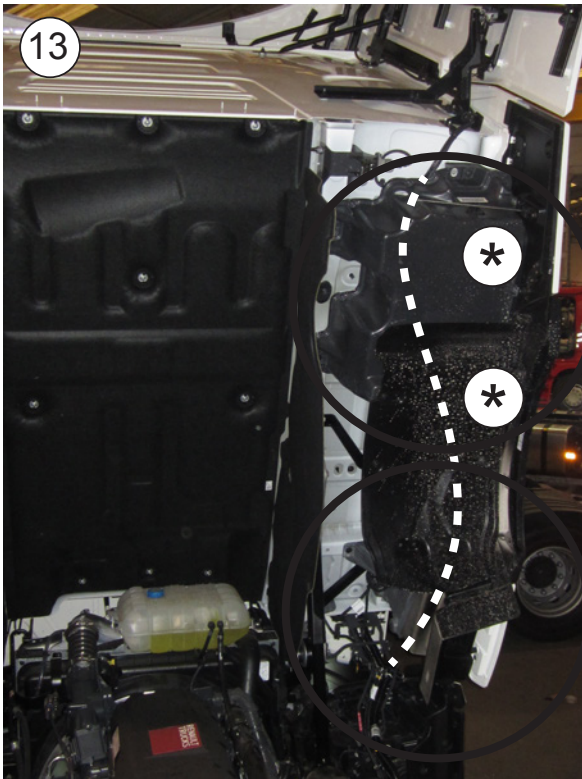

14

Dejar cabina en posición marcha y desmontar tapas de conexiones y paso de cableados originales (\*).

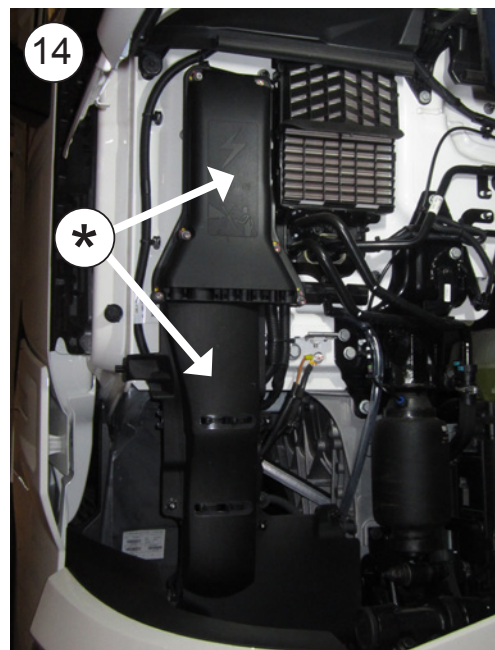

**15** Conectar cableado a tomas originales de (+) y (-) pasándolo con cableados originales. Fijar fusible con brida de plástico a cableado original.

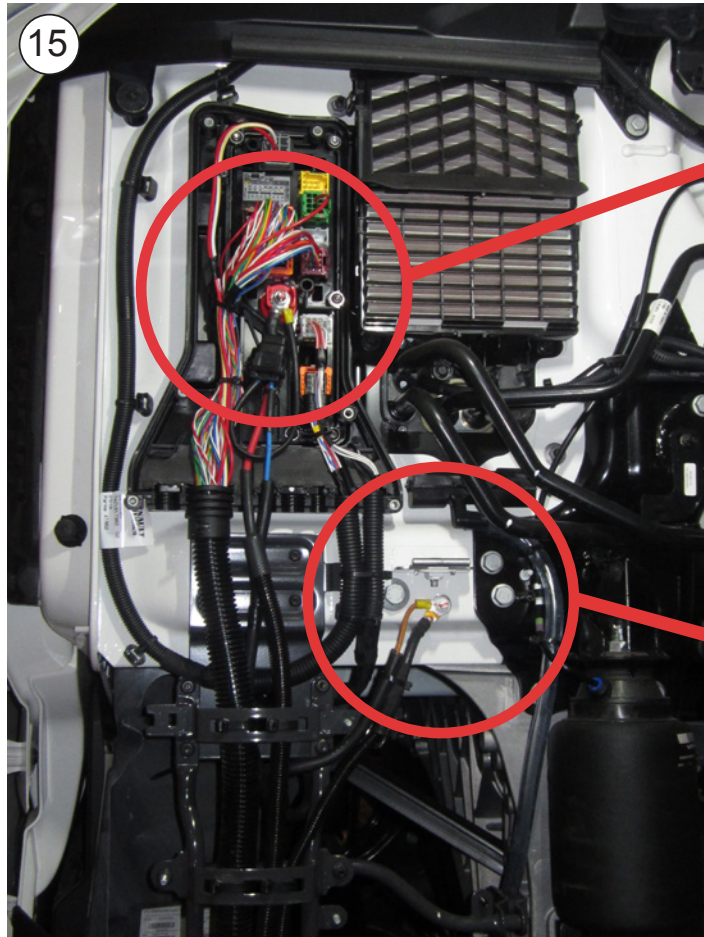
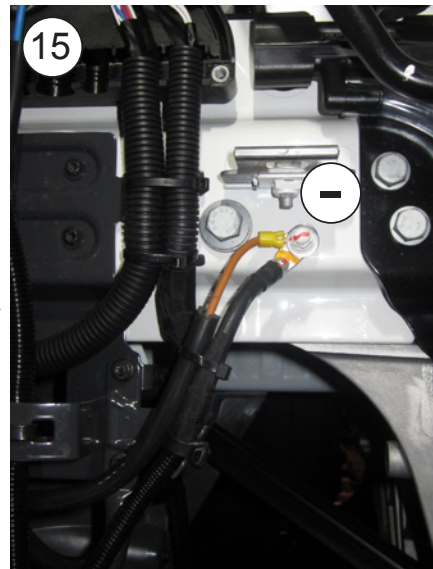
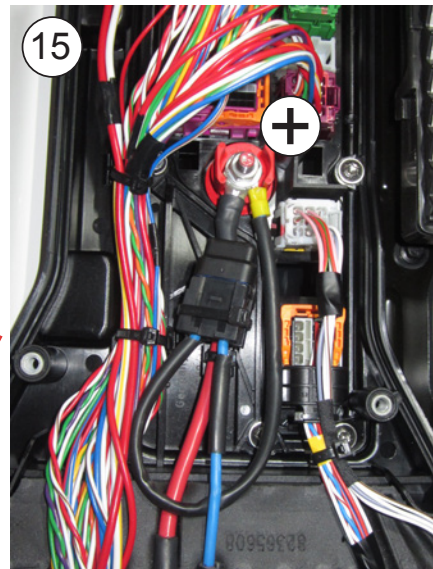

Atención antes de poner el equipo en funcionamiento hay que esperar al menos una hora después de dejar la cabina en posición de marcha.

Esquema eléctrico

¡AVISO IMPORTANTE!

**Precaución** de no invertir las polaridades al conectar el equipo a la batería. Si esto sucediera la placa no se enciende y el equipo no funciona.

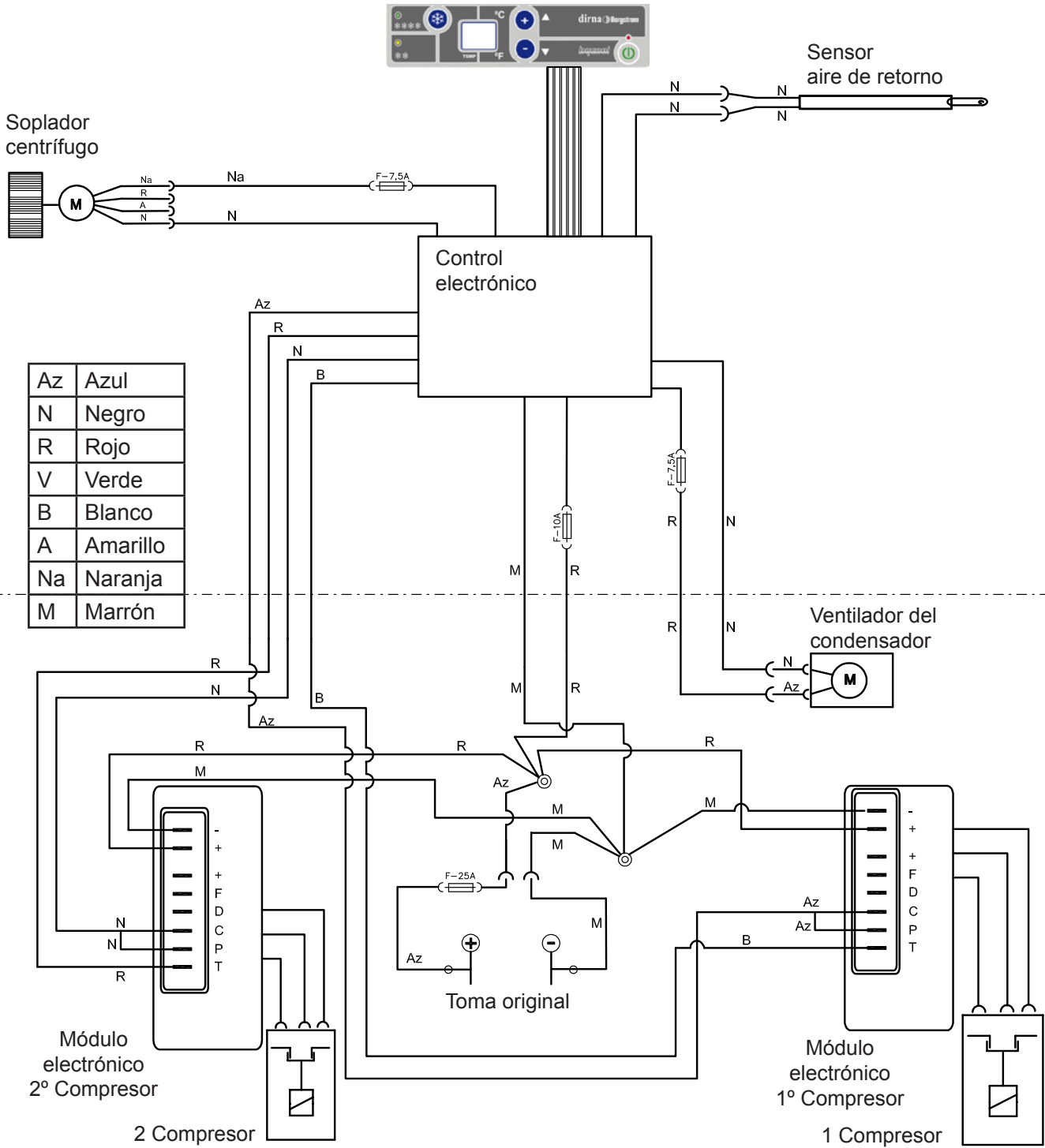



### Assembly Recommendations

- Before starting assembly, please read instructions and follow them during installation process.
- Use the adequate tools for each operation.

### Electricity

- Disconnect ignition key.
- Disconnect battery before starting assembly.
- Make sure electric components are securely connected, checking their correct fitting.

### Warning

**If the unit slants during assembly, wait for at least 60 minutes with the unit in horizontal position before starting it up.**

### Warning

When installing air conditioning equipment on roof, the upper cabin part must be protected with a cloth or a protective blanket to avoid possible scratches. When installing **Compact** on roof, take into account that, normally, cabins equipped with a hatch have a strong enough structure to hold equipment weight. However, if it is not the case and it is necessary to carry out a cut in the roof or, although it has a hatch, the material is not resistant enough (*if roof is made of fibre, plastic, etc...*), it is the installer who will have to decide, under his responsibility, if it is necessary to reinforce the roof to avoid possible deformations, breaks, water entries, etc., habilitating the means required to stop it from occurring.



### Tools

- Torx wrenches set
- Allen wrenches set
- Open-jawed spanner 10, 13, 14
- Scissors
- Flexo-meter







### Documentation included

Mounting instructions	1001262644
User's guide	1001284900
Troubleshooting	1001284902
Warranty	220AA10017

### Symbology

-  Fragile
-  Beware of cuts!
-  Electrical hazard

### Warnings

-  The installing personnel must have a sufficient training in vehicles air conditioning.
-  **dirna Bergstrom, s.l.** shall not be responsible for breakdowns or damages coming from an inadequate handling or installation of the equipment or from modifications and substitutions carried out without our express and written authorisation.
-  **Equipment pre-charged with refrigerating gas, R-134a. (Do not handle refrigerating gas circuit).**
-  Please see product **warranty procedure** included in **Troubleshooting diagnosis**.
-  Please see equipment **User's Guide** for its correct functioning of the remote control and control panel.
-  Once installation is finished, the following documents must be handed over to the user: **User's Guide, Warranty and Troubleshooting Diagnosis**.

 Mount the front air input grille before starting assembly.



**1** Take down the original console, pulling on the end of the lights to access the fastening screws.  
If LEDs are fitted (\*), pull on them to remove.



**2** Take down the hatch by removing the fastening screws (disconnect wire clamp (\*) in electrical hatch).



**3** Clean the hatch surround and attach 30x25 EPDM seal on the outside of the ridge of the hatch gap.



**4** **HOW TO CUT EPDM GASKET TO AVOID WATER FILTRATION INTO THE CABIN**

**A-** Glue gasket, keeping 100 mm of protection paper at each side.

**B-** Remove the two pieces of paper.

**C-** Glue by pressing both ends.

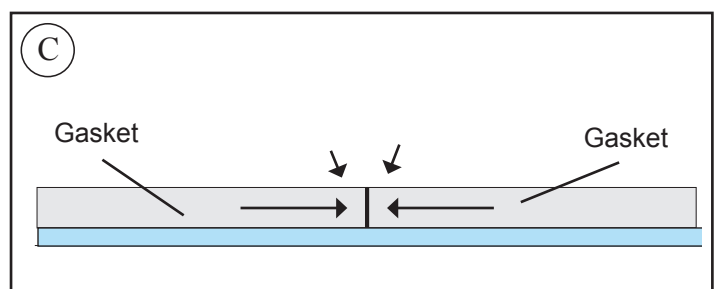
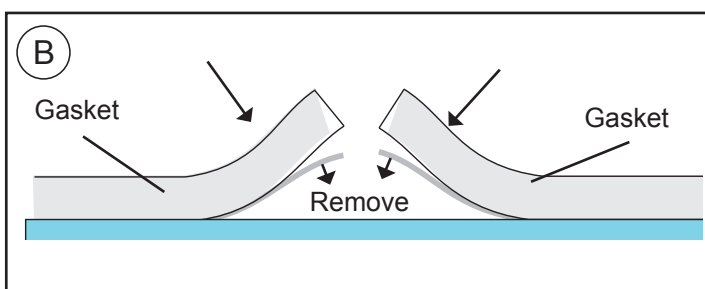
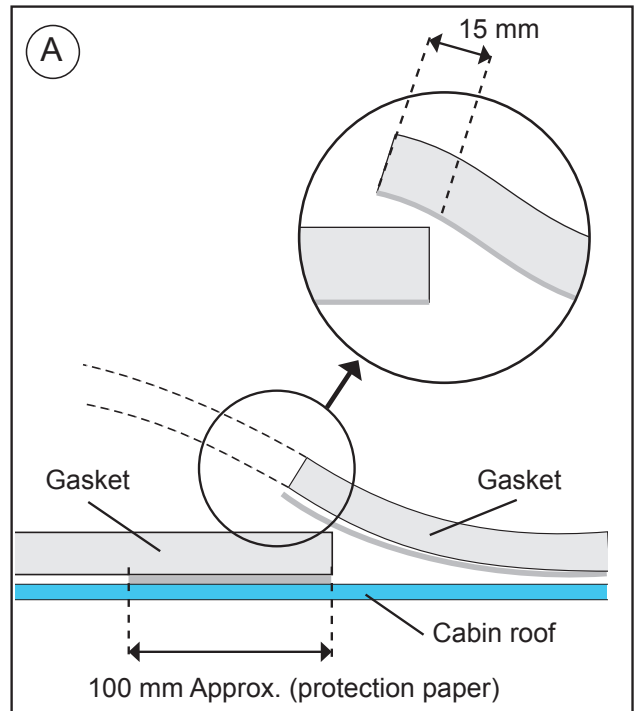



**5** Position the unit on the hatch gap, introducing the guides in the boreholes (\*) of the cabin.



**6** Introduce the mounts on M8 studs, underneath the upholstery, secure with (4) Ø8 flat washers and (4) 8/125 self-locking nuts, positioning them in the grooves of the mounts and tightening until they come up against the base hexagons.

**Caution:** It is very important to remove the hatch wiring clamps to ensure the wiring is not crushed by the mounts.



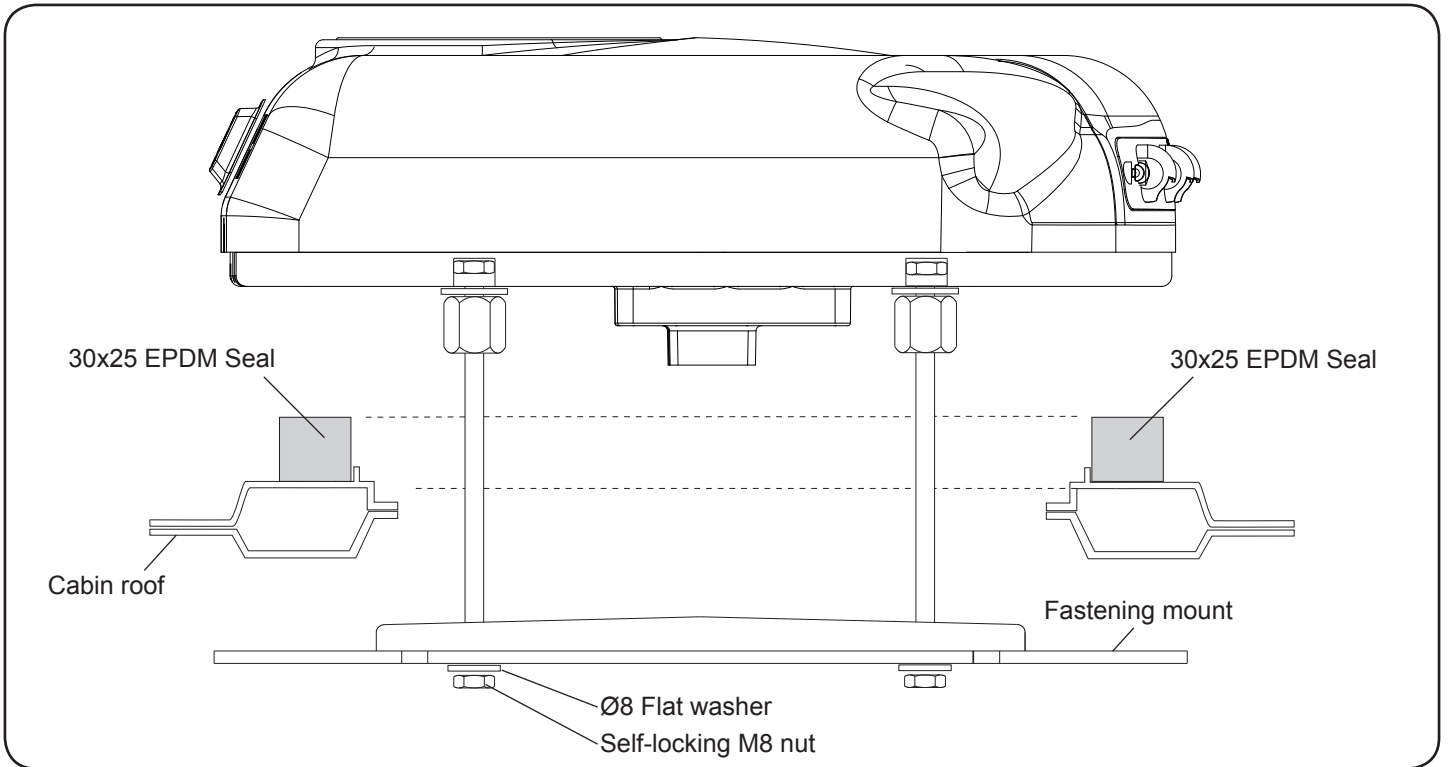

**7** Position console on inner air distribution panel and secure with (4) screws 6 / 100x15 with washer



**8** Connect the original lights and introduce them in the console by pressing on them.



**9** Pass the power cable underneath the spoiler and connect to the unit, secure the connection wire clamps to the roof with mounts with adhesive and plastic flanges.

**Caution: clean the area thoroughly before attaching the mounts with adhesive.**

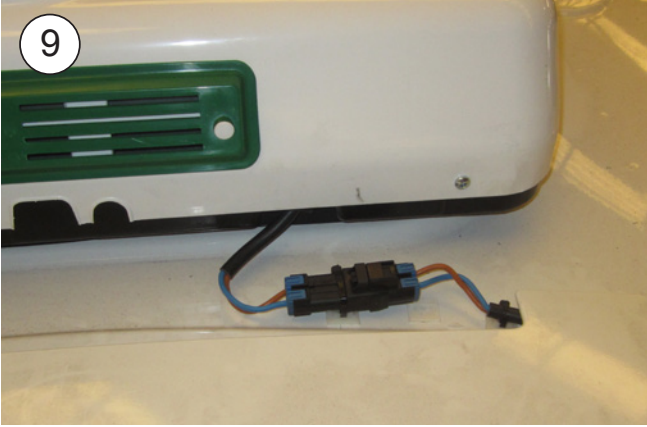
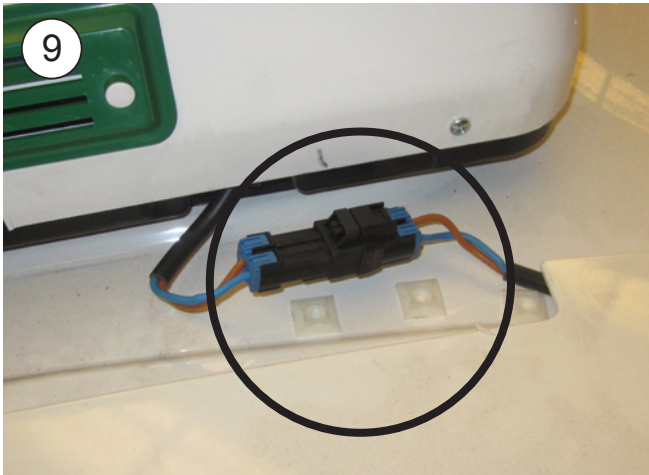

**10** Loosen the right side spoiler mounts and pass the wiring underneath, next to the corner of the cabin, and leave the spoiler mounts in original position.





**11** Secure the wiring underneath the spoiler with the mounts, with adhesive and plastic flanges.

**Caution: clean the area thoroughly before attaching the mounts with adhesive.**



**12** Secure the wiring with mounts with adhesive and flanges to the cabin, side spoiler mount and original wiring.

**Caution: clean the area thoroughly before attaching the mounts with adhesive.**

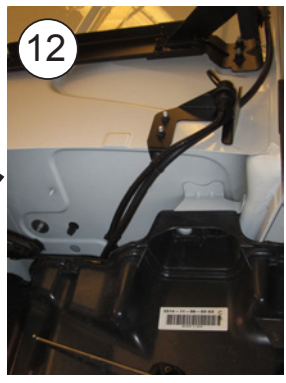
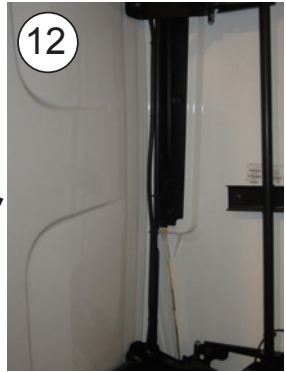

**13** Tilt the cabin and run the wiring underneath the protector (\*) to the front part of the cabin, securing to the original wires with flanges.

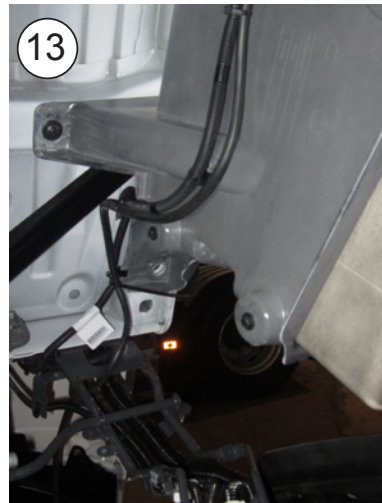
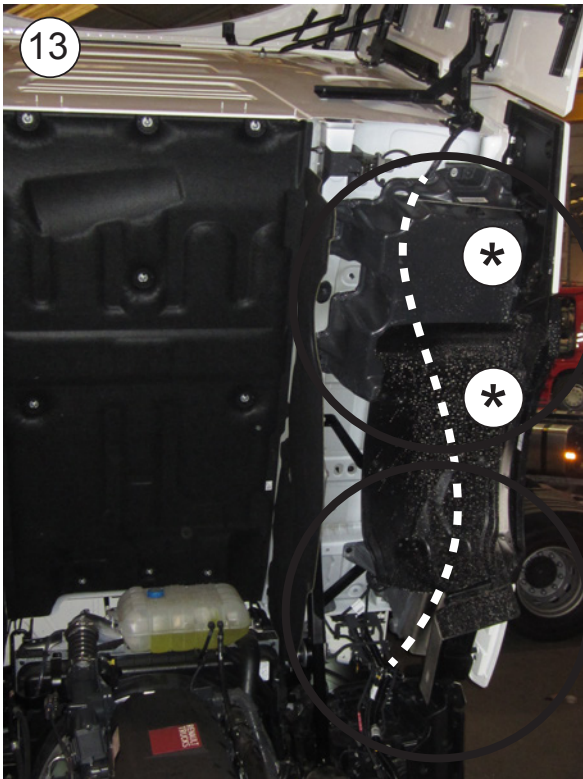

**14** Leave the cabin in operating position and take down the original wiring run and connections covers (\*).

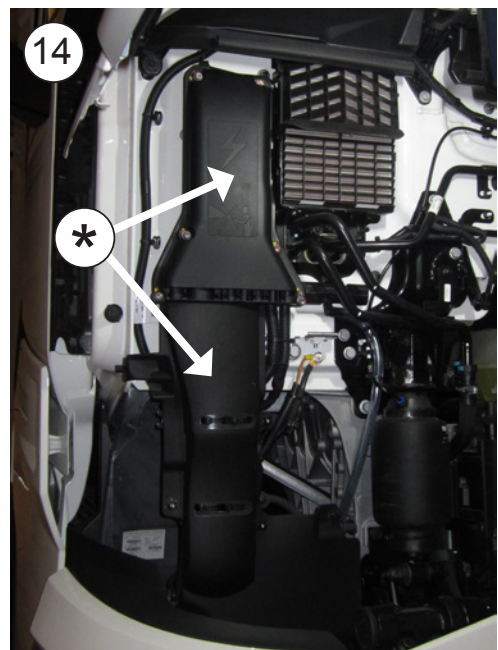



15

Connect the wires to the original (+) and (-) connection points, passing them with the original wiring. Secure the fuse to the original wiring using plastic flanges.

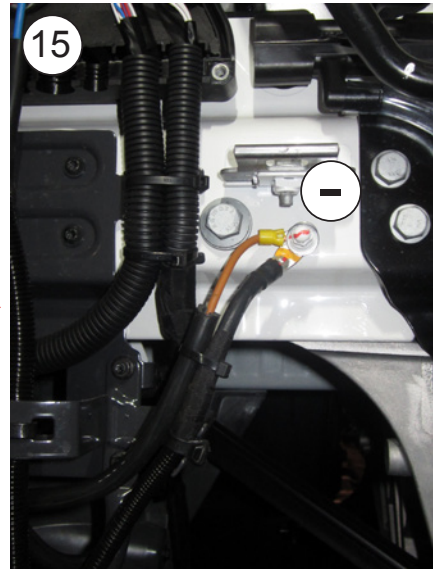
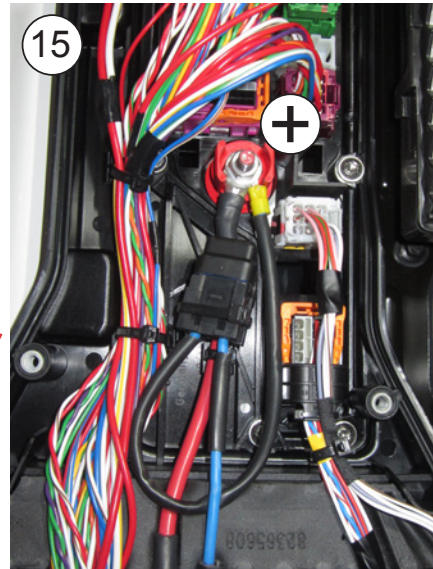
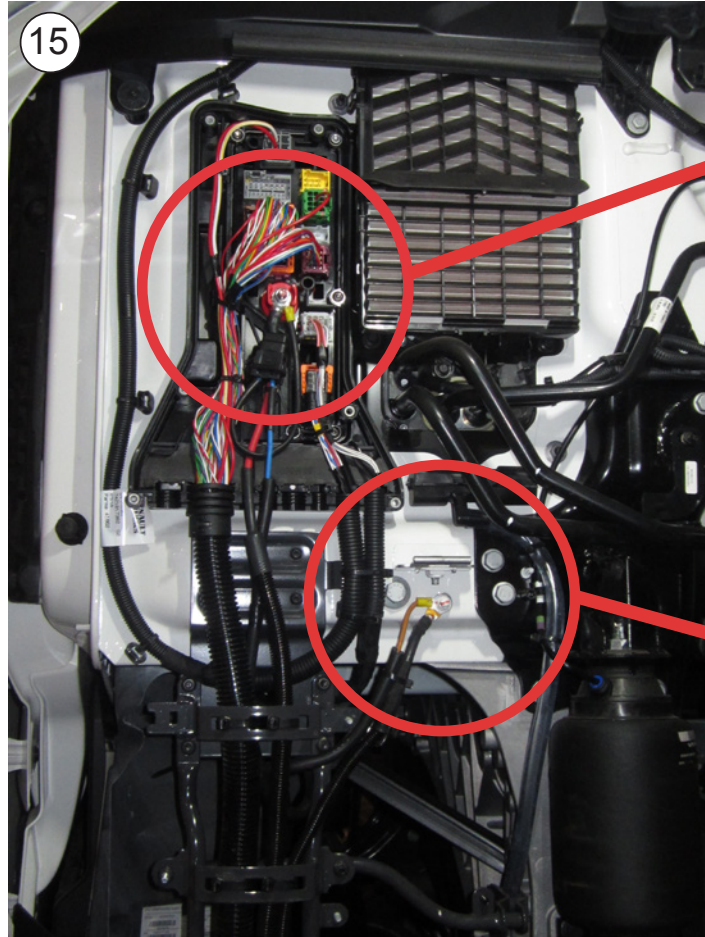

**Caution:** The unit must not be started up until at least one hour after leaving the cabin in operating position.



Electric wiring

**IMPORTANT WARNING!**

**Take care** not to invert polarities when connecting the unit to the power supply. If this happens, the plate does not come on and the unit does not work.

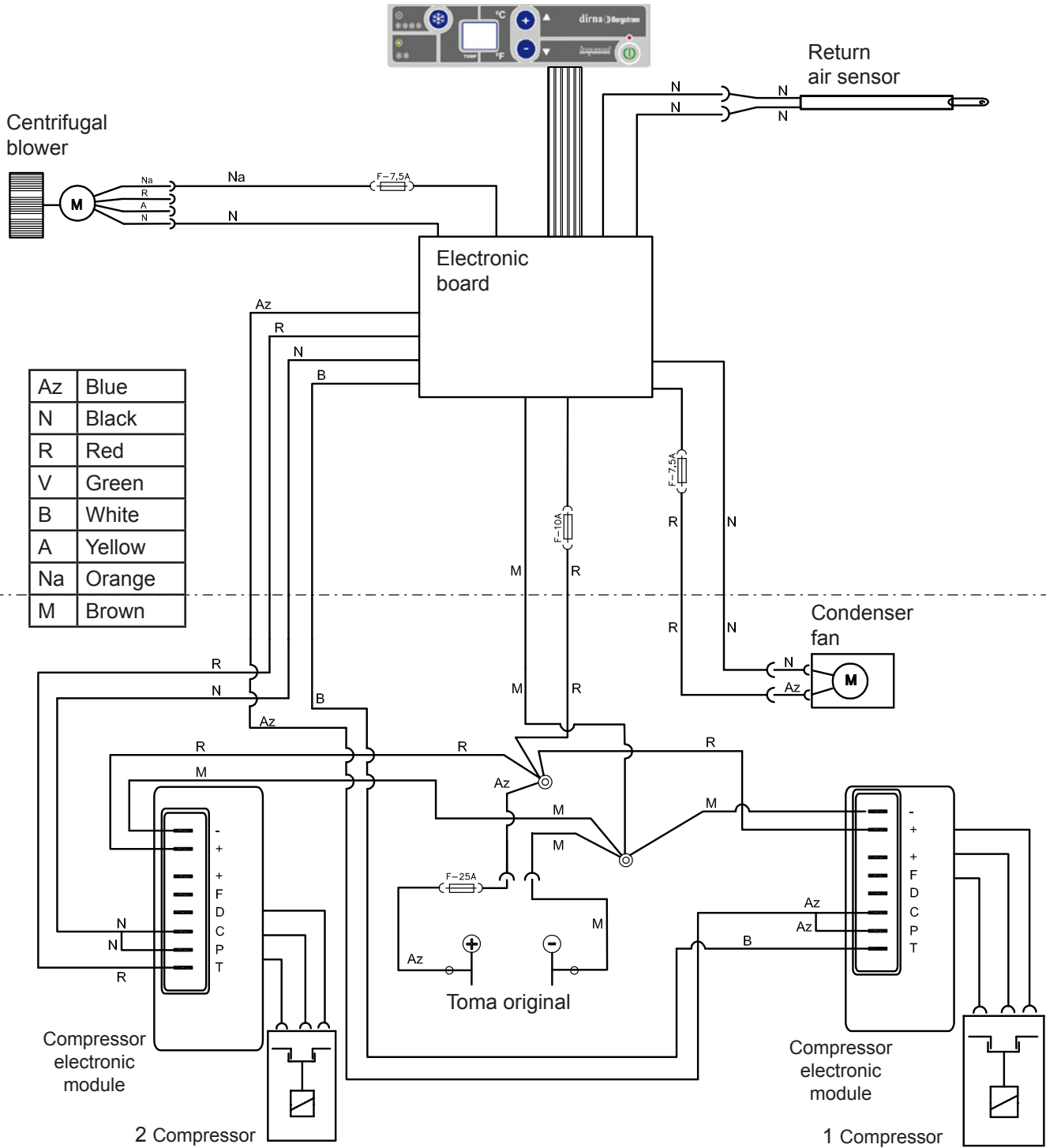

## Recommandations Pour Le Montage

- Avant de commencer le montage de l'appareil, prière de lire les instructions et de les suivre attentivement.
- Utiliser les outils convenant à chaque opération.

### Electricity

- Déconnecter la clé de contact.
- Déconnecter la batterie avant de commencer le montage.
- Vérifier le câblage des composants électriques et leur correcte installation.

### Attention

Si pendant le montage l'équipement est incliné, il faudra attendre au moins 60 minutes avant de le mettre en marche une fois qu'il aura été remis sur sa position horizontale.

### Attention

Lors de l'installation de l'appareil d'air conditionné sur le toit, il faudra protéger la partie supérieure de la cabine avec un linge ou une couverture de protection afin d'éviter les éventuelles égratignures.

Durant l'installation du **Compact**, tenir compte du fait que normalement les cabines pourvues d'écouille possède une structure suffisamment solide pour supporter le poids de l'appareil. Cependant, si ce n'est pas le cas et qu'il est nécessaire de découper le toit ou même si disposant d'écouille, la structure n'est pas suffisamment rigide (si elle était en fibre, plastique, etc.) il appartiendra à l'installateur de décider s'il faut renforcer le toit pour éviter toute déformation, rupture ou voie d'eau, etc., et prendre les mesures nécessaires à cet effet.

## Outils

Jeu de clés Torx  
 Jeu de clés Allen  
 Clé fixe 10, 13, 14  
 Ciseaux  
 Mètre

## Documentation included

Instructions de montage	1001262644
Guide de l'utilisateur	1001284900
Solution des problèmes	1001284902
Garantie	220AA10017

## Symbologie



Fragile









Attention aux coupures !



Risque électrique

### Garantie

-  L'installateur devra posséder la formation pertinente en air conditionné sur véhicules.
-  **dirna Bergstrom, s.l.**, ne sera pas responsable des dommages ou des bris dérivés d'une installation ou d'une manipulation incorrecte ni des modifications réalisées sans autorisation expresse par écrit.
-  **Appareil pré-chargé de gaz réfrigérant R-134. (Ne pas manipuler le circuit de gaz réfrigérant).**
-  Voir la **procédure de garantie** du produit au **Diagnostic de problèmes**.
-  Voir le **Guide de l'Usager** de l'appareil pour le fonctionnement correcte de la télécommande et du tableau de commande.
-  Après l'installation, vous devez fournir à l'utilisateur: **Manuel d'utilisation, garantie et diagnostic de pannes**.

 Avant de commencer le montage, monter la grille d'entrée d'air avant.



**1** Démontez la console d'origine et tirez sur l'extrémité des lumières pour accéder aux vis de fixation.  
Si des leds sont installés (\*), il faudra les démonter en les tirant.



**2** Démontez ensuite l'écoutille en retirant la vis de fixation de cette dernière (dans une écoutille électrique, déconnecter la borne (\*)).





**3** Nettoyer le contour de l'écouille et coller le joint EPDM 30x25 à l'extérieur du bossage du contour du creux de l'écouille.



**4** **COMMENT COUPER LE JOINT EPDM POUR EVITER LES FILTRATIONS DANS LA CABINE**

**A-** Coller le joint en maintenant une protection en papier de 100 mm de chaque côté.

**B-** Retirer les deux morceaux de papier.

**C-** Coller en faisant pression sur les deux extrémités.

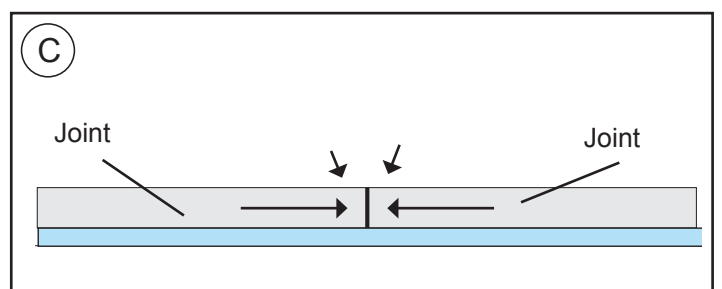
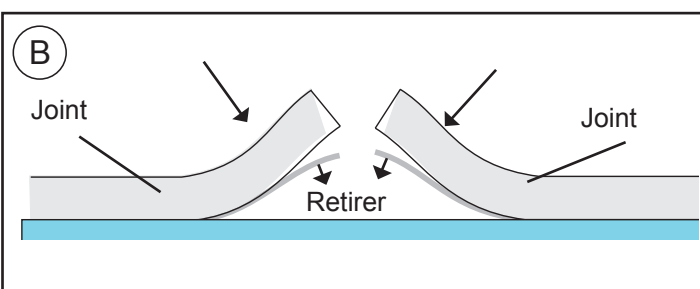
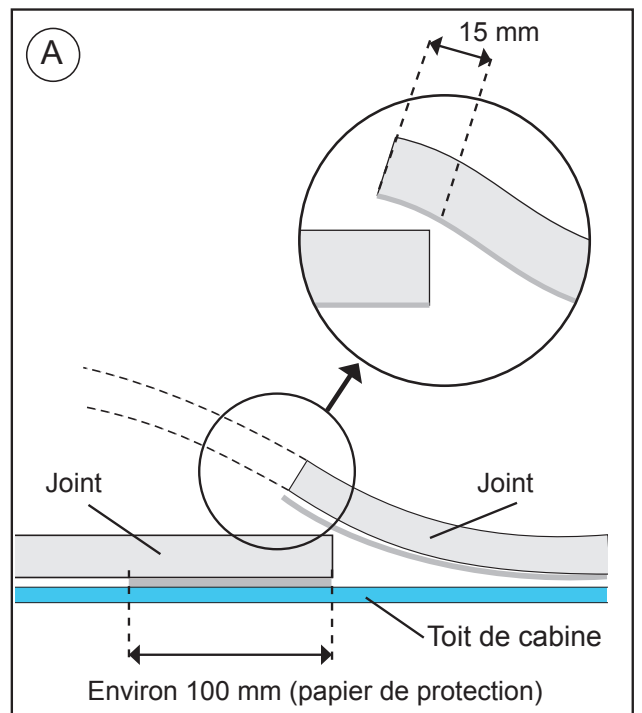

**5** Placer l'équipement sur le creux de l'écouille en introduisant les guides dans les trous (\*) de la cabine.



**6** Introduire les supports dans les goujons filetés M8, sous la tapisserie, fixés avec (4) rondelles plates Ø 8 et (4) écrous 8/125 autobloquants, en les plaçant dans les rainures des supports et en serrant jusqu'à atteindre les hexagones de la base.

**Attention** : il est très important de retirer les agrafes de fixation du câblage de l'écouille pour que les supports n'écrasent pas les câbles.

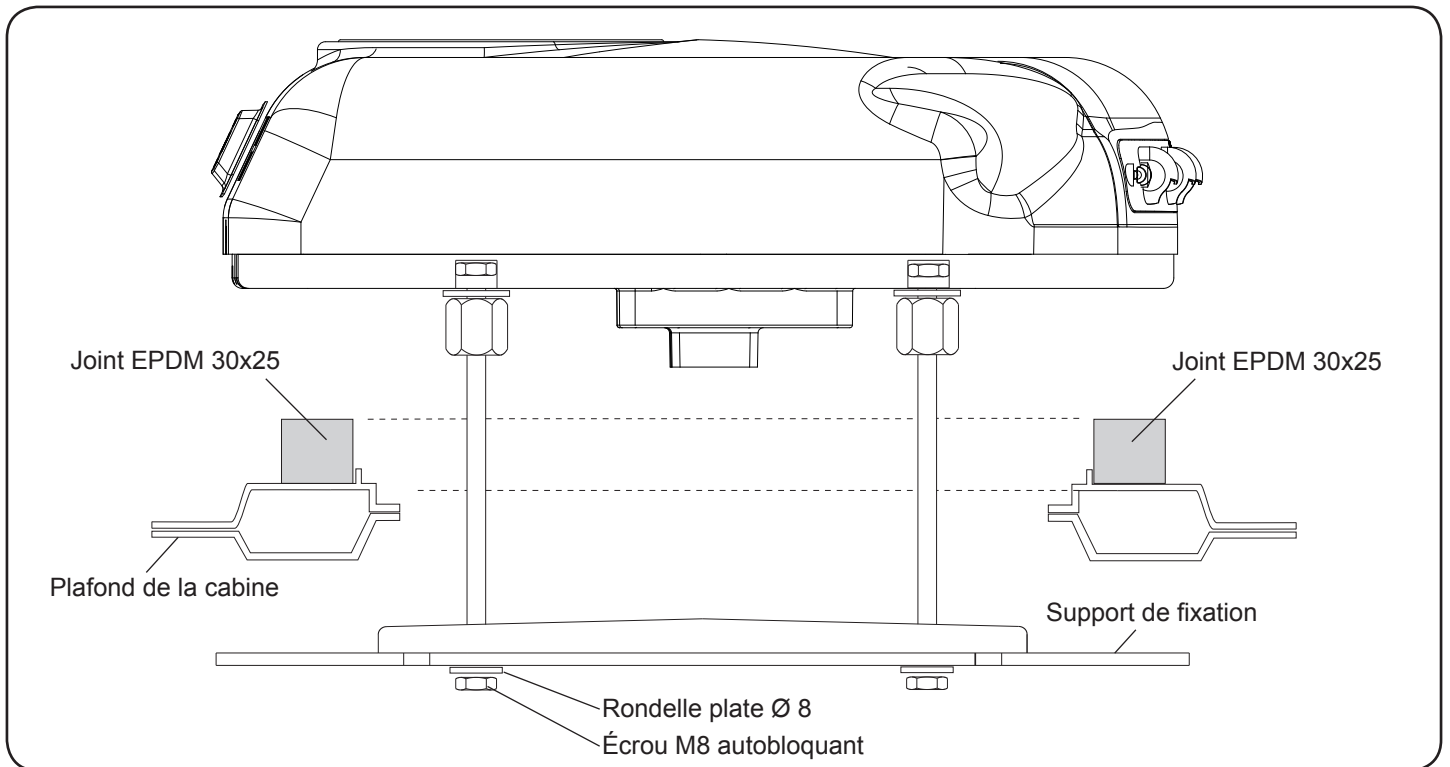

**7**

Placer la console sur le panneau intérieur de distribution d'air et fixer avec (4) vis 6/100x15 avec rondelle.

**8**

Connecter les lumières d'origine et les introduire dans la console en serrant.





**9** Passer le câblage d'alimentation sous le spoiler et connecter à l'équipement. Fixer les broches de connexion au plafond avec des supports et de l'adhésif et des brides en plastique.

**Attention : nettoyer correctement la zone avant de coller les supports avec de l'adhésif.**

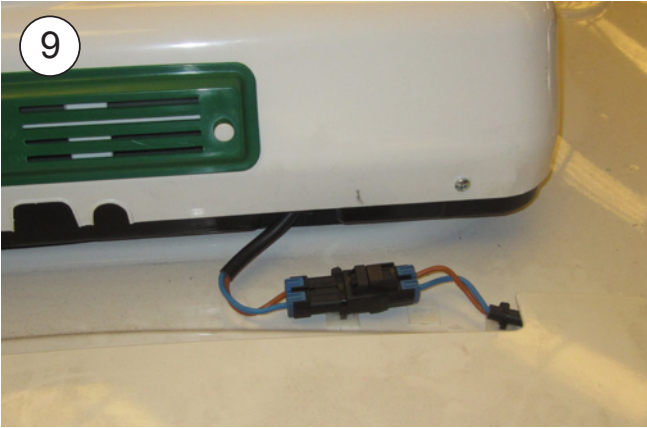
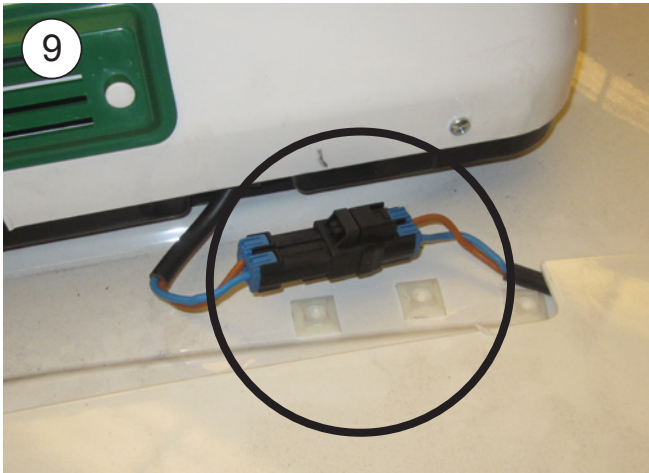

**10** Desserrer les supports du spoiler, côté droit, et passer le câblage sous ces derniers, collé à l'angle de la cabine, puis laisser les supports spoiler sur la position d'origine.



11

Fixer le câblage sous le spoiler avec des supports et de l'adhésif et des brides en plastique.

**Attention : nettoyer correctement la zone avant de coller les supports avec de l'adhésif.**



12

Fixer le câblage avec des supports et de l'adhésif et des brides à la cabine, support spoiler latéral et câblage d'origine.

**Attention : nettoyer correctement la zone avant de coller les supports avec de l'adhésif.**

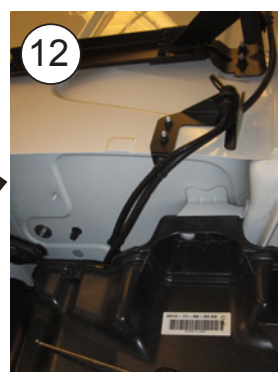
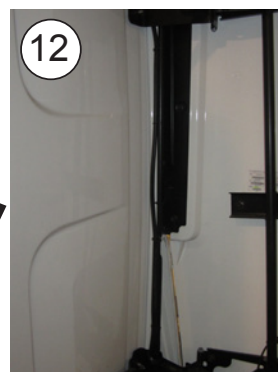

13

Abattre la cabine et passer le câblage sous le protecteur (\*) vers la partie avant de la cabine, en fixant avec des brides au câble d'origine.

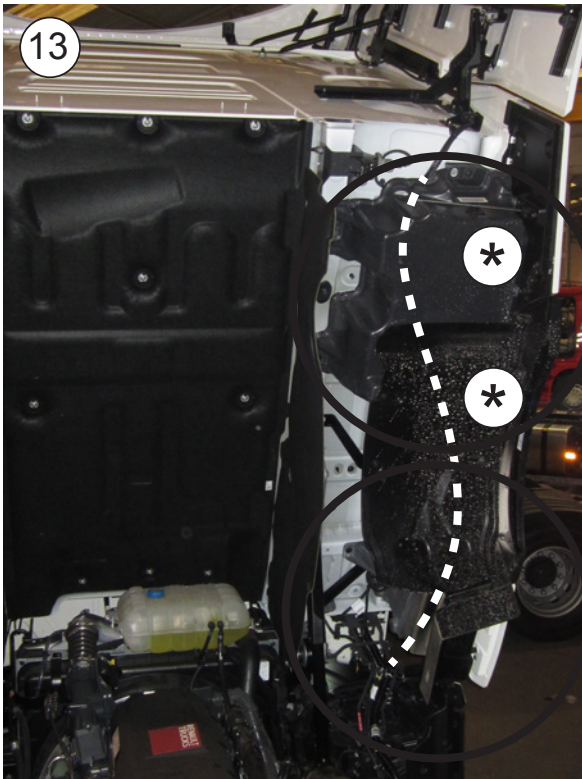

14

Laisser la cabine sur la position de marche et démonter les couvercles des connexions et le passage des câblages d'origine (\*).

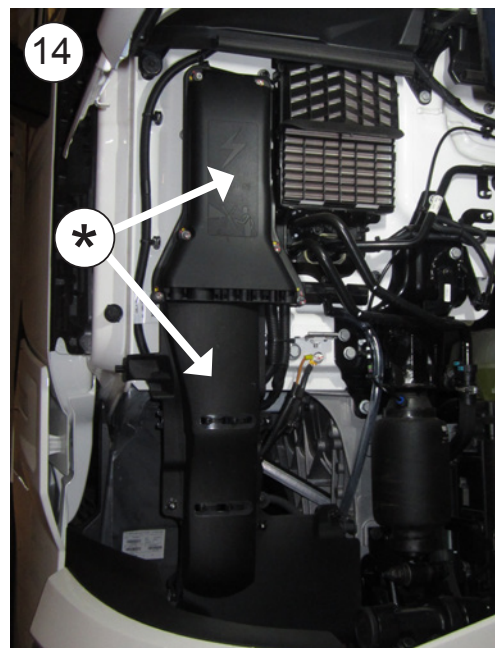



**15**

Connecter le câblage aux prises d'origine de (+) et (-), en le passant avec les câblages d'origine. Fixer le fusible avec une bride en plastique au câblage d'origine.

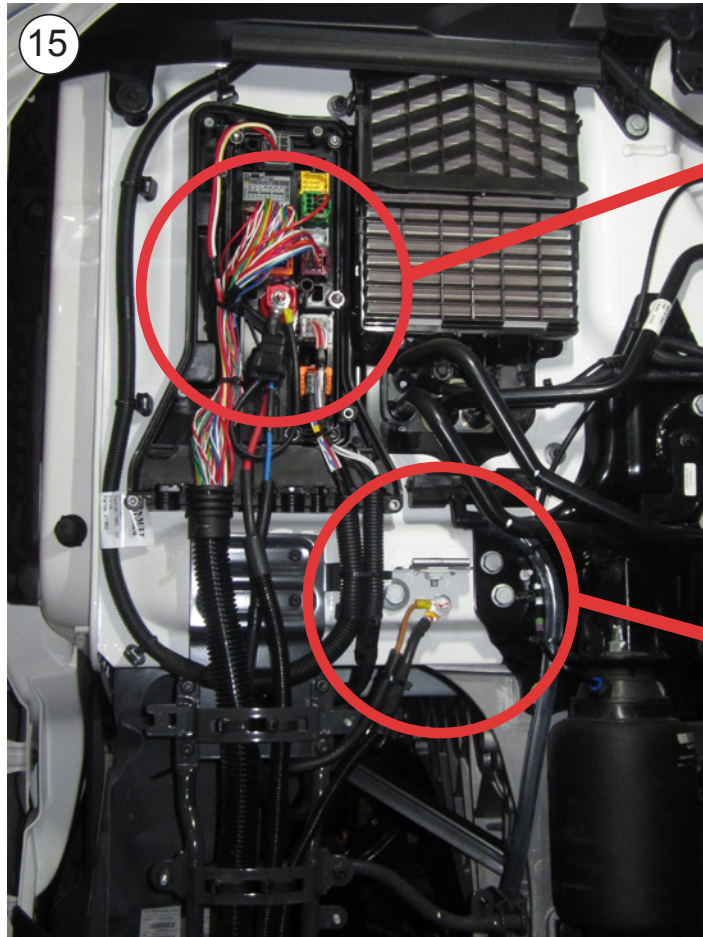
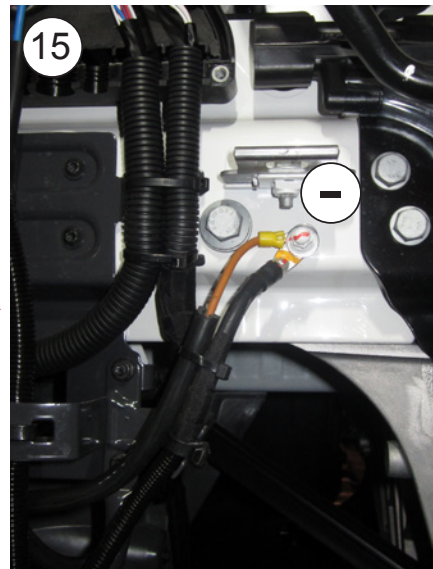
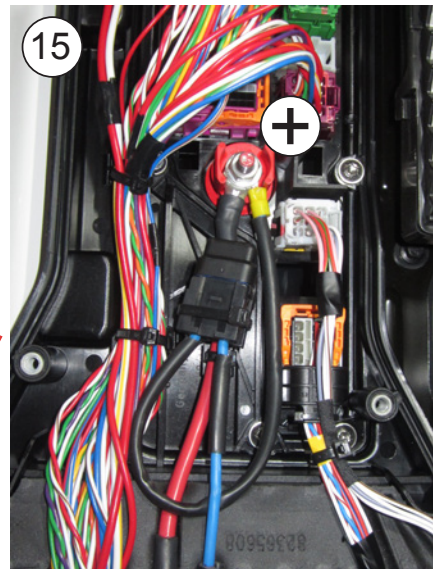

**Attention !** Avant de mettre l'équipement en marche, il faut attendre au moins une heure après avoir placé la cabine en position de marche.

Câblage électrique

AVERTISSEMENT IMPORTANT!

**Attention** de ne pas inverser les polarités au moment de connecter l'alimentation à l'équipement. Si cela se produisait, la plaque ne s'allumerait pas et l'équipement ne fonctionnerait pas.

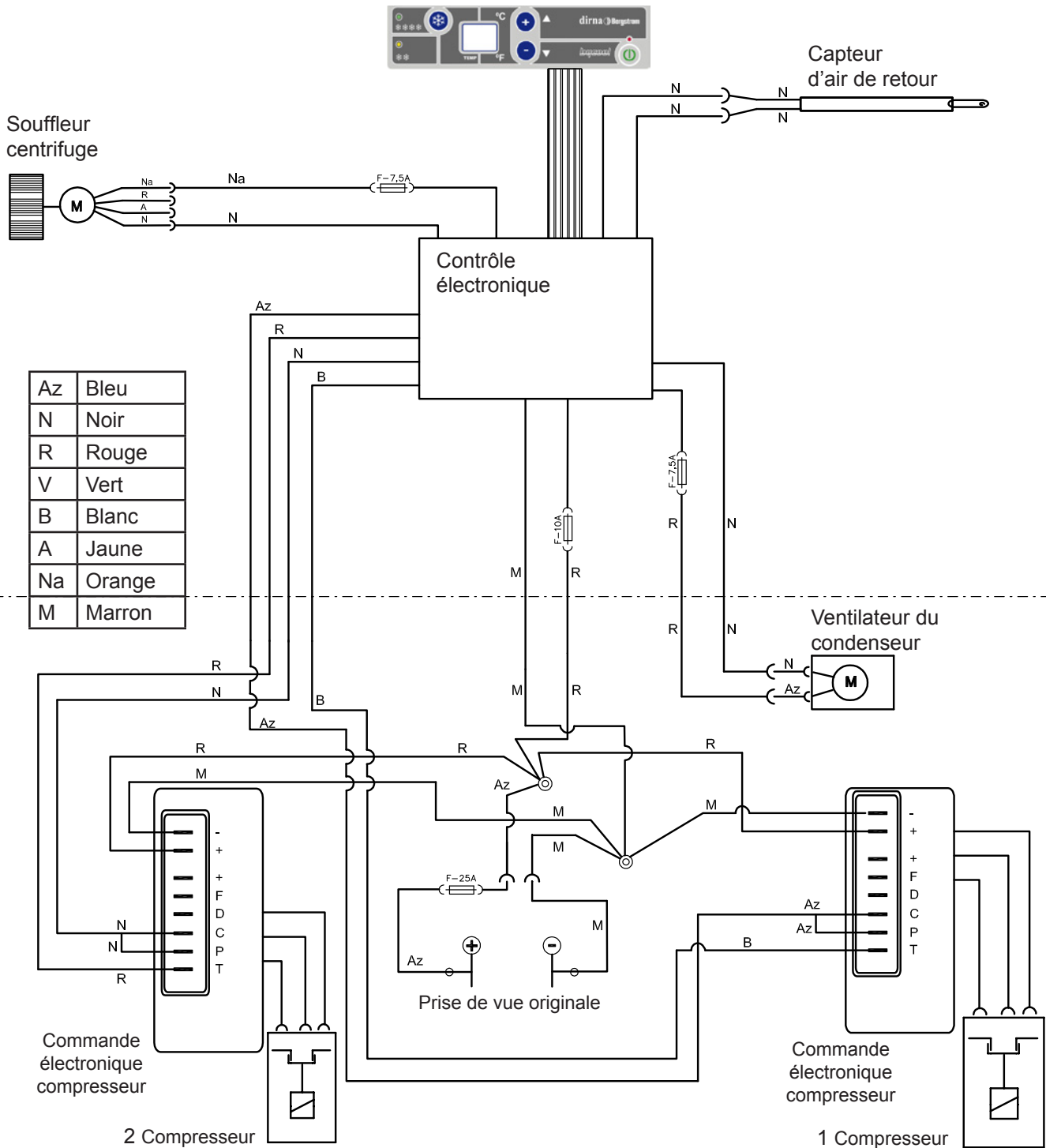

### Empfehlungen Zur montage

- Vor und während der Montage bitte diese Anweisungen lesen und beachten.
- Benutzen Sie für jeden Arbeitsschritt die geeigneten Werkzeuge.

### Elektrizität

- Zündschlüssel abziehen.
- Vor Montagebeginn die Batterie abklemmen.
- Den ordnungsgemäßen Anschluss und die korrekte Installation der Elektrokomponenten überprüfen.



**Sollte sich das Gerät während der Montage neigen, muss man mindestens 60 Minuten warten, nachdem es wieder in die horizontale Lage gebracht wurde, um es wieder einzuschalten.**



Wird die Klimaanlage im Kabinendach installiert, muss der obere Teil der Kabine mit einem Tuch oder einer Decke gegen eventuelle Kratzer geschützt werden. Bei der Installation der **Compact** auf dem Kabinendach muss darauf geachtet werden, dass mit Luken ausgestattete Kabinen über eine ausreichend stabile Struktur verfügen, um das Gewicht des Geräts stand zu halten. Sollte das Fahrzeug über keine Luke verfügen und sollte es notwendig sein, das Kabinendach aufzuschneiden, bzw. sollte die vorhandene Struktur nicht ausreichend stabil sein (z.B. wenn sie aus Faser, Kunststoff usw. hergestellt ist), obliegt es dem Installateur zu entscheiden, ob das Kabinendach zur Vermeidung von Verformungen, Brüchen, undichten Stellen usw. verstärkt werden muss, und die hierfür notwendigen Mittel bereit zu stellen.

### Werkzeuge

- Torx-Schraubenschlüssel
- Inbusschraubenschlüssel
- 10er, 13er, 14er Schraubenschlüssel
- Schere
- Metermaß

### Mitgelieferte unterlagen

Montageanweisungen	1001262644
Benutzerleitfaden	1001284900
Fehlerdiagnose	1001284902
Garantie	220AA10017

### Symbolik



Fragile



Achtung Gericht!



Elektrische Gefährdung



### Warnhinweise



Der Installateur muss im Bereich Fahrzeug-Klimaanlagen ausreichend geschult sein.



**dirna Bergstrom, s.l.** übernimmt keine Verantwortung für Schäden oder Brüche aufgrund einer nicht ordnungsgemäßen Installation oder Bedienung des Geräts oder den Austausch von Teilen bzw. Umbauten, die ohne die erforderliche schriftliche Genehmigung durchgeführt wurden.



**Mit Kältemittel vorgefülltes Gerät R-134a. (Kältemittelkreislauf nicht manipulieren).**



Siehe **Garantieverfahren** des Produkts in der **Fehlerdiagnose**.



Siehe **Benutzerleitfaden** des Geräts für den ordnungsgemäßen Betrieb der Fernbedienung und des Bedienfelds.



Die folgenden Unterlagen müssen dem Benutzer nach der Installation ausgehändigt werden: **Benutzerleitfaden**, **Garantie** und **Fehlerdiagnose**.



 Vor Montagebeginn vorderes Lufteintrittsgitter montieren.



**1** Originalkonsole für den Zugriff auf die Befestigungsschrauben durch Ziehen am Ende der Lampen abnehmen.  
Sind Leds (\*) vorhanden, für die Demontage an diesen ziehen.



**2** Luke durch Lösen der Befestigungsschrauben ausbauen (bei elektrischen Luken deren Klemme (\*) abziehen).



**3** Lukenausparung reinigen und EPDM-Dichtung 30x25 von der Außenseite des herausstehenden Teils der Lukenausparung aufkleben.



**4** **WIE DIE EPDM-DICHTUNG GESCHNITTEN WIRD, UM WASSERUNDICHTIGKEITEN IN DIE KABINE ZU VERMEIDEN**

**A-** Dichtung aufkleben und dabei einen Papierschutz von 100 mm auf jeder Seite beibehalten.

**B-** Die zwei Papierstücke entfernen.

**C-** Unter Anpressen beider Enden aufkleben.

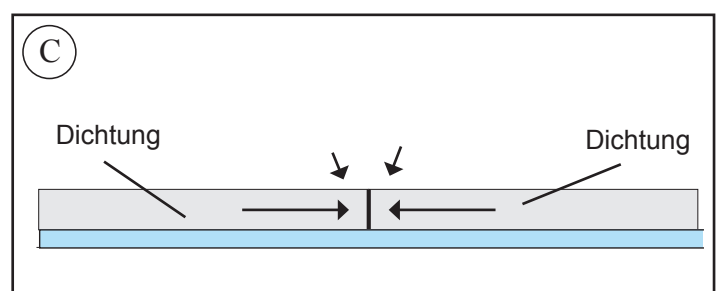
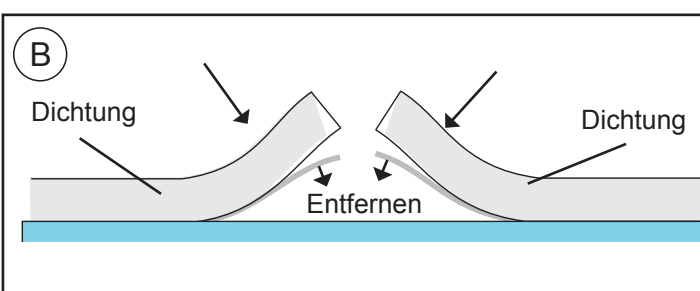
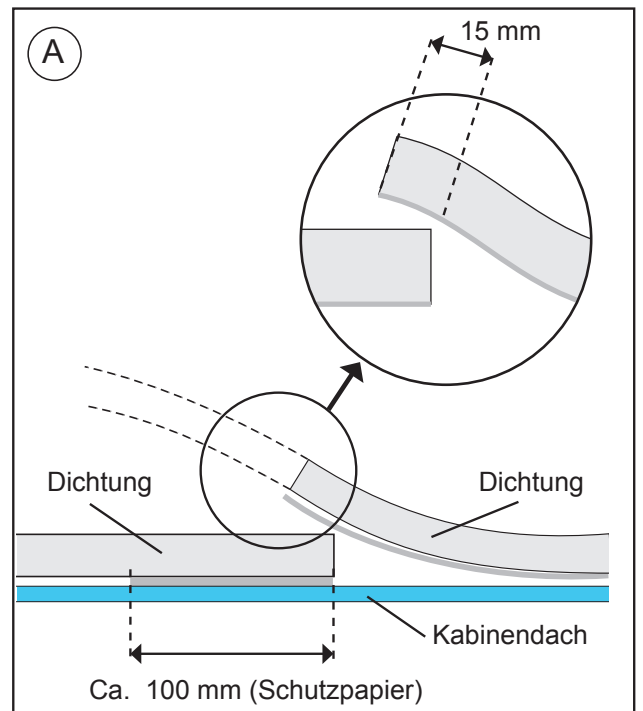

**5** Gerät auf die Lukenaussparung legen und die Führungen in die Bohrlöcher (\*) der Kabine stecken.



**6** Halterungen auf die Stiftschrauben M8 unter der Verkleidung stecken, mit (4) Flachscheiben Ø 8 und (4) selbstsichernden Muttern 8/125 fixieren. Dabei Letztere in den Rillen der Halterungen positionieren und bis zum Anschlag an die Sechskant-Verbindungen der Grundplatte anziehen.

**Achtung:** Es ist sehr wichtig, die Befestigungsklammern der Lukenkabel zu entfernen, damit die Halterungen die Kabel nicht abklemmen.





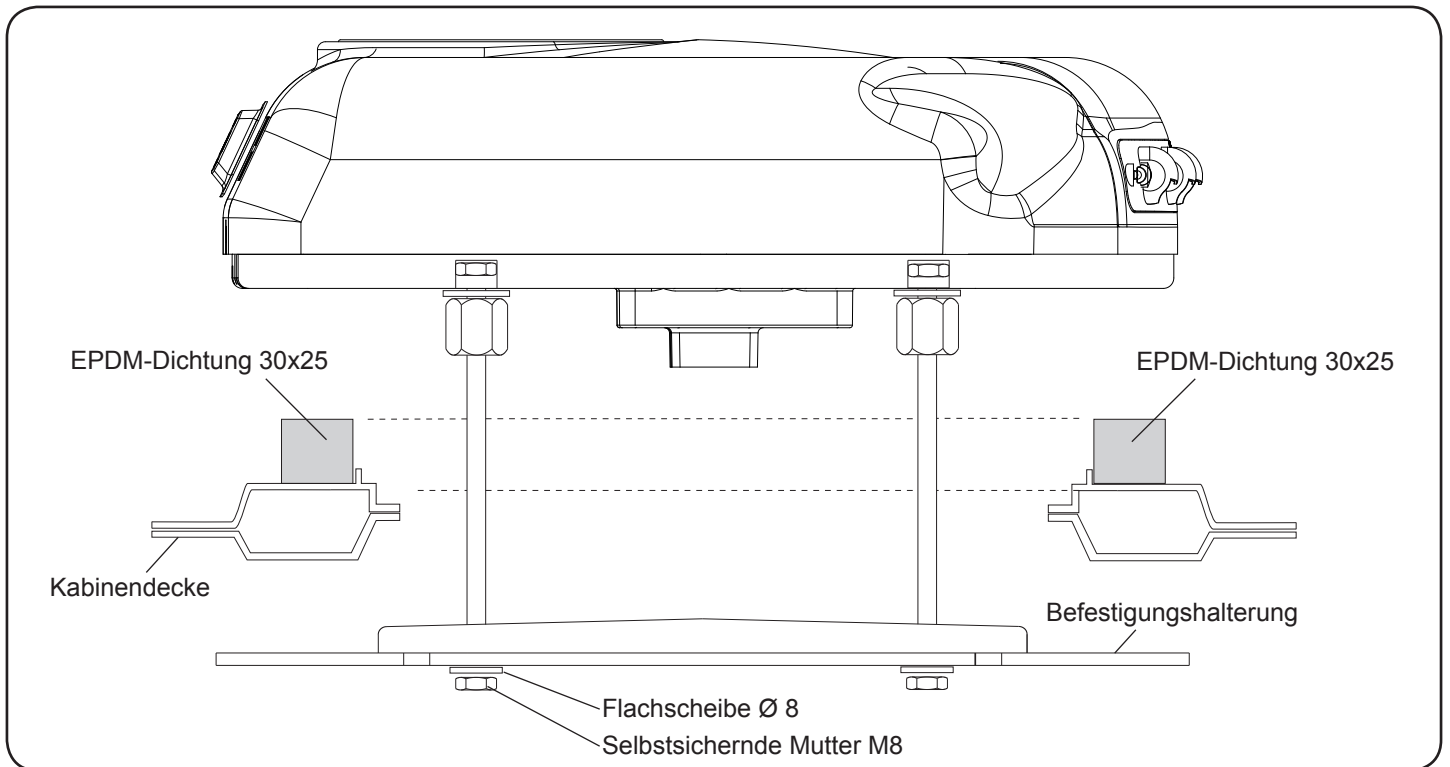

**7** Konsole auf die innere Luftverteiltertafel auflegen und mit (4) Schrauben 6/100x15 und Unterlegscheibe befestigen.



**8** Originallampen anschließen und an der Konsole durch Drücken befestigen.



**9** Netzkabel unter dem Spoiler durchführen und am Gerät anschließen. Anschlussklemmen am Dach mit Kabelhaltern und Kleber sowie Kunststoff-Kabelbindern befestigen.

**Achtung:** Den Bereich vor dem Aufkleben der Halter sorgfältig reinigen.

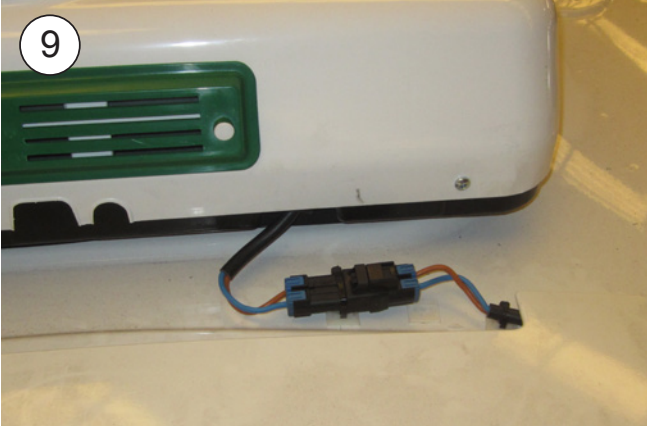
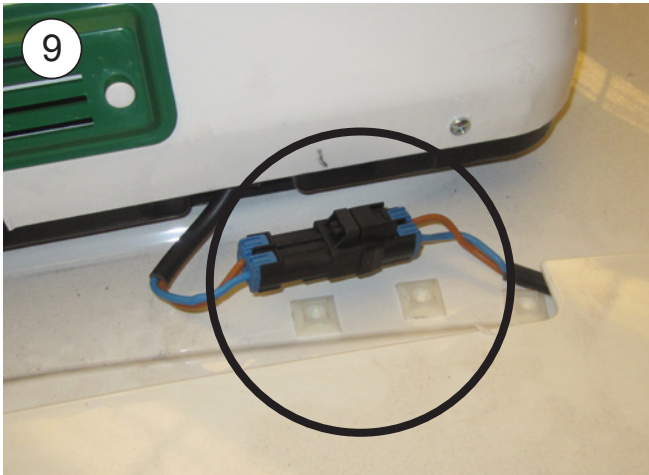

**10** Spoilerhalterungen rechts lockern und Kabel direkt an der Kabinenecke darunter hindurchführen. Spoilerhalterungen wieder in die Originalposition bringen.



**11** Kabel unter dem Spoiler mit Klebehaltern und Kabelbindern befestigen.

**Achtung:** Den Bereich vor dem Aufkleben der Halter sorgfältig reinigen.



**12** Kabel mit Klebehaltern und Kabelbindern an Kabine, seitlichem Spoilerhalter und Originalkabel befestigen.

**Achtung:** Den Bereich vor dem Aufkleben der Halter sorgfältig reinigen.

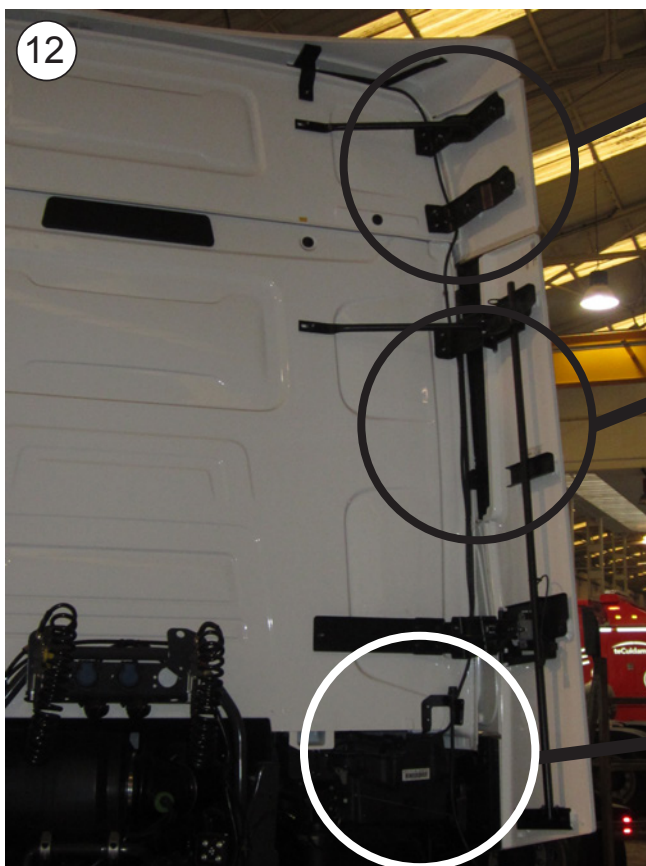
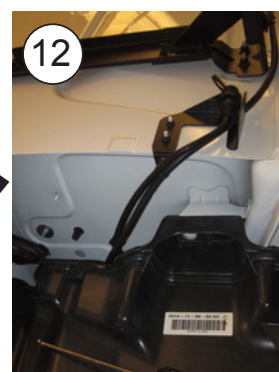
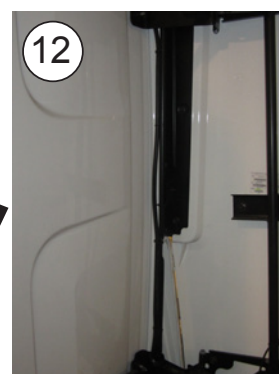



13

Kabine abklappen und Kabel unter der Schutzvorrichtung (\*) bis zum vorderen Teil der Kabine hindurchführen. Mit Kabelbindern an den Originalkabeln befestigen.

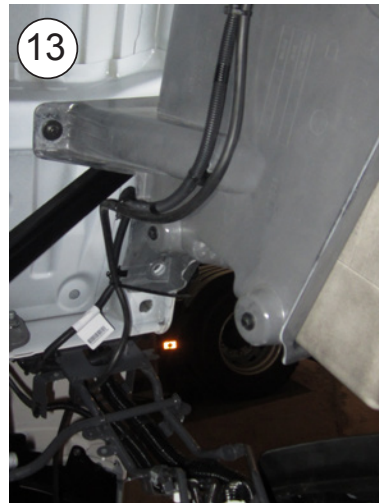
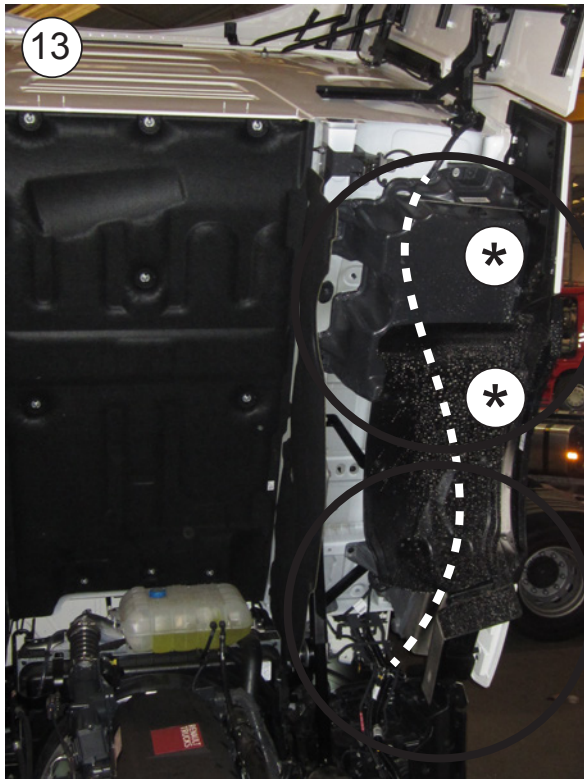

14

Kabine in Fahrposition bringen und Abdeckungen der Anschlusskästen sowie Original-Kabelführungen abnehmen (\*).

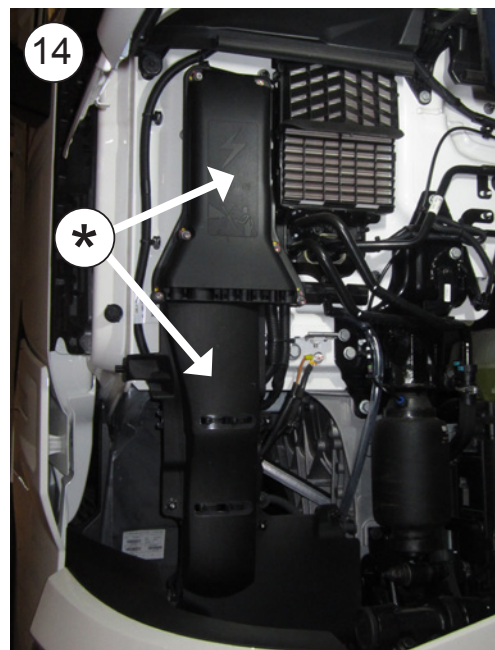

15

Kabel an Originalanschlüsse (+) und (-) anschließen und zusammen mit den Originalkabeln durchführen. Sicherung mit Kunststoff-Kabelbinder an der Originalverkabelung befestigen.

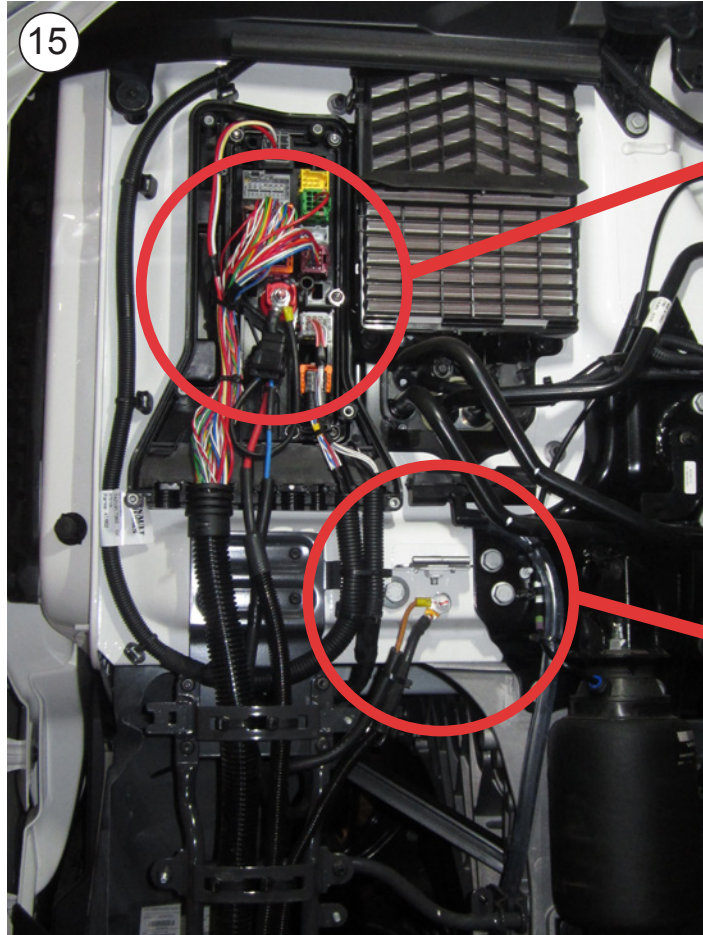
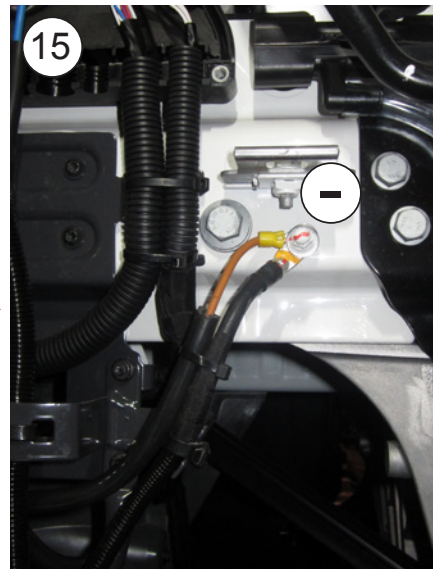
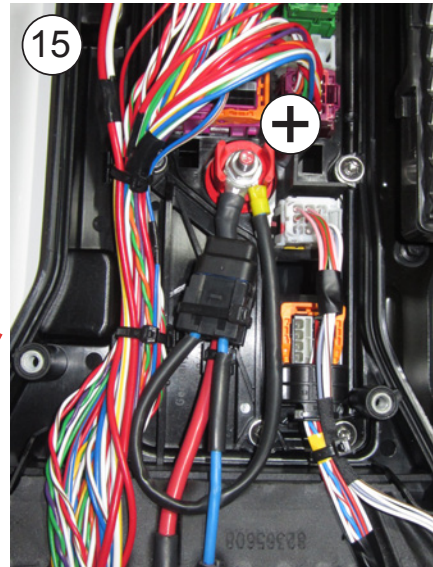

**Achtung!** Vor der Inbetriebnahme des Geräts mindestens eine Stunde warten, nachdem die Kabine in Fahrposition gebracht worden ist.

Elektrische Verkabelung

WICHTIGER WARNHINWEIS!

Darauf achten, dass die Polaritäten beim Anschluss der Stromversorgung an das Gerät nicht vertauscht werden. Ist dies der Fall, schaltet sich die Elektroniktafel nicht ein und das Gerät funktioniert nicht.

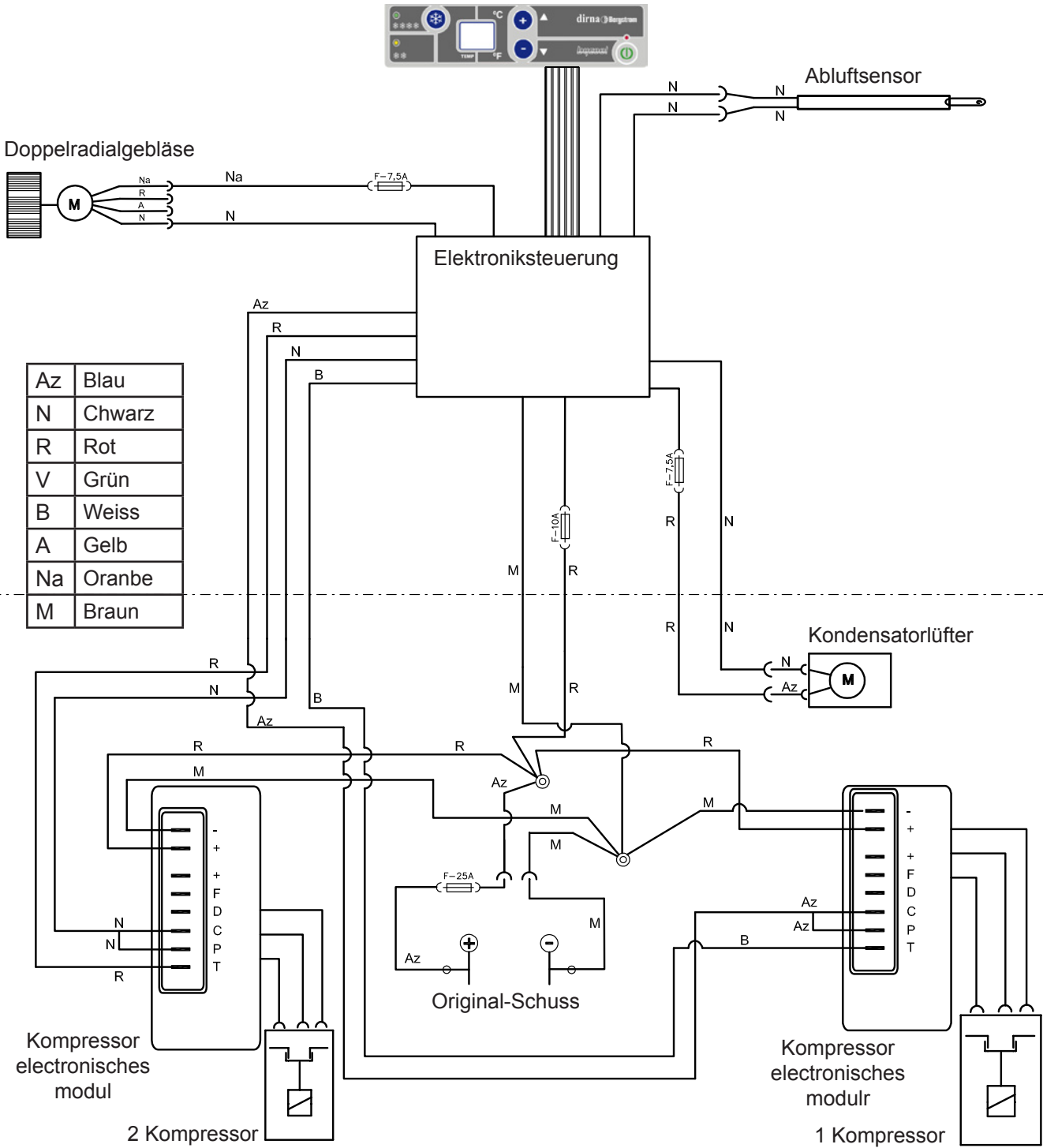



## Suggerimenti per il montaggio

- Prima di cominciare il montaggio, leggere attentamente le istruzioni e rispettarle nel corso dello stesso.
- Usare gli attrezzi più adatti ad ogni operazione.

## Elettricità

- Scollegare la chiave di contatto.
- Scollegare la batteria prima di cominciare il montaggio.
- Assicurarsi di avere effettuato correttamente l'installazione e il collegamento dei componenti elettrici.

### Attenzione

Se durante il montaggio si inclina l'impianto, prima di rimetterlo in funzione occorre attendere almeno 60 minuti dal momento in cui è di nuovo in posizione orizzontale.

### Attenzione

Quando si installa l'impianto di aria condizionata sul tettuccio, bisogna proteggere la parte superiore della cabina con uno straccio o una coperta per evitare eventuali graffi. Per l'installazione del **Compact**, tenere presente che normalmente le cabine munite di oblò dispongono di una struttura abbastanza solida per sostenere il peso dell'impianto. Tuttavia, se così non fosse e se fosse necessario tagliare il tettuccio, o se in presenza di oblò la struttura non fosse abbastanza rigida (se fosse di fibra, plastica, ecc.), è responsabilità dell'installatore decidere se occorre rinforzare il tettuccio per evitare qualsiasi deformazione, rottura o penetrazione d'acqua, ecc., prendendo le misure necessarie per evitarlo.

## Attrezzi

Kit di chiavi Torx  
 Kit di chiavi Allen  
 Chiave fissa 10, 13, 14  
 Forbici  
 Metro a nastro

## Documentazione allegata

Istruzioni di montaggio	1001262644
Guida dell'utente	1001284900
Soluzione dei problemi	1001284902
Garanzia	220AA10017

## Simbologia



Fragile





Attenzione alle mani





Tensione elettrica pericolosa

### Avvertenze

 L'installatore deve essere in possesso della formazione necessaria in materia di aria condizionata per veicoli.

 **dirna Bergstrom, s.l.** declina ogni responsabilità per danni o rotture derivanti dall'errata installazione o dall'errato uso dell'impianto o da sostituzioni o modifiche effettuate senza la necessaria autorizzazione per iscritto.

 **Impianto precaricato con gas refrigerante R-134. (Non manomettere il circuito di gas refrigerante).**

 Vedi la **procedura di garanzia** del prodotto in **Diagnosi dei problemi**.

 Vedi la **Guida dell'utente** dell'impianto per il corretto funzionamento del telecomando e del pannello di controllo.

 I seguenti documenti devono essere consegnati all'utente una volta conclusa l'installazione: **Guida dell'utente, Garanzia e Diagnosi dei problemi**.

 Prima di cominciare il montaggio, montare la griglia anteriore d'entrata dell'aria.



**1** Smontare la console originale, tirando l'estremità delle luci per accedere alle viti di fissaggio.  
In presenza di led (\*) smontare tirando questi ultimi.



**2** Smontare il tettuccio apribile svitando le viti di fissaggio (in caso di tettuccio elettrico, disinserire il relativo morsetto [\*]).



3

Pulire il contorno del vano e incollare la guarnizione EPDM 30x25, dall'esterno della sporgenza perimetrale.



4

**COME TAGLIARE LA GUARNIZIONE EPDM PER EVITARE INFILTRAZIONI NELLA CABINA**

**A-** Incollare la guarnizione mantenendo una protezione di carta di 100 mm su ogni lato.

**B-** Rimuovere i due pezzi di carta.

**C-** Incollare premendo su entrambe le estremità.

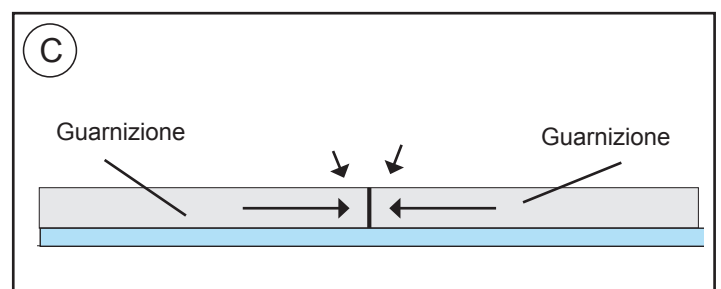
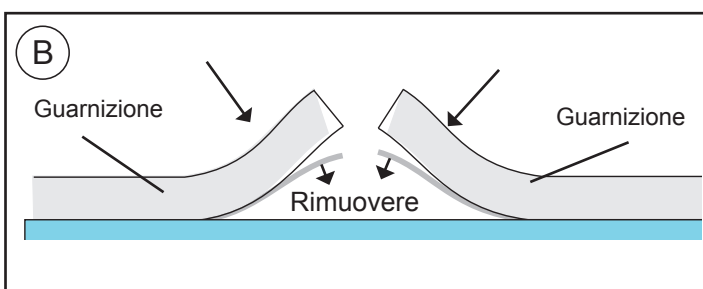
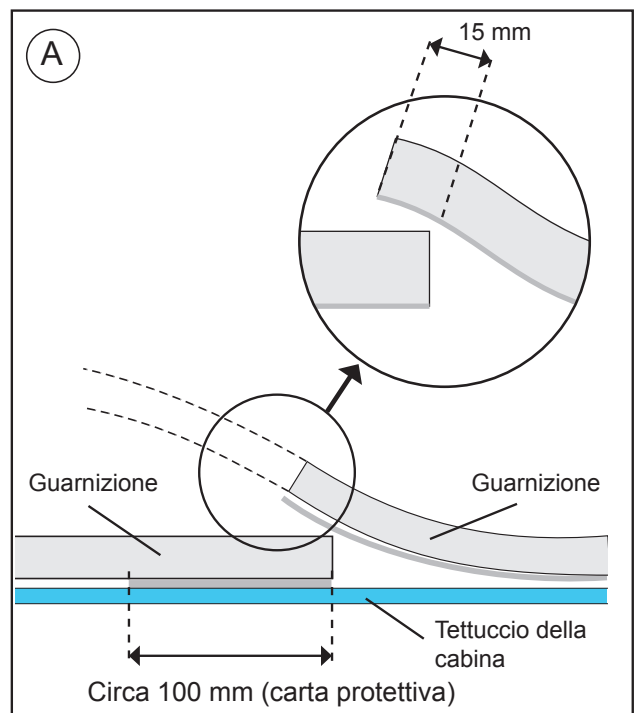



**5** Sistemare l'impianto sul vano del tettuccio, inserendo le guide nei fori (\*) della cabina.



**6** Inserire i supporti sulle viti prigioniere M8, sotto la tappezzeria, fissare con (4) rondelle piane Ø 8 e (4) dadi 8/125 autobloccanti inseriti nelle scanalature dei supporti e stringendo fino a battuta con i perni esagonali della base.

**Attenzione:** è molto importante togliere le graffe di fissaggio del cablaggio del tettuccio per evitare che i supporti schiaccino i cavi.



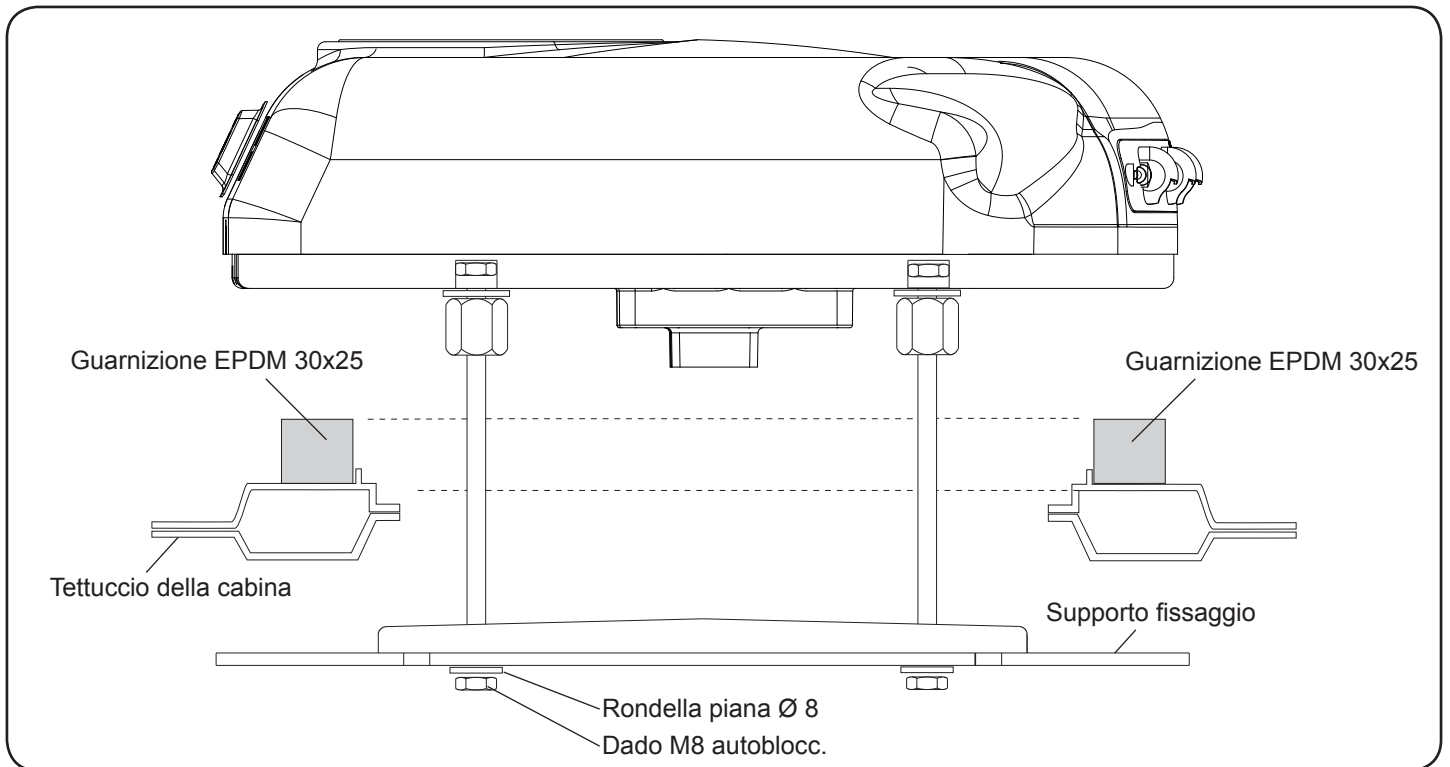

**7** Posizionare la console sul pannello interno di distribuzione dell'aria e fissare con (4) viti 6/100x15 con rondella.



**8** Collegare le luci originali e inserirle a pressione nella console.



**9** Far passare il cablaggio di alimentazione sotto lo spoiler e collegarlo all'impianto, fissare i morsetti di connessione al tettuccio con i supporti adesivi e le fascette di plastica.

**Attenzione: pulire bene la zona prima di incollare i supporti adesivi.**

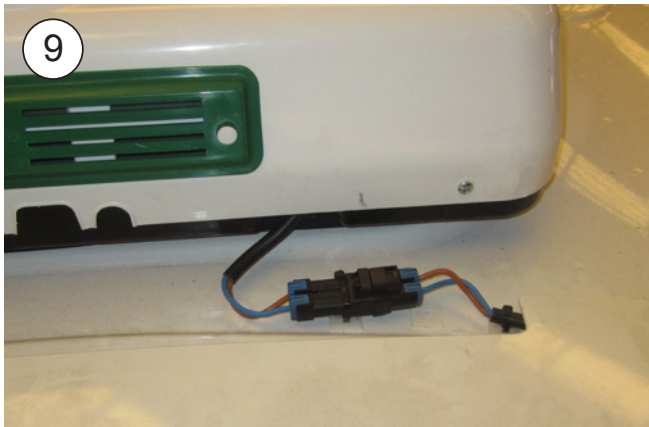
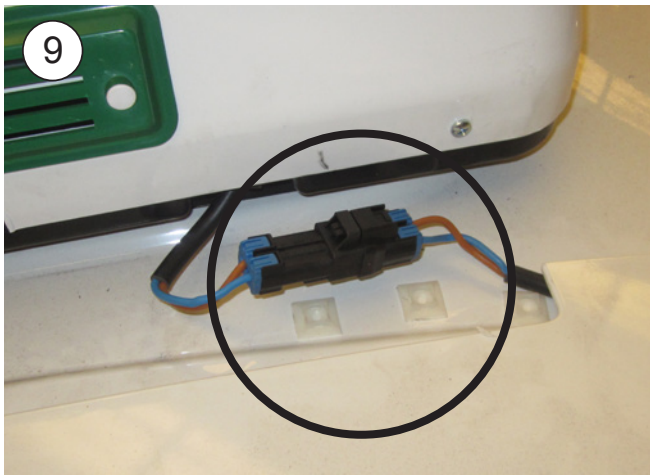

**10** Allentare i supporti dello spoiler, sul lato destro, e far passare il cablaggio al di sotto degli stessi, sullo spigolo della cabina e rimettere a posto i supporti dello spoiler.





**11** Fissare il cablaggio sotto lo spoiler con i supporti adesivi e le fascette di plastica.

**Attenzione:** pulire bene la zona prima di incollare i supporti adesivi.



**12** Fissare il cablaggio con i supporti adesivi e le fascette alla cabina, al supporto dello spoiler laterale e al cablaggio originale.

**Attenzione:** pulire bene la zona prima di incollare i supporti adesivi.

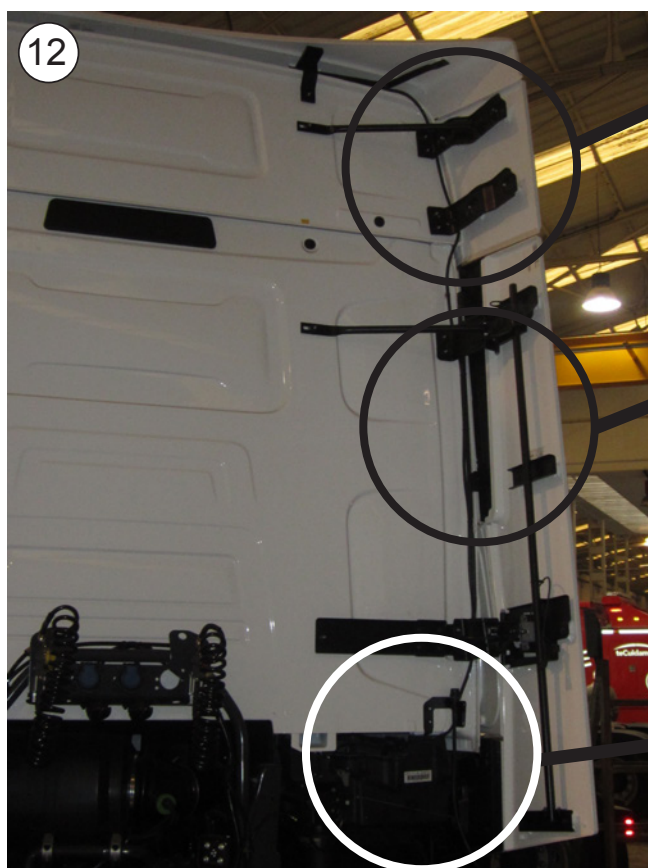
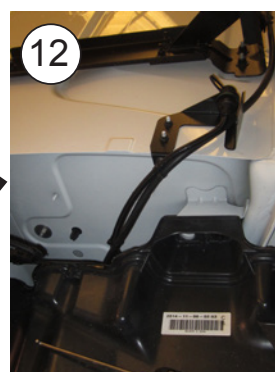
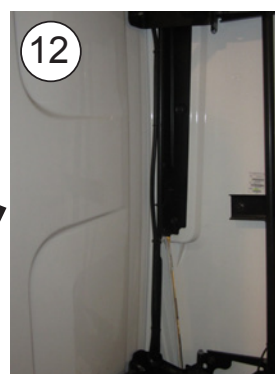

**13** Ribaltare la cabina e far passare il cablaggio al di sotto della protezione (\*) verso la parte anteriore della cabina, fissandolo con le fascette al cavo originale.

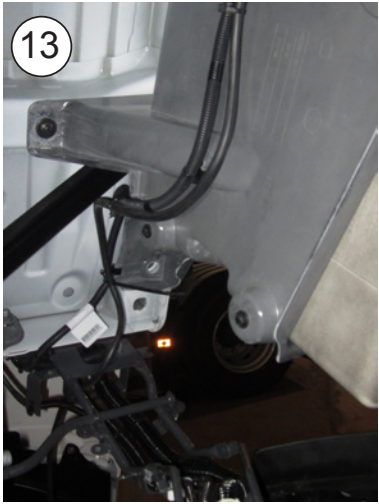
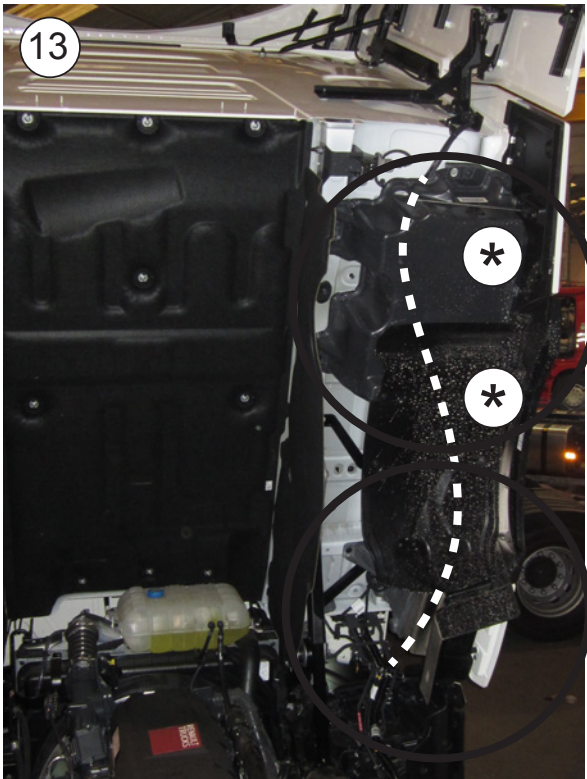

**14** Mettere la cabina in posizione di marcia e smontare i coperchi delle connessioni e il passaggio dei cablaggi originali (\*).

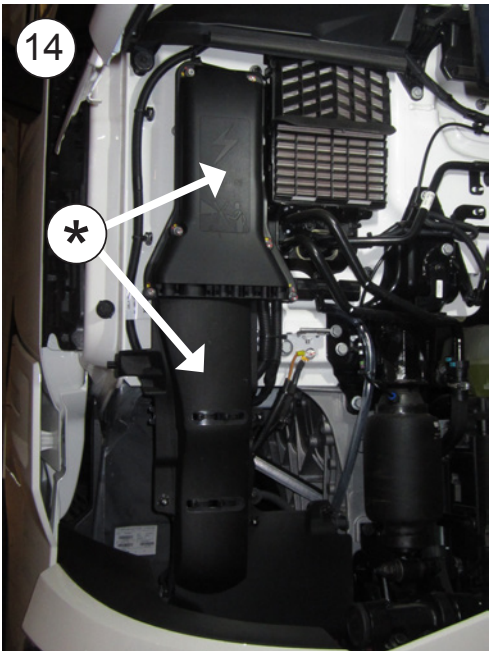



15

Collegare il cablaggio alle prese originali (+) e (-) facendolo passare con i cablaggi originali. Fissare il fusibile con una fascetta di plastica al cablaggio originale.

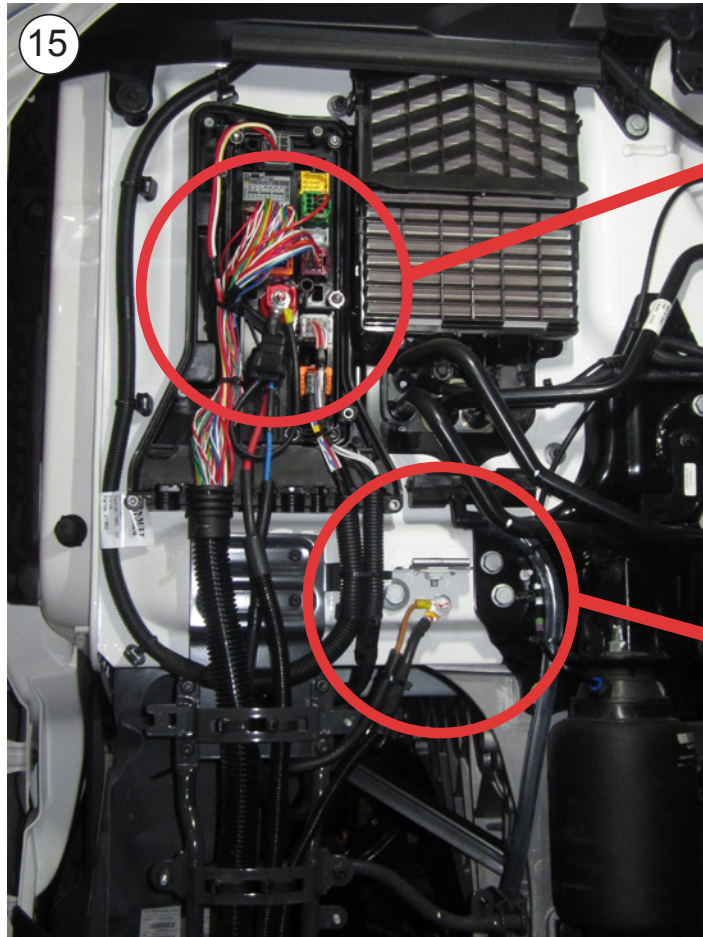
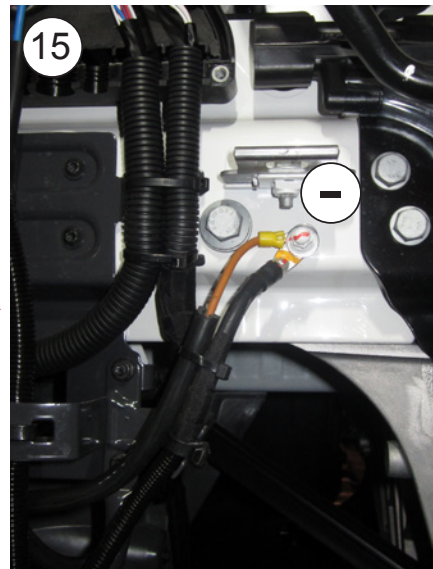
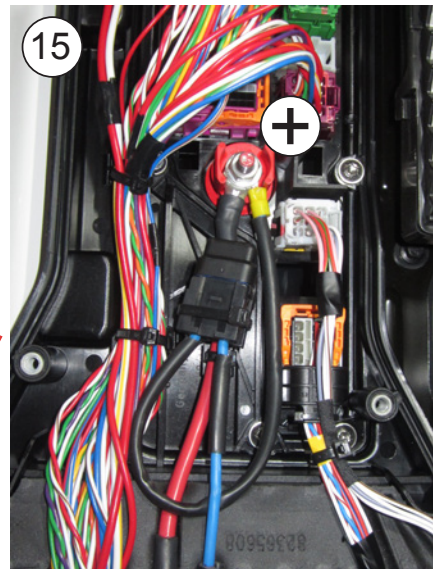

**Attenzione:** prima di mettere in funzione l'impianto occorre attendere almeno un'ora dopo aver rimesso la cabina in posizione di marcia.



Cablaggio elettrico

AVVISO IMPORTANTE!

Fare attenzione a non invertire le polarità quando si esegue il collegamento dell'impianto. Infatti, in tal caso il quadro comandi non si accende e l'impianto non funziona.

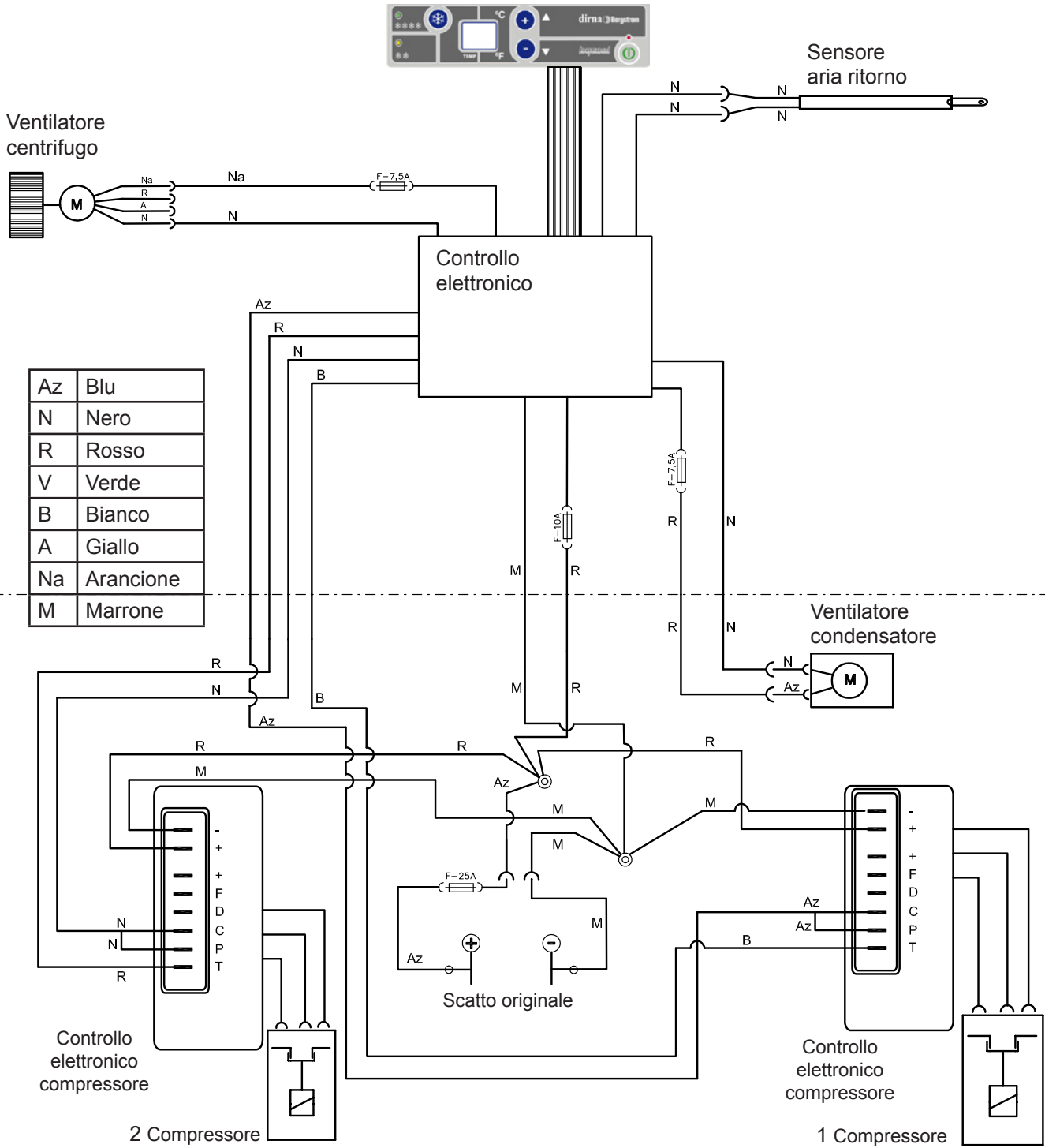

Ed:	18/03/2016
Md:	07/08/2019

b



Francisco Alonso, 6  
28806 Alcalá de Henares, Madrid  
SPAIN

Contact	Phone	Fax	E-Mail
Sales (Ventas Internacional)	+34 91 8770510	+34 91 8771158	sales@dirna.bergstrominc.com
Comercial Nacional	+34 91 8775841	+34 91 8836321	ventas@dirna.bergstrominc.com
Orders & Deliveries (Logística internacional)	+34 91 8775846	+34 91 8771158	export@dirna.bergstrominc.com
Orders & Deliveries (Logística nacional)	+34 91 8775840	+34 91 8836321	comercial@dirna.bergstrominc.com
Technical Assistance (Internacional)	+49 511 86679681	+49 511 86679710	technicalassistance@dirna.bergstrominc.com
Technical Assistance (Nacional)	+34 91 8775845	+34 91 883 6321	oblanco@dirna.bergstrominc.com

[www.dirna.com](http://www.dirna.com)

	<b>ATENCIÓN:</b>	Dirna Bergstrom se reserva el derecho de efectuar modificaciones en cualquier momento de los datos contenidos en esta publicación, por razones técnicas o comerciales.
	<b>NOTE:</b>	<i>For technical and commercial reasons, Dirna Bergstrom reserves the right to change the data contained in this brochure.</i>
	<b>ATTENTION:</b>	Dirna Bergstrom se réserve le droit d'effectuer à tout moment des modifications des données reprises sur cette publication, pour des raisons techniques ou commerciales.
	<b>HIWEIS:</b>	<i>Dirna Bergstrom behält sich vor, aus technischen oder kaufmännischen Gründen jederzeit Änderungen der Angaben dieser Veröffentlichung vorzunehmen.</i>
	<b>ATTENZIONE:</b>	Dirna Bergstrom si riserva il diritto di effettuare modifiche in qualsiasi momento ai dati contenuti in questa pubblicazione, per motivi tecnici o commerciali.