

CE

dirna  Bergstrom.

biycool!
green line

COMPACT 1.4

RENAULT T High sleeper cab



Instrucciones de Montaje

Mounting Instructions

Instructions de Montage

Montageanweisungen

Istruzioni di Montaggio

ES Spanish

EN English

FR French

GE German

IT Italian

F-4218 rev.01



1001261110

Recomendaciones Para el montaje

- Antes de iniciar el montaje leer las instrucciones y seguirlas durante el proceso de instalación.
- Usar las herramientas adecuadas para cada operación.

Electricidad

- Desconectar la llave de contacto.
- Desconectar la batería antes de empezar el montaje.
- Asegurar el conexionado de los componentes eléctricos, verificando su correcto encaje.

Atención

Si durante el montaje el equipo se inclina ó se abate la cabina con el equipo montado, se deberá esperar un mínimo de 60 minutos, desde que el equipo quede horizontal, antes de ponerlo en marcha.

Atención

Al instalar el equipo de aire acondicionado en el techo se debe proteger la parte superior de la cabina con un paño ó manta protectora para evitar posibles arañazos. Al instalar **Compact** en el techo hay que tener en cuenta que, normalmente, las cabinas que vienen provistas de escotilla, tienen una estructura suficiente para soportar el peso del equipo. Sin embargo, cuando no ocurra así y sea necesario realizar corte en el techo ó incluso si en el caso de llevar escotilla el material no es lo suficientemente resistente (caso de techo de fibra, plástico, etc...) es el instalador el que debe decidir, **bajo su responsabilidad**, sobre la necesidad de reforzar el techo para evitar posibles deformaciones, roturas, entradas de agua, etc... habilitando los medios para que esto no ocurra.

Herramientas

Juego de Llaves Torx

Juego de Llaves Allen

Llave fija 10, 13, 14

Tijeras

Flexómetro

Documentación incluida

Instrucciones de montaje 1001261110

Listado de recambios 220RE00215

Simbología



Frágil





Atención corte!



Riesgo eléctrico

Advertencias

 El personal instalador debe poseer una formación suficiente en Aire Acondicionado de vehículos.

 **dirna Bergstrom, s.l.** queda exenta de responsabilidad si se producen averías que procedan de una inadecuada manipulación ó instalación del equipo, ó por modificaciones y sustituciones efectuadas sin nuestra expresa autorización por escrito.

 **Equipo precargado con gas** refrigerante R-134a. **(No manipular el circuito de gas refrigerante).**

 Véase **procedimiento de garantía** del producto incluido en **Diagnosis de Averías**.

 Véase **Manual de Usuario** del equipo para el correcto funcionamiento del mando a distancia y del panel de control.

 Al finalizar la instalación se debe entregar al usuario: **Manual del Usuario, Garantía y Diagnosis de averías.**

 Antes de empezar con el montaje, montar rejilla entrada aire delantera.



1 Desmontar consola original, tirando del externo de las luces para acceder a los tornillos de fijación.
En el caso de llevar leds (*) desmontar tirando de ellos.



2 Desmontar escotilla quitando tornillos de fijación de la misma (en escotilla eléctrica desconectar clema (*) de la misma).



3

Limpiar el área de la escotilla de la posible suciedad y grasa adherida antes de pegar la junta EPDM. Pegar la junta EPDM 30x25 por el resalte del contorno del hueco de la escotilla.



4

COMO CORTAR LA JUNTA EPDM PARA EVITAR FILTRACIÓN DE AGUA EN LA CABINA

- A- Pegar la junta, manteniendo 100 mm de papel protector por cada lado.
- B- Quitar los dos piezas de papel.
- C- Pegue presionado ambos finales.

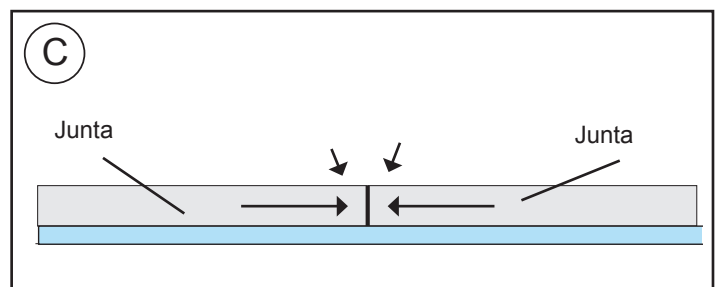
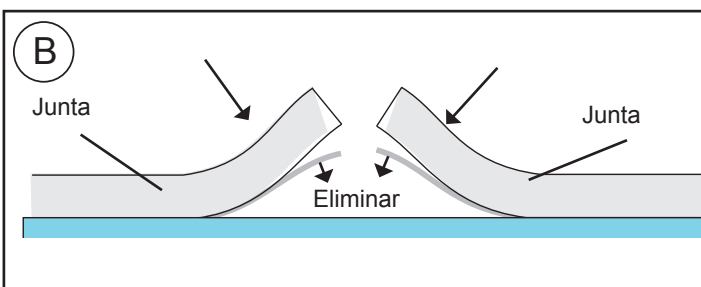
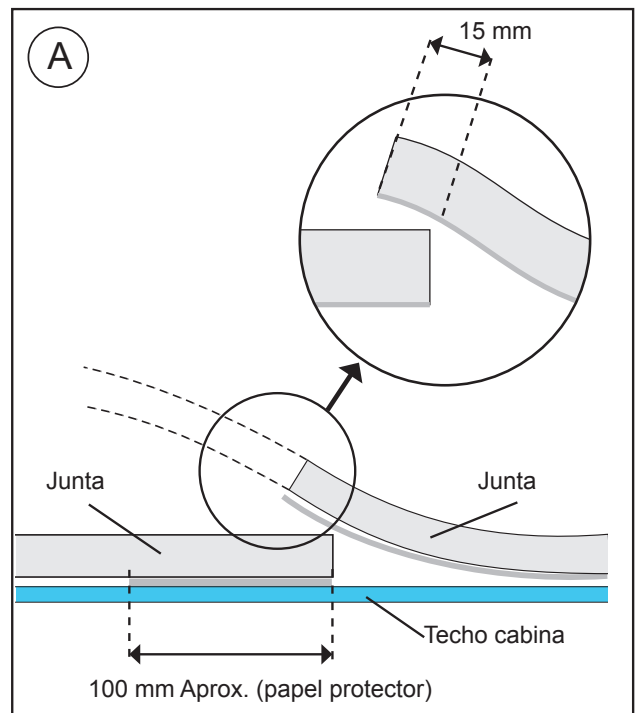

5 **Exterior cabina:** Posicionar el equipo en el hueco de la escotilla.
Atención: Al colocar el equipo encima del hueco escotilla, revisar que las salidas de desagüe no queden obstruidas por la junta EPDM.

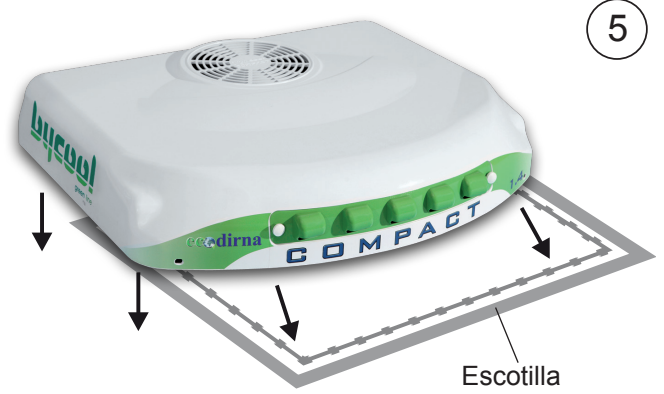

6 Colocar acoplamiento canalizador quedando la parte más blanda en la base del equipo.



7 Montar arandelas en separadores como se indica.

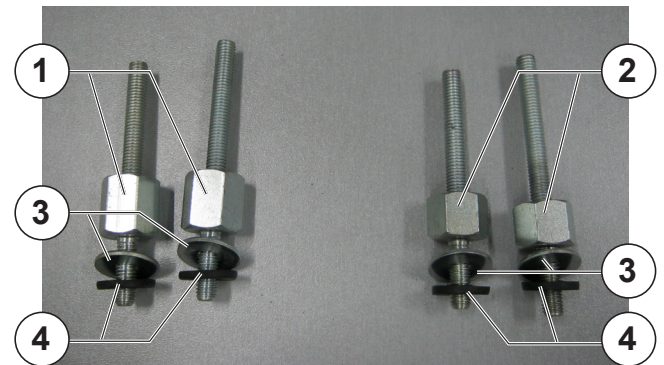

- 1.- Separador 22 mm
- 2.- Separador 17 mm
- 3.- Arandela plana Ø 8 ala ancha
- 4.- Arandela goma Ø 20 x Ø 7 x 3 mm

8 Montar arandelas en separadores como se indica.

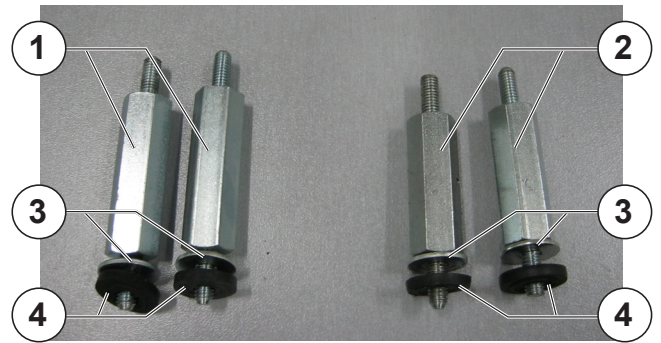

- 1.- Separador 50 mm
- 2.- Separador 43 mm
- 3.- Arandela plana Ø 8 ala ancha
- 4.- Arandela goma Ø 18 x Ø 6 x 3 mm

9 Montar y apretar separadores teniendo en cuenta la posición según sus medidas.





- 1.- Separador M8 22 mm
- 2.- Separador M8 17 mm
- 3.- Separador M6 50 mm
- 4.- Separador M6 43 mm

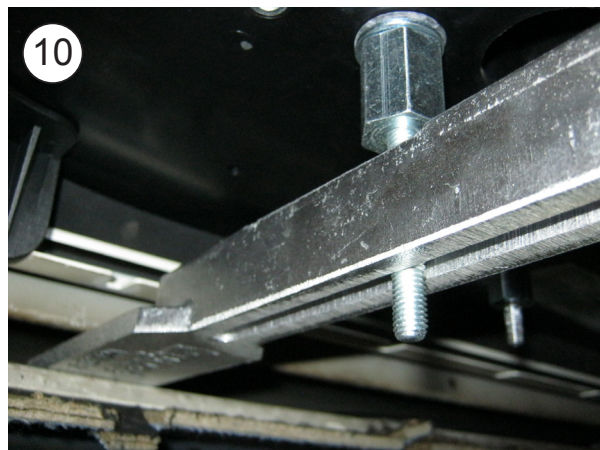

- 1.- Separador M8 22 mm
- 2.- Separador M8 17 mm
- 3.- Separador M6 50 mm
- 4.- Separador M6 43 mm

10 Introducir soportes en espárragos M8 por debajo del tapizado. Poner (4) arandelas planas Ø 8 ala ancha y (4) tuercas M8 autoblocantes sin llegar a apretar totalmente.



 **Precaución:** Tener cuidado de no pillar el cableado de la escotilla.



11

Conectar la caja de 2 vías del sensor del aire de retorno, la caja de 4 vías del soplador y la de 8 vías de conexión de los cableados del control electrónico.

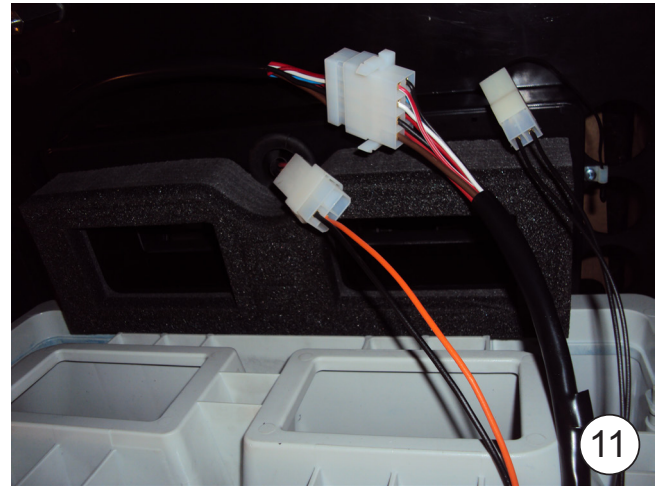

12

Montar panel interior de distribución de aire con (4) hexágonos teniendo en cuenta su posición según medidas.

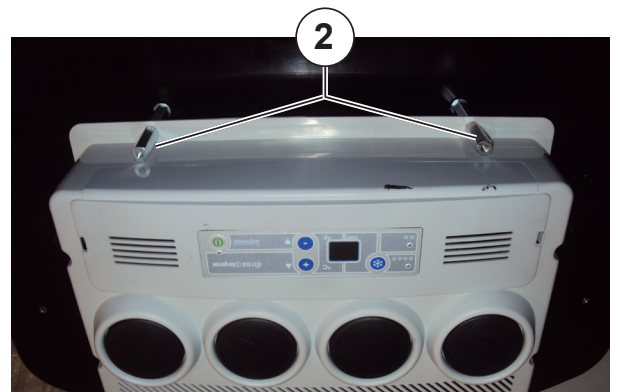
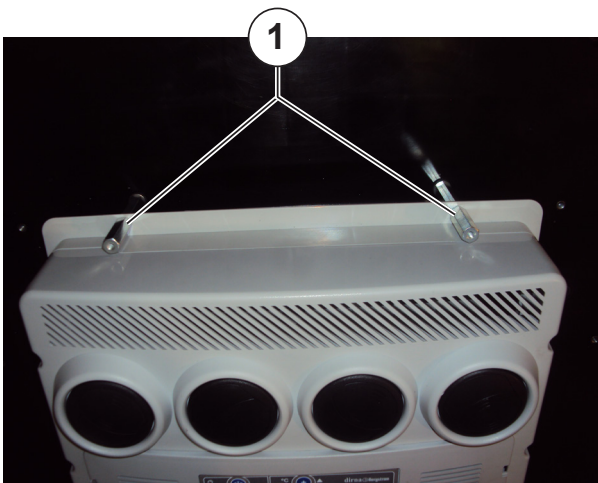

- 1.- Separador 50 mm en parte delantera
- 2.- Separador 43 mm en parte trasera

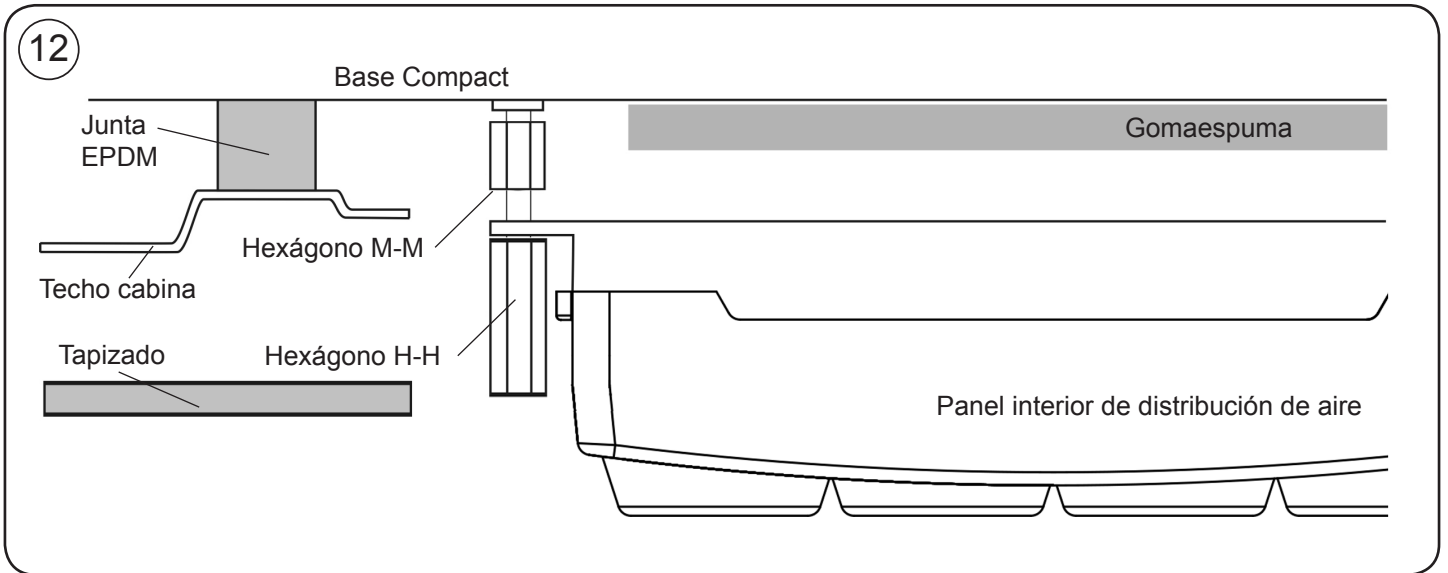

13 Montar consola apuntando (4) tornillos M6x16 y centrar el equipo hasta hacer coincidir la consola en la ubicación del tapizado donde estaba montada la consola original.



14 Una vez centrado, desmontar consola y apretar los soportes hasta que hagan tope con los hexágonos.

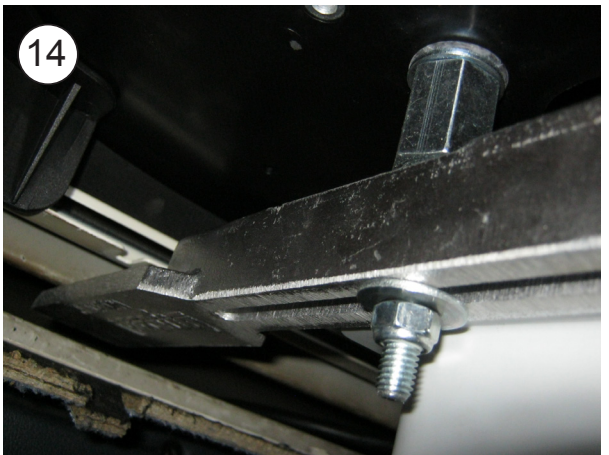

15 Verificar por el exterior que los desagües del equipo están libres y no interfieren con la junta EPDM del equipo.

16 Volver a montar la consola con tornillos M6x16 apretando hasta hacer tope con los hexágonos.



17 Conectar las luces y encajarlas presionando en la consola.



VISTA EXPLOSIONADA HASTA FIJACIÓN DE LOS SOPORTES

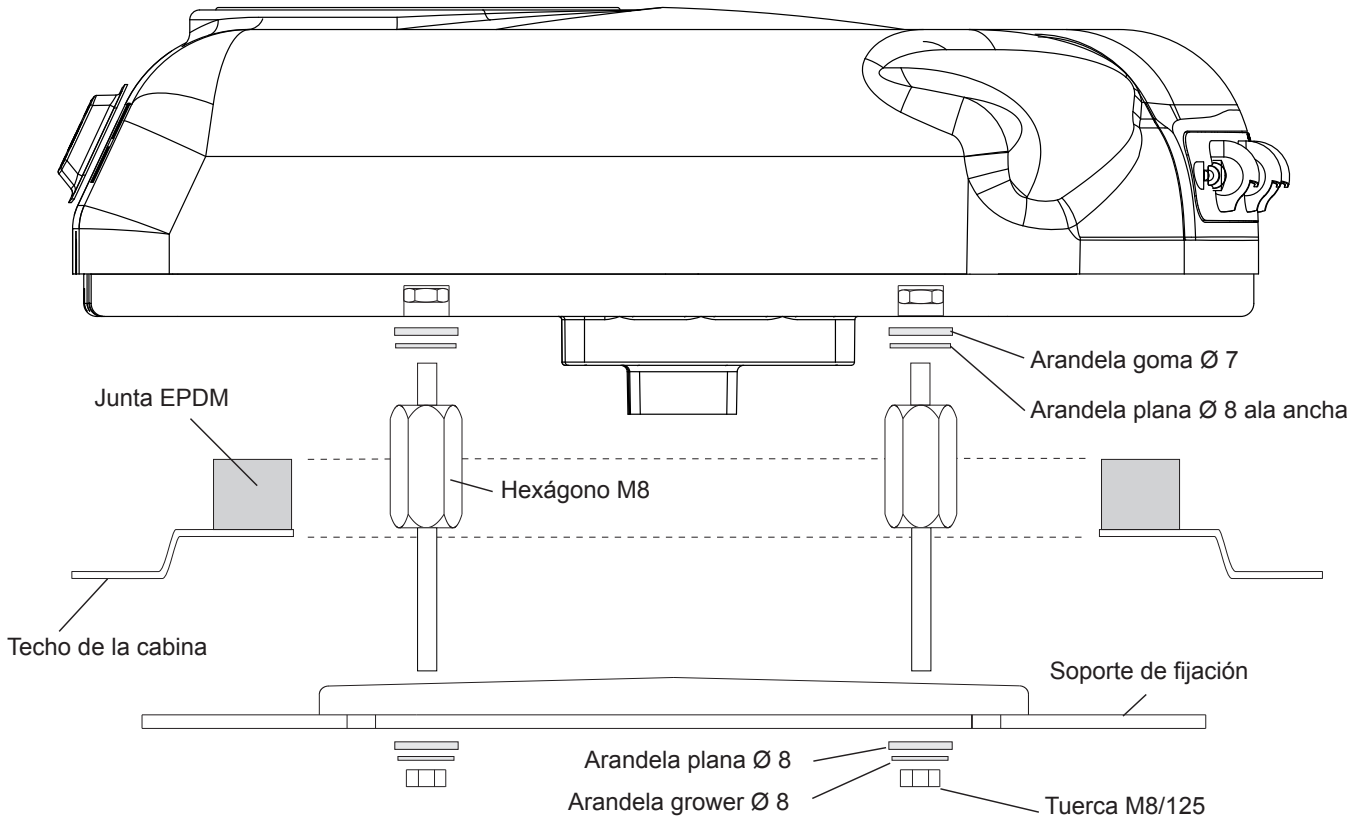

VISTA EXPLOSIONADA HASTA LA FIJACIÓN DE LAS CONSOLAS

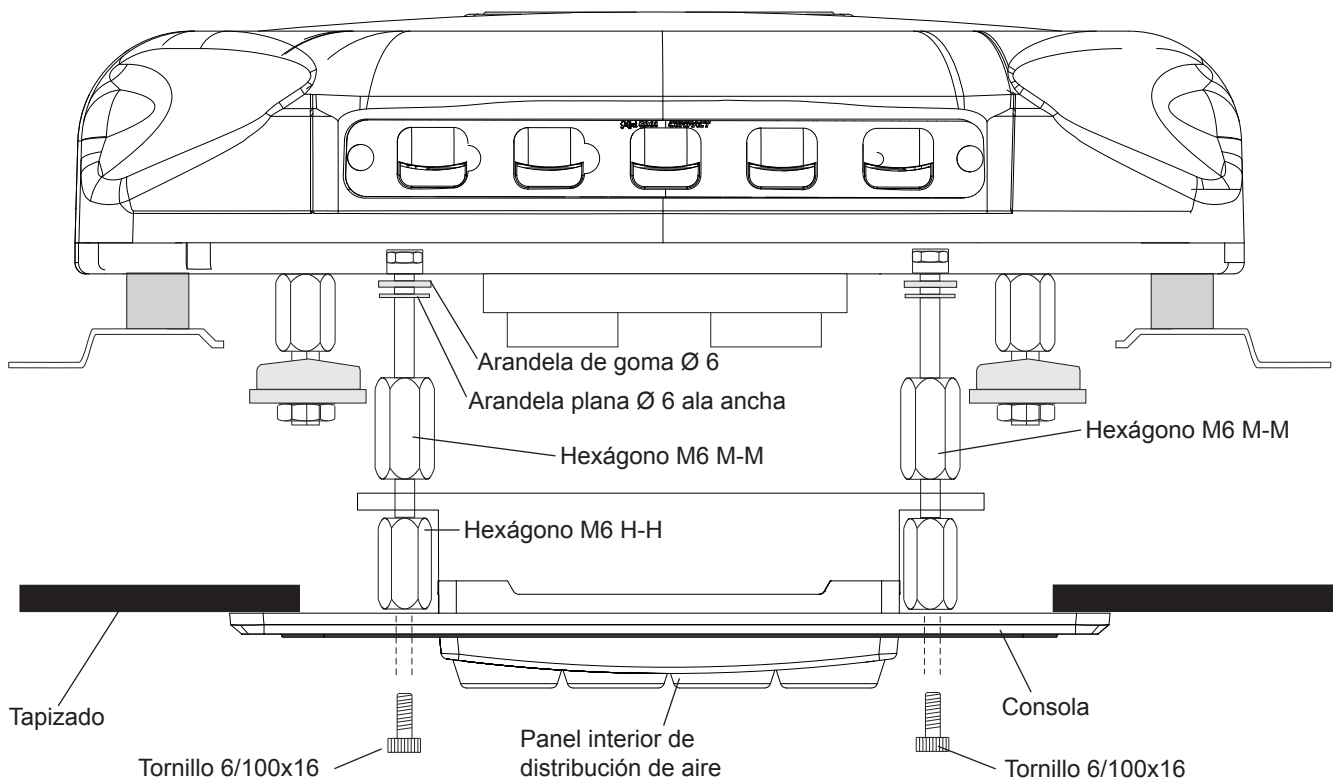

18

Pasar cableado de alimentación por debajo del spoiler y conectar con equipo, fijar clemas de conexión al techo con soportes con adhesivo y bridas de plástico.

Atención: limpiar bien la zona antes de pegar los soportes con adhesivo.

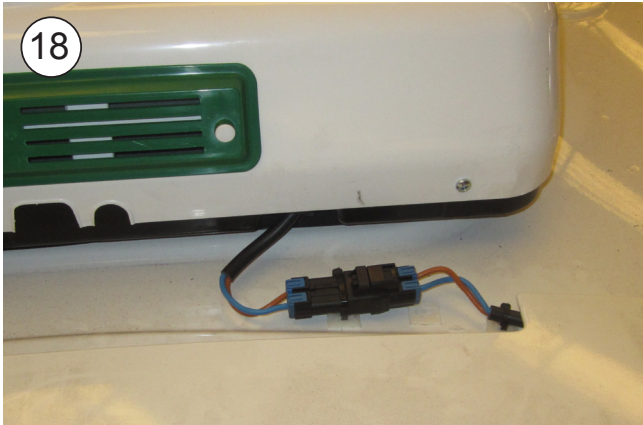
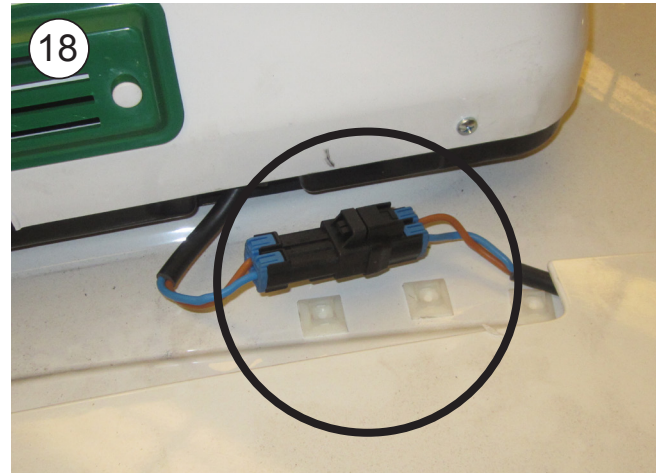

19

Aflojar soportes de spoiler, lado derecho, y pasar cableado por debajo de ellos, pegado a la esquina de la cabina y dejar soportes spoiler en posición original.



20

Fijar cableado bajo el spoiler con soportes con adhesivo y bridas de plástico.

Atención: limpiar bien la zona antes de pegar los soportes con adhesivo.



21

Sujetar cableado con soportes con adhesivo y bridas a cabina, soporte spoiler lateral y cableado original.

Atención: limpiar bien la zona antes de pegar los soportes con adhesivo.

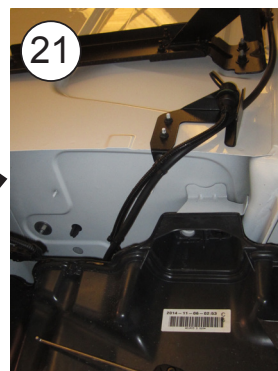
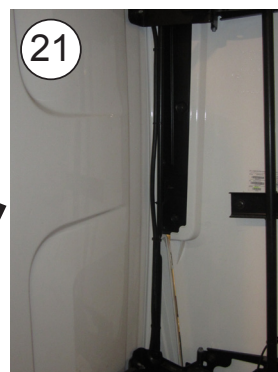

22 Abatir cabina y pasar cableado por debajo de protector (*) hacia la parte delantera de la cabina, fijándole con bridas a cable original.

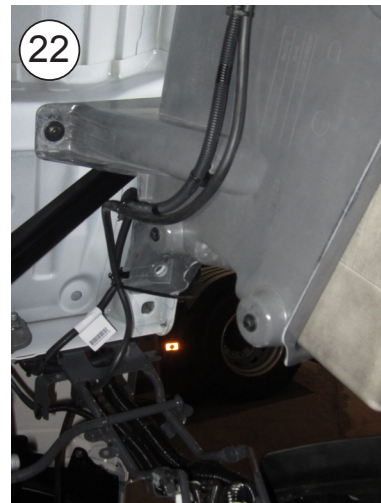
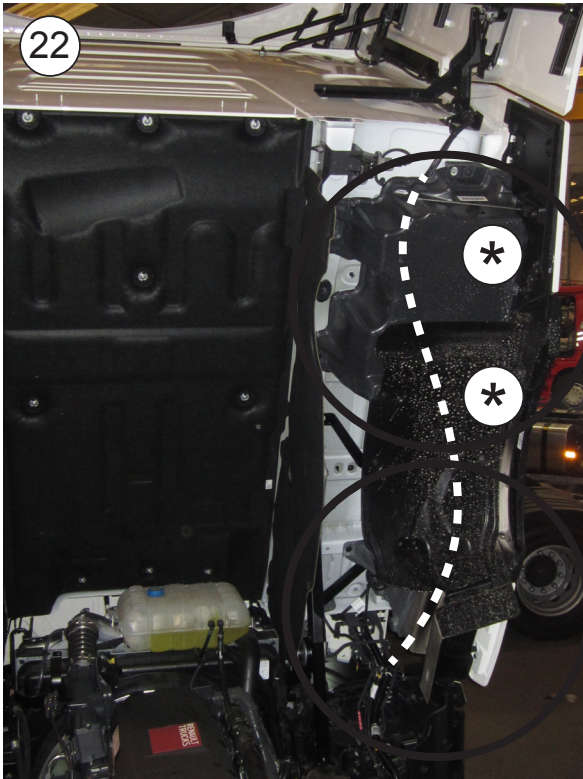

23 Dejar cabina en posición marcha y desmontar tapas de conexiones y paso de cableados originales (*).

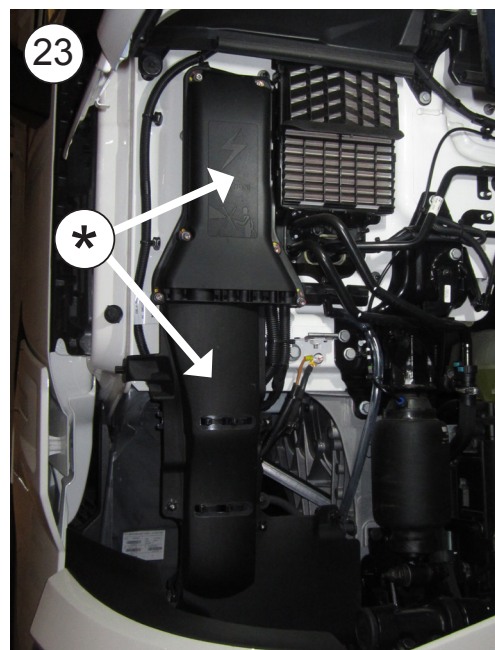

24 Conectar cableado a tomas originales de (+) y (-) pasándolo con cableados originales. Fijar fusible con brida de plástico a cableado original.

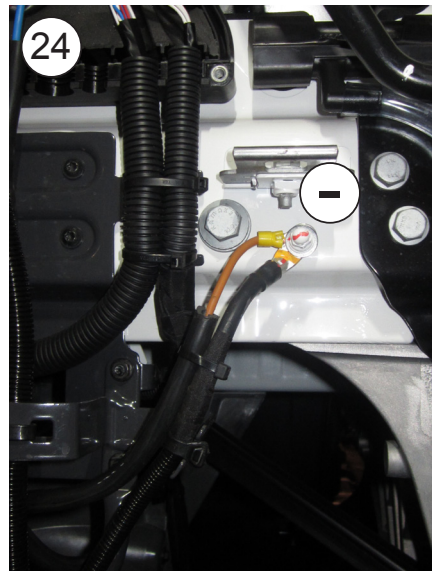
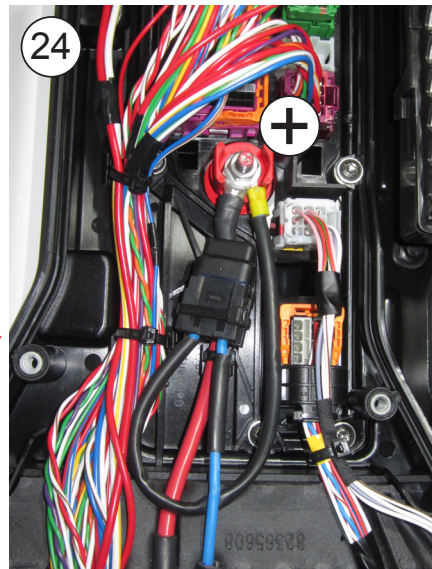
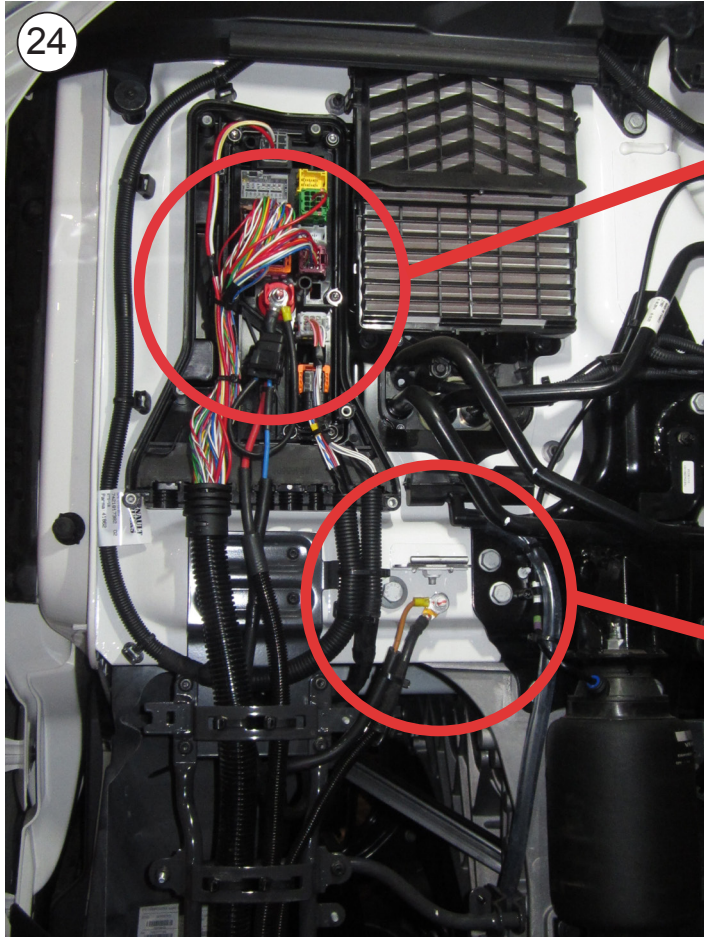

 Atención antes de poner el equipo en funcionamiento hay que esperar al menos una hora después de dejar la cabina en posición de marcha.

Esquema eléctrico

¡AVISO IMPORTANTE!

Precaución de no invertir las polaridades al conectar el equipo a la batería. Si esto sucediera la placa de mandos no se enciende y el equipo no funciona.

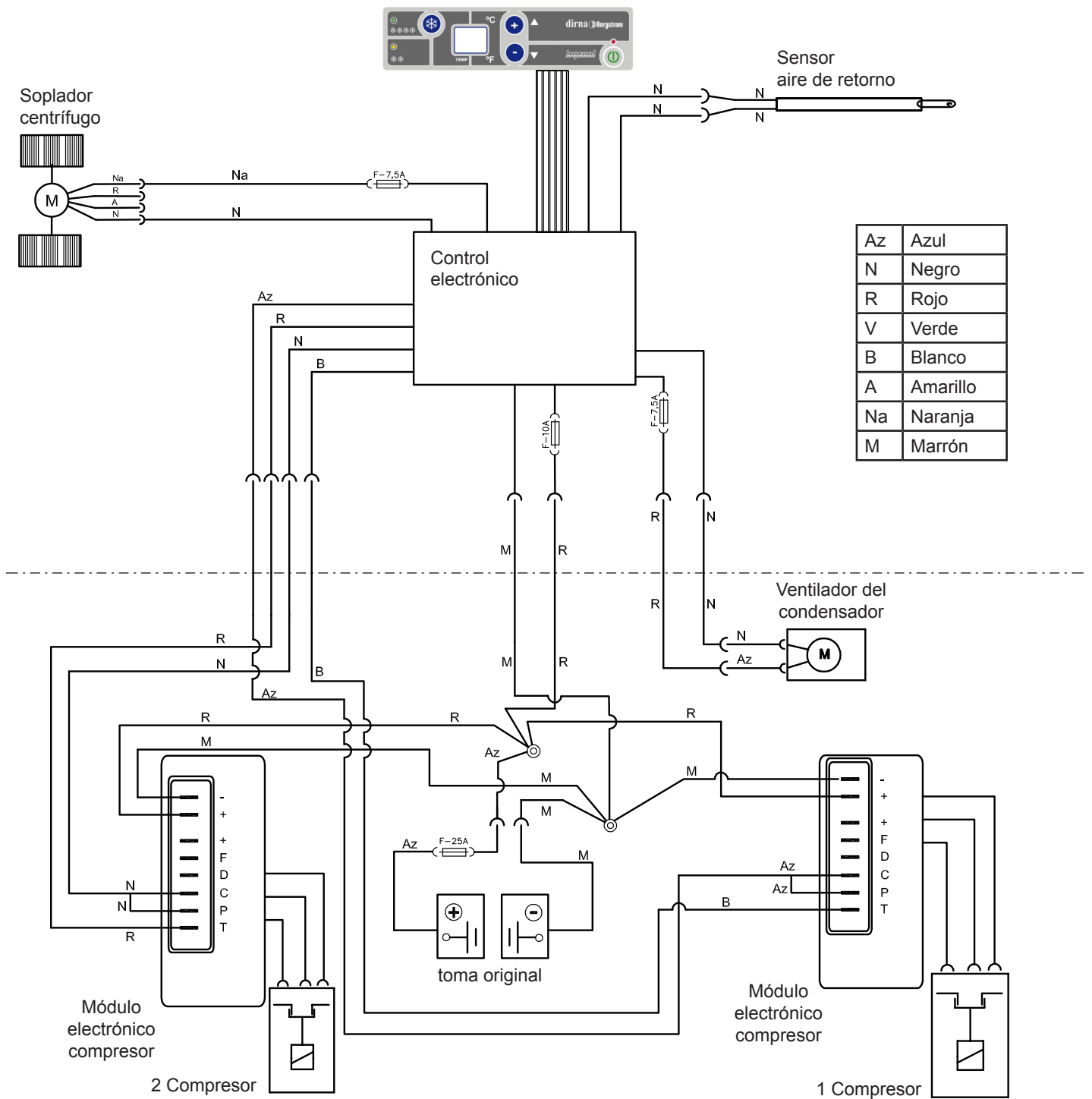

Assembly Recommendations

- Before starting assembly, please read instructions and follow them during installation process.
- Use the adequate tools for each operation.

Electricity

- Disconnect ignition key.
- Disconnect battery before starting assembly.
- Make sure electric components are securely connected, checking their correct fitting.

Warning

If the unit slants during assembly, wait for at least 60 minutes with the unit in horizontal position before starting it up.

Warning

When installing air conditioning equipment on roof, the upper cabin part must be protected with a cloth or a protective blanket to avoid possible scratches. When installing **Compact** on roof, take into account that, normally, cabins equipped with a hatch have a strong enough structure to hold equipment weight. However, if it is not the case and it is necessary to carry out a cut in the roof or, although it has a hatch, the material is not resistant enough (*if roof is made of fibre, plastic, etc...*), it is the installer who will have to decide, under his responsibility, if it is necessary to reinforce the roof to avoid possible deformations, breaks, water entries, etc., habilitating the means required to stop it from occurring.



Tools

Torx wrenches set
 Allen wrenches set
 Open-jawed spanner 10, 13, 14
 Scissors
 Flexo-meter







Documentation included

Mounting instructions	1001261110
Parts list	220RE00215

Symbology

-  Fragile
-  Beware of cuts!
-  Electrical hazard

Warnings

-  The installing personnel must have a sufficient training in vehicles air conditioning.
-  **dirna Bergstrom, s.l.** shall not be responsible for breakdowns or damages coming from an inadequate handling or installation of the equipment or from modifications and substitutions carried out without our express and written authorisation.
-  **Equipment pre-charged with refrigerating gas, R-134a. (Do not handle refrigerating gas circuit).**
-  Please see product **warranty procedure** included in **Troubleshooting diagnosis**.
-  Please see equipment **User's Guide** for its correct functioning of the remote control and control panel.
-  Once installation is finished, the following documents must be handed over to the user: **User's Guide, Warranty and Troubleshooting Diagnosis**.

 Mount the front air input grille before starting assembly.



1 Take down the original console, pulling on the end of the lights to access the fastening screws.
If LEDs are fitted (*), pull on them to remove.



2 Take down the hatch by removing the fastening screws (disconnect wire clamp (*) in electrical hatch).



3 Clean any dirt and grease from the hatch area before attaching the EPDM seal. Attach the 30x25 EPDM seal around the rim of the hatch gap.



4 **HOW TO CUT EPDM GASKET TO AVOID WATER FILTRATION INTO THE CABIN**

A- Glue gasket, keeping 100 mm of protection paper at each side.

B- Remove the two pieces of paper.

C- Glue by pressing both ends.

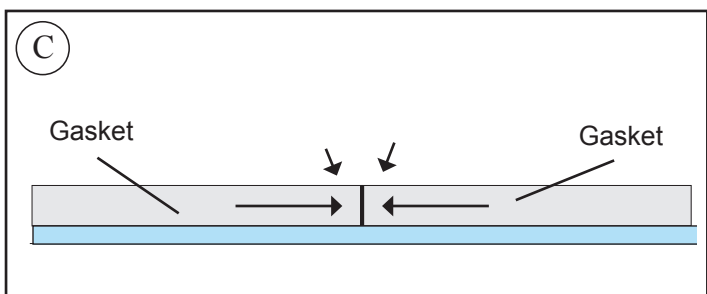
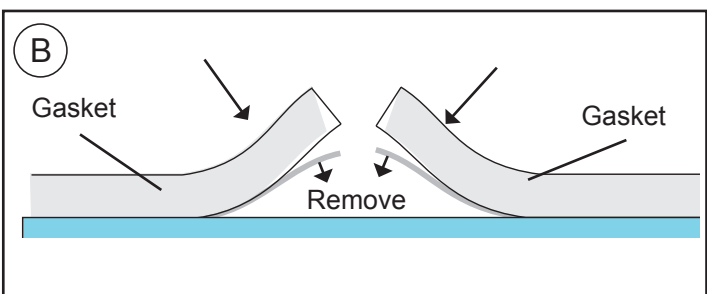
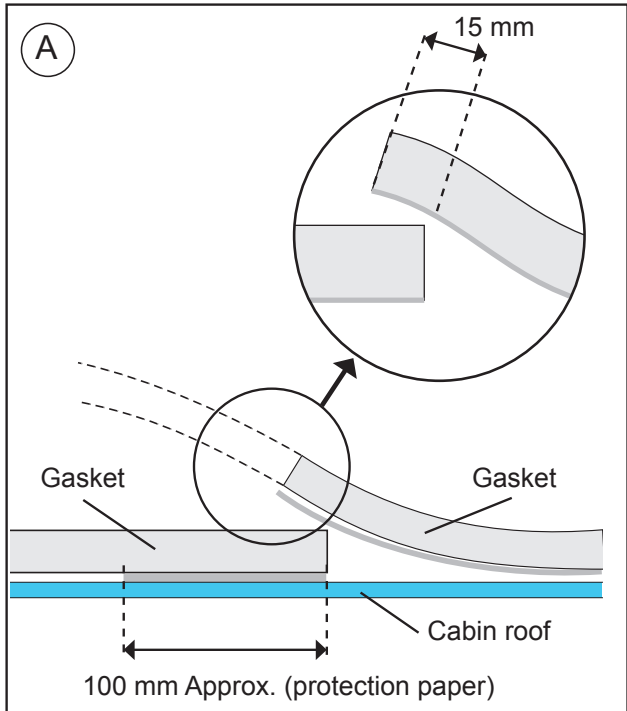

5 **Outside cabin:** Position **Cooltronic** in sun hatch hole.
Caution: When positioning the unit above the hatch gap, check that the wastewater run-offs are not blocked by the EPDM seal.

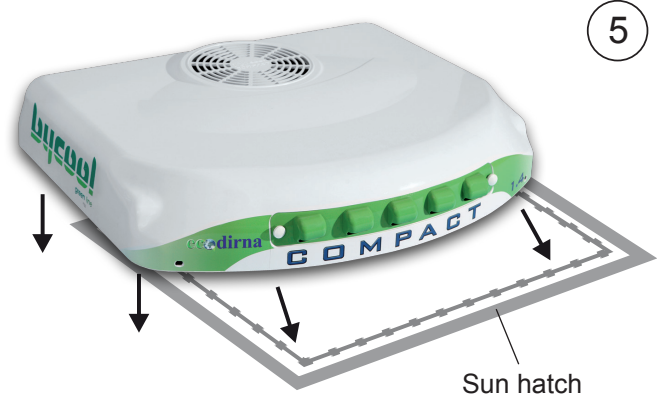

6 To place the air duct top side at the softer part of the base.



7 Mount washers in the separators as shown.

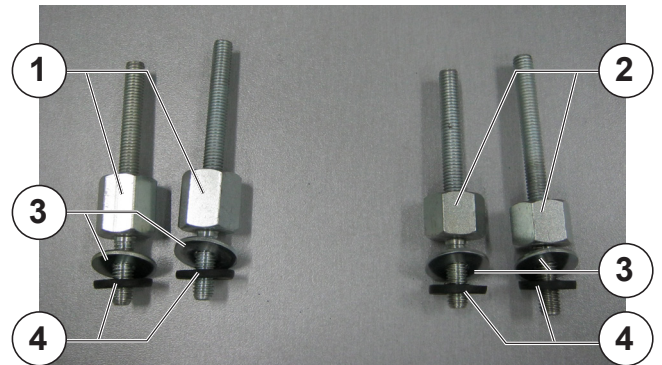

- 1.- 22 mm separator
- 2.- 17 mm separator
- 3.- Ø 8 Flat wide-rimmed washer
- 4.- Ø 20 x Ø 7 x 3 mm rubber washer

8 Mount washers in the separators as shown.

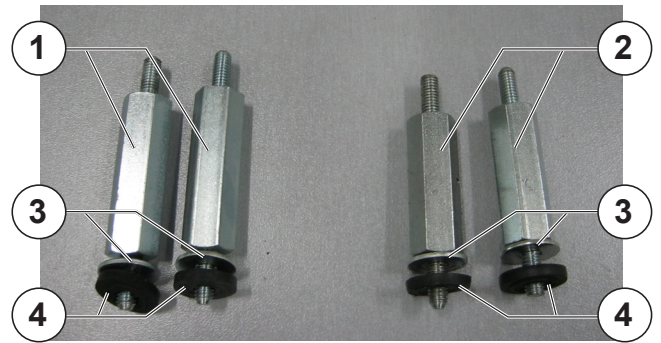

- 1.- 50 mm separator
- 2.- 43 mm separator
- 3.- Ø 8 Flat wide-rimmed washer
- 4.- Ø 18 x Ø 6 x 3 mm rubber washer

9 Montar y apretar separadores teniendo en cuenta la posición según sus medidas.





- 1.- 22 mm M8 Separator
- 2.- 17 mm M8 Separator
- 3.- 50 mm M6 Separator
- 4.- 43 mm M6 Separator

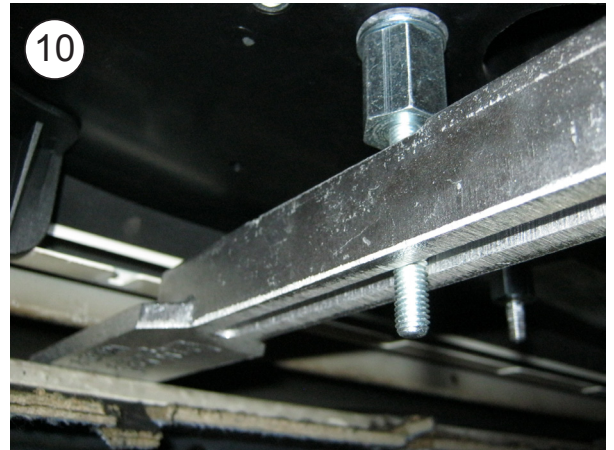

- 1.- 22 mm M8 Separator
- 2.- 17 mm M8 Separator
- 3.- 50 mm M6 Separator
- 4.- 43 mm M6 Separator

10 Introduce the mounts on M8 studs underneath the upholstery. Position (4) Ø8 wide-rimmed flat washers and (4) M8 self-locking nuts without completely tightening.



 **Caution:** Take care not to catch the hatch cabling.



11 Connect the return air sensor 2-way box, the blower 4-way box and the electronic control cable connection 8-way box.

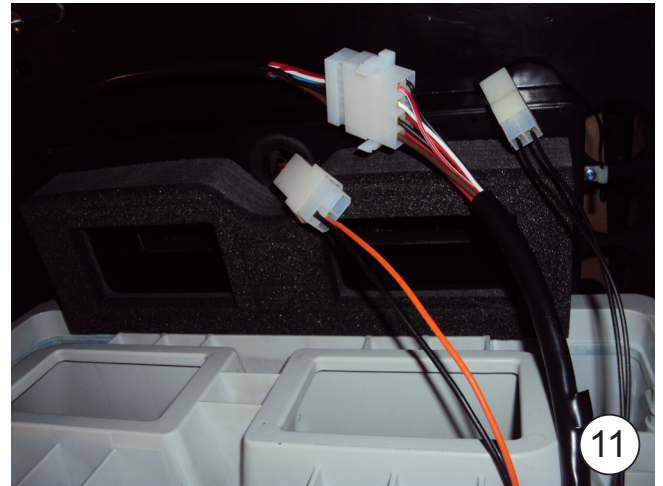

12 Mount the air distribution interior panel with (4) hexagons, taking into account the position in accordance with the measurements.

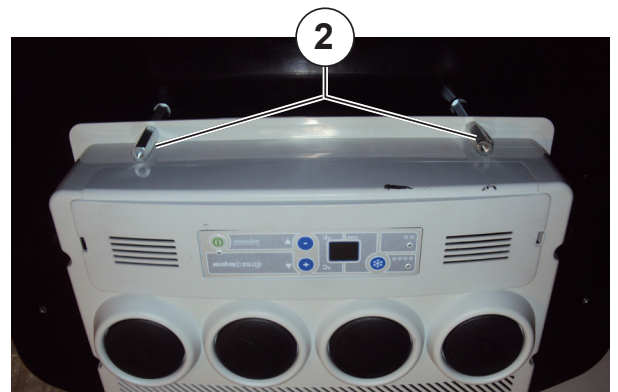
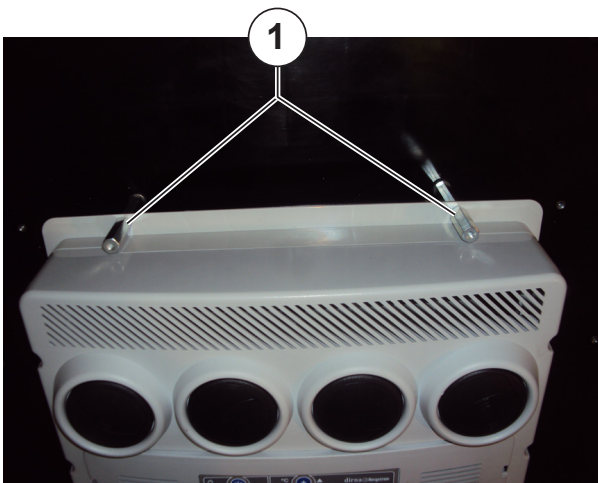

- 1.- 50 mm separator in the front section
- 2.- 43 mm separator in the rear section

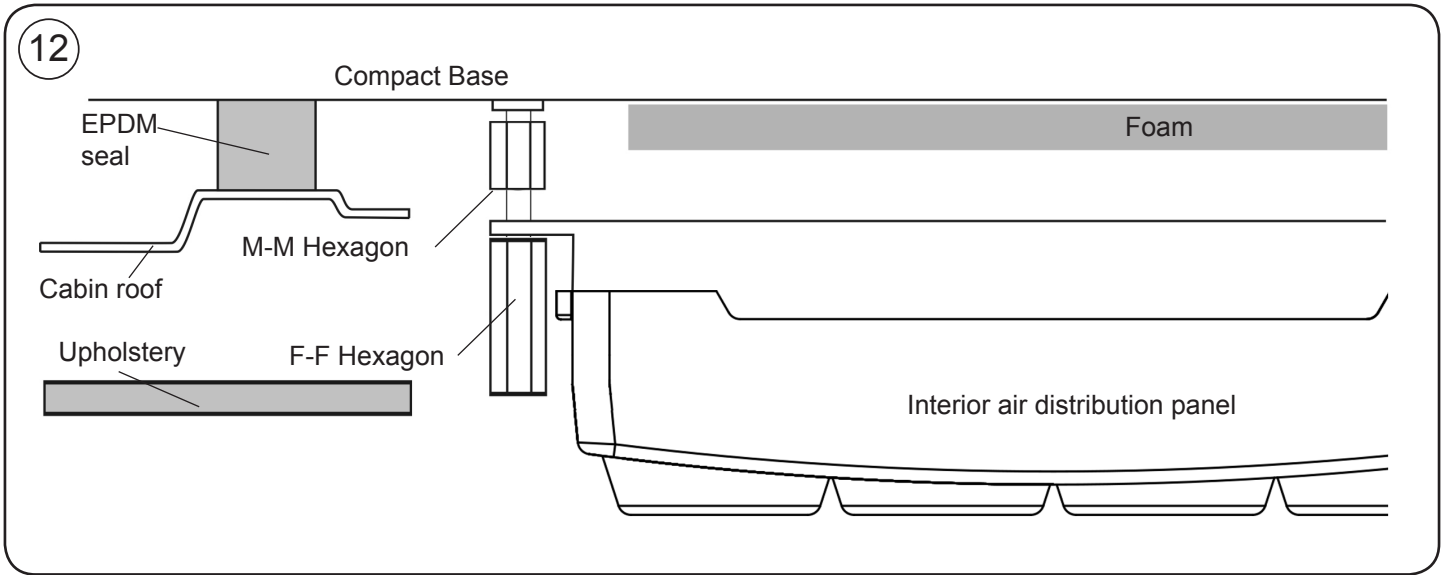

13 Mount the console using (4) M6x16 screws and align the unit until the console coincides in the part of the upholstery where the original console was mounted.



14 Once aligned, take down the console and tighten the mounts until they come up against the hexagons.

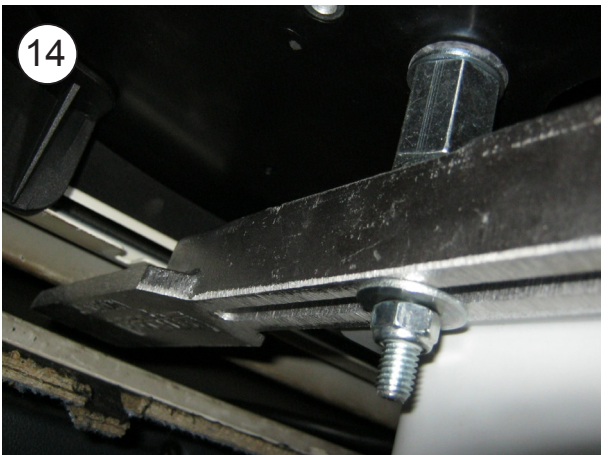

15

Check on the outside that the unit's run-offs are free and do not interfere with the EPDM seal.

16

Return the console using the M6x16 screws, tightening until it comes up against the hexagons.



17

Connect the lights and fit them by pressing on the console.



EXPLODED SIDE VIEW TO SUPPORTS FASTENING

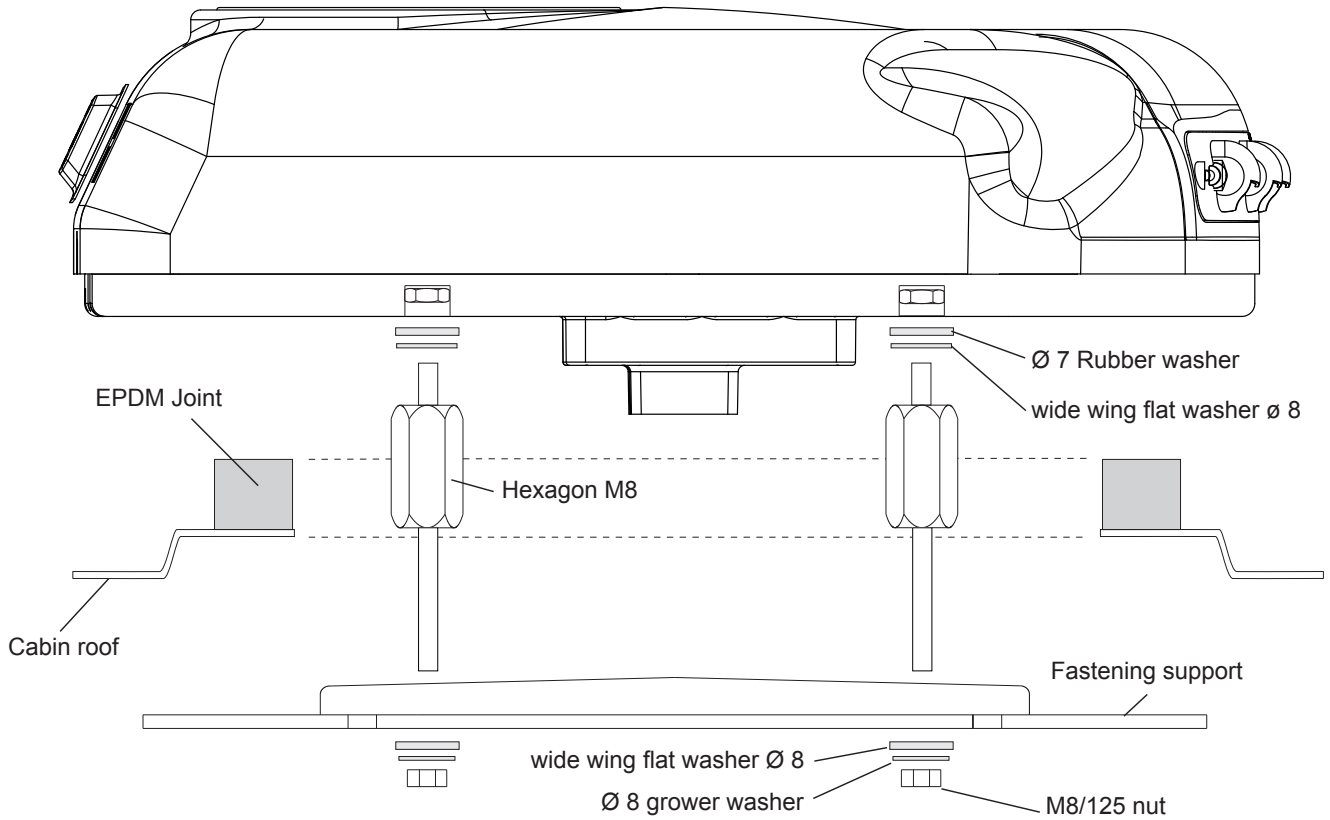

EXPLODED REAR VIEW TO CONSOLES FASTENING

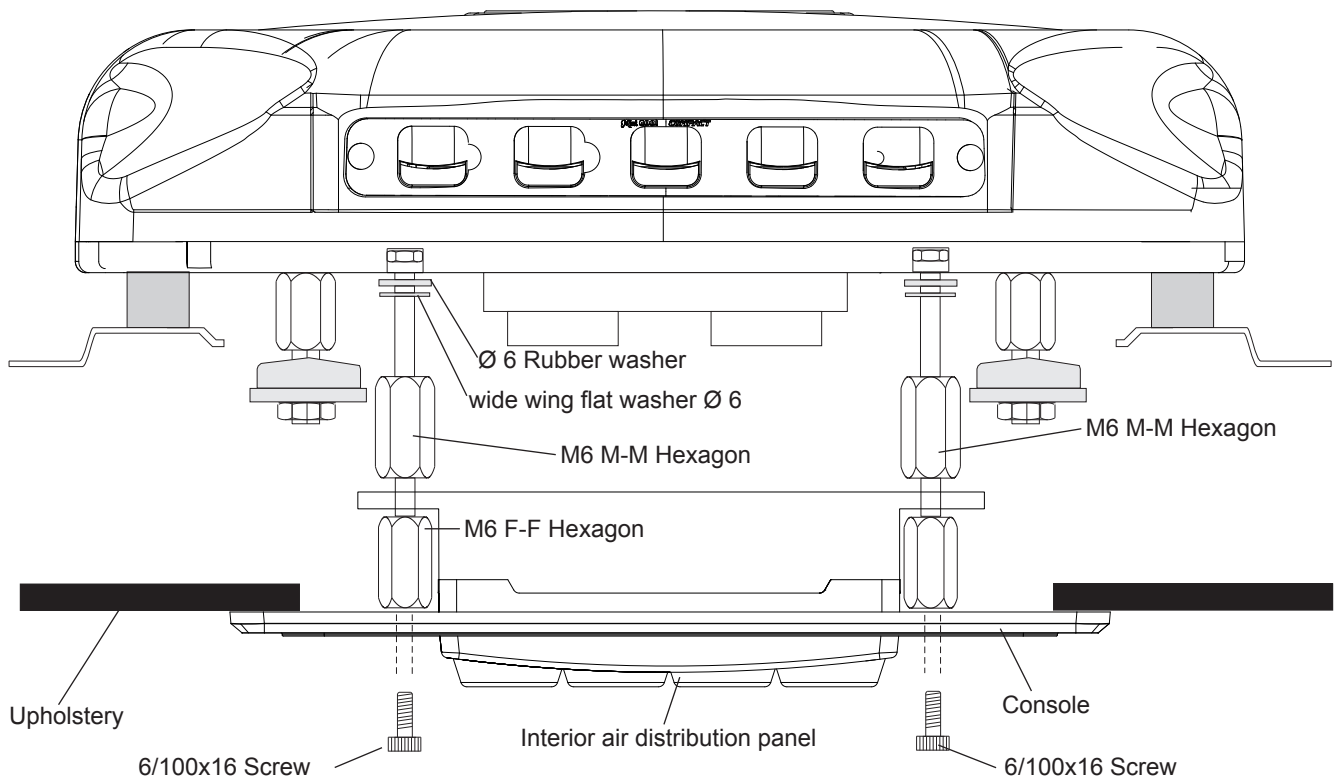

18 Pass the power cable underneath the spoiler and connect to the unit, secure the connection wire clamps to the roof with mounts with adhesive and plastic flanges.

Caution: clean the area thoroughly before attaching the mounts with adhesive.

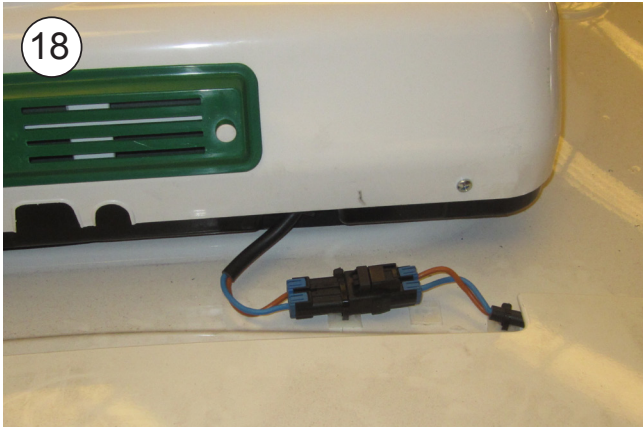
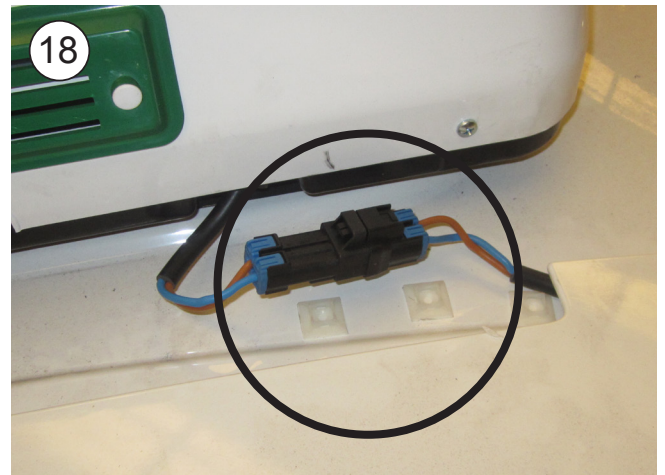

19 Loosen the right side spoiler mounts and pass the wiring underneath, next to the corner of the cabin, and leave the spoiler mounts in original position.



20 Secure the wiring underneath the spoiler with the mounts, with adhesive and plastic flanges.

Caution: clean the area thoroughly before attaching the mounts with adhesive.



21 Secure the wiring with mounts with adhesive and flanges to the cabin, side spoiler mount and original wiring.

Caution: clean the area thoroughly before attaching the mounts with adhesive.

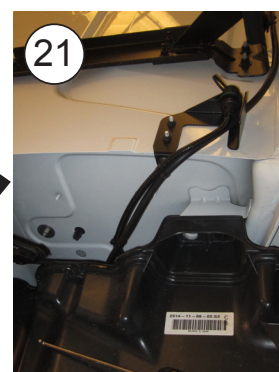

22 Tilt the cabin and run the wiring underneath the protector (*) to the front part of the cabin, securing to the original wires with flanges.

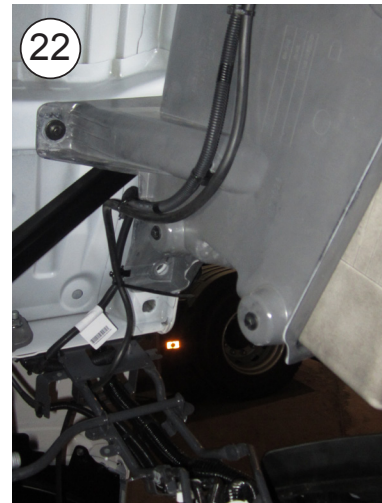
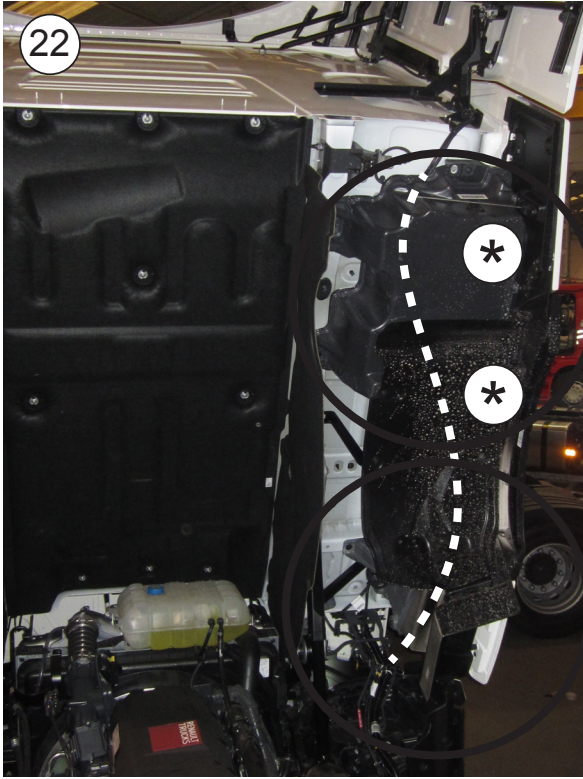

23 Leave the cabin in operating position and take down the original wiring run and connections covers (*).

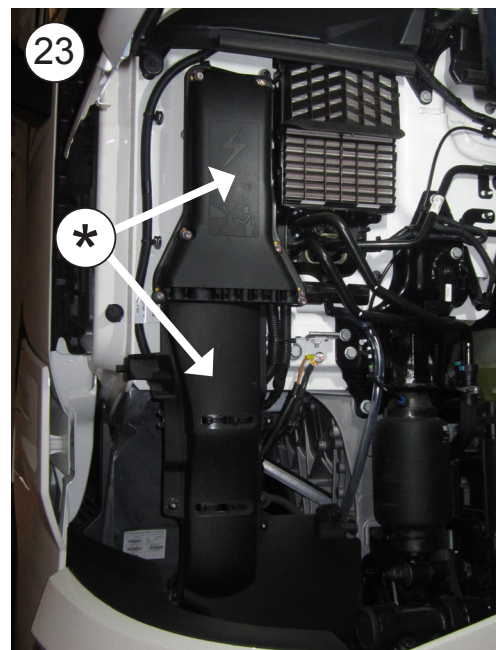

24 Connect the wires to the original (+) and (-) connection points, passing them with the original wiring. Secure the fuse to the original wiring using plastic flanges.

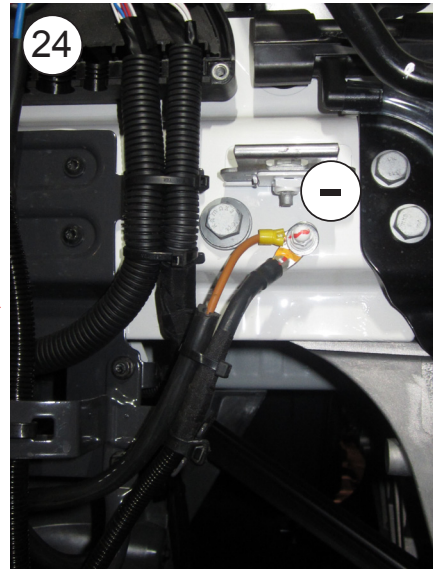
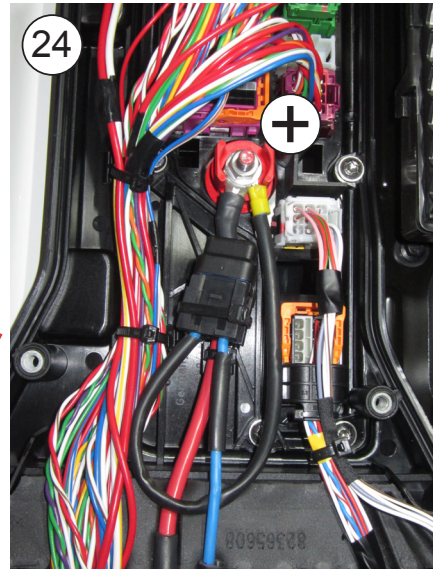
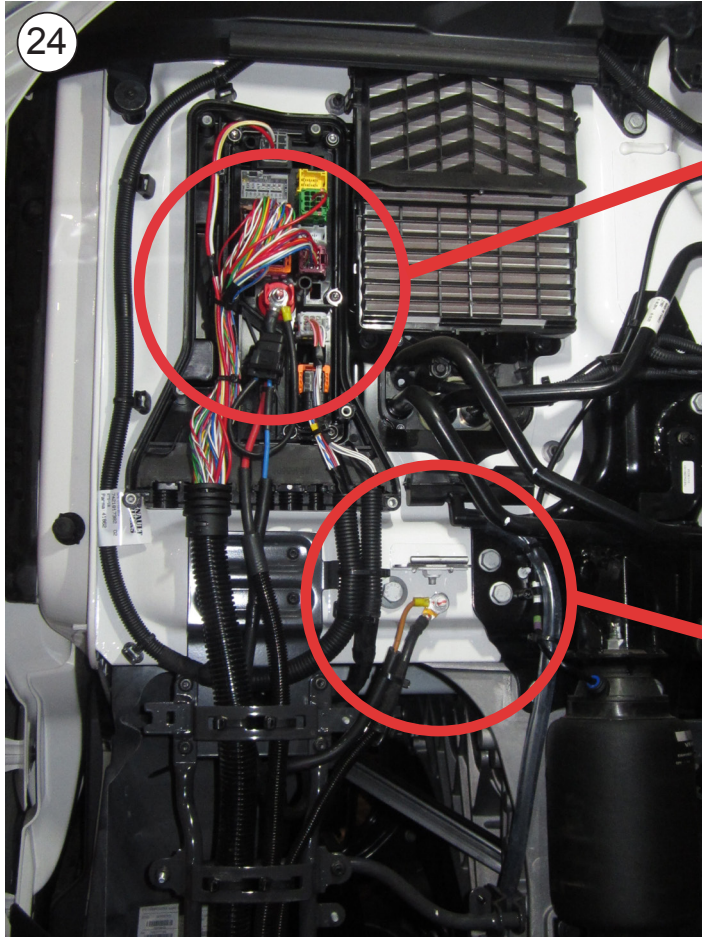

 **Caution:** The unit must not be started up until at least one hour after leaving the cabin in operating position.

Wiring diagram

IMPORTANT NOTE!

Take care not to invert polarities when connecting the unit. If this happens, the plate does not come on and the unit does not work.

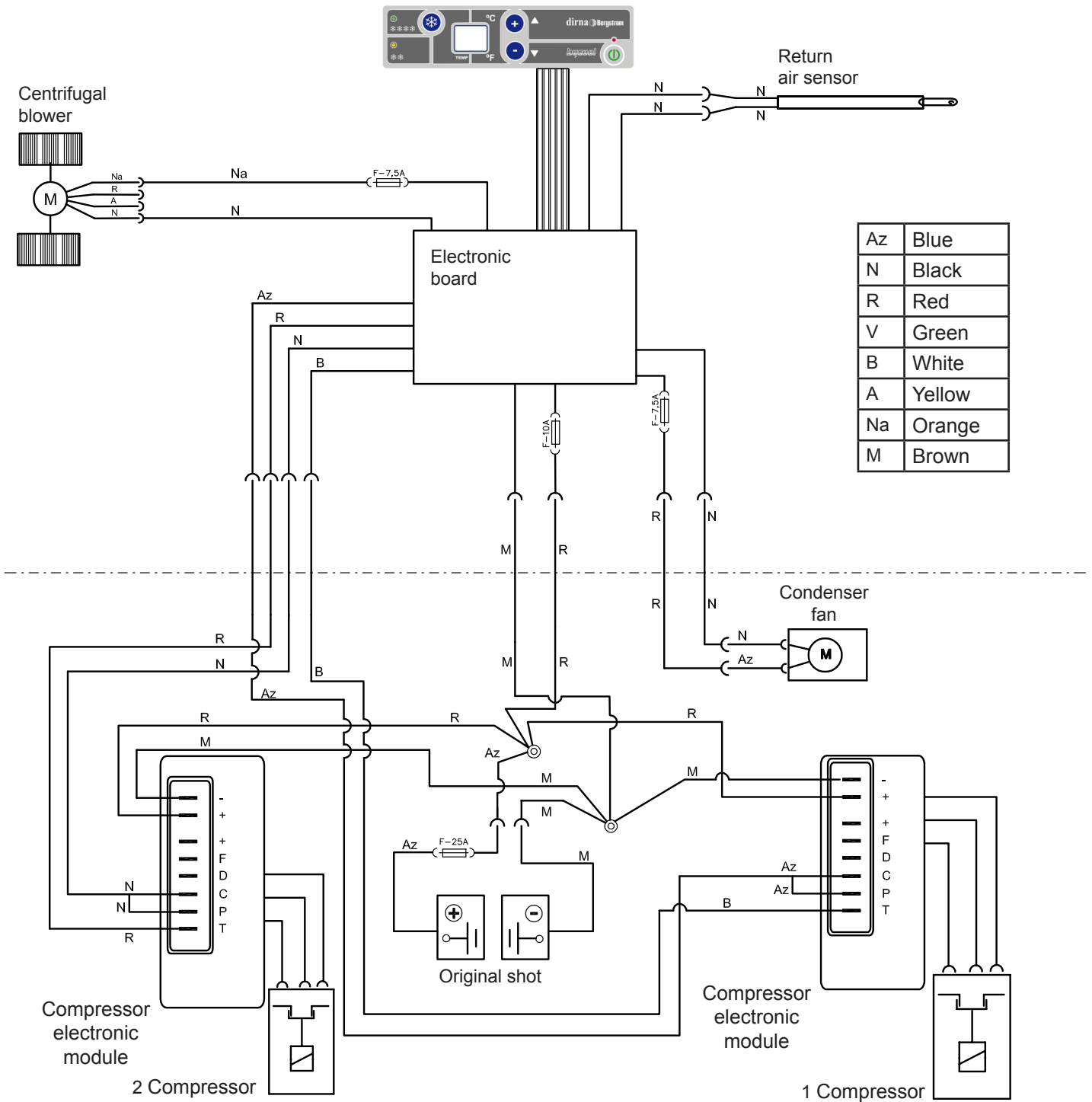

Recommandations Pour Le Montage

- Avant de commencer le montage de l'appareil, prière de lire les instructions et de les suivre attentivement.
- Utiliser les outils convenant à chaque opération.

Electricity

- Déconnecter la clé de contact.
- Déconnecter la batterie avant de commencer le montage.
- Vérifier le câblage des composants électriques et leur correcte installation.

Attention

Si pendant le montage l'équipement est incliné, il faudra attendre au moins 60 minutes avant de le mettre en marche une fois qu'il aura été remis sur sa position horizontale.

Attention

Lors de l'installation de l'appareil d'air conditionné sur le toit, il faudra protéger la partie supérieure de la cabine avec un linge ou une couverture de protection afin d'éviter les éventuelles égratignures.

Durant l'installation du **Compact**, tenir compte du fait que normalement les cabines pourvues d'écouille possède une structure suffisamment solide pour supporter le poids de l'appareil. Cependant, si ce n'est pas le cas et qu'il est nécessaire de découper le toit ou même si disposant d'écouille, la structure n'est pas suffisamment rigide (si elle était en fibre, plastique, etc.) il appartiendra à l'installateur de décider s'il faut renforcer le toit pour éviter toute déformation, rupture ou voie d'eau, etc., et prendre les mesures nécessaires à cet effet.

Outils

Jeu de clés Torx

Jeu de clés Allen

Clé fixe 10, 13, 14

Ciseaux

Mètre

Documentation included

Instructions de montage	1001261110
Liste de rechanges	220RE00215

Symbologie



Fragile



Attention aux coupures !



Risque électrique

Garantie



L'installateur devra posséder la formation pertinente en air conditionné sur véhicules.



dirna Bergstrom, s.l., ne sera pas responsable des dommages ou des bris dérivés d'une installation ou d'une manipulation incorrecte ni des modifications réalisées sans autorisation expresse par écrit.



Appareil pré-chargé de gaz réfrigérant R-134. (Ne pas manipuler le circuit de gaz réfrigérant).



Voir la **procédure de garantie** du produit au **Diagnostic de problèmes**.



Voir le **Guide de l'Usager** de l'appareil pour le fonctionnement correcte de la télécommande et du tableau de commande.



Après l'installation, vous devez fournir à l'utilisateur: **Manuel d'utilisation, garantie et diagnostic de pannes**.

 Avant de commencer le montage, monter la grille d'entrée d'air avant.



1 Démontez la console d'origine et tirez sur l'extrémité des lumières pour accéder aux vis de fixation.
Si des leds sont installés (*), il faudra les démonter en les tirant.



2 Démontez ensuite l'écouille en retirant la vis de fixation de cette dernière (dans une écoutille électrique, déconnecter la borne (*)).



3 Nettoyer la zone de l'écouille en cas de saleté et de présence de graisse adhéree avant de coller le joint EPDM. Coller le joint EPDM 30x25 sur le bossage du contour du creux de l'écouille.



4 **COMMENT COUPER LE JOINT EPDM POUR EVITER LES FILTRATIONS DANS LA CABINE**

A- Coller le joint en maintenant une protection en papier de 100 mm de chaque côté.

B- Retirer les deux morceaux de papier.

C- Coller en faisant pression sur les deux extrémités.

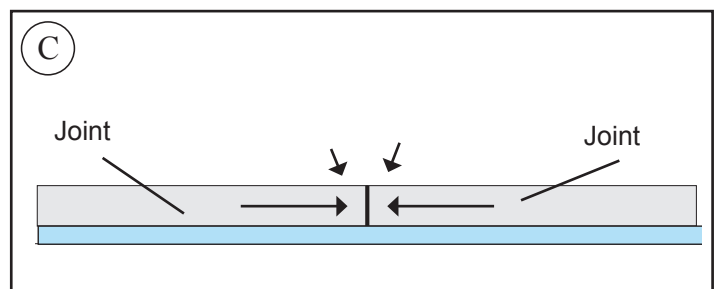
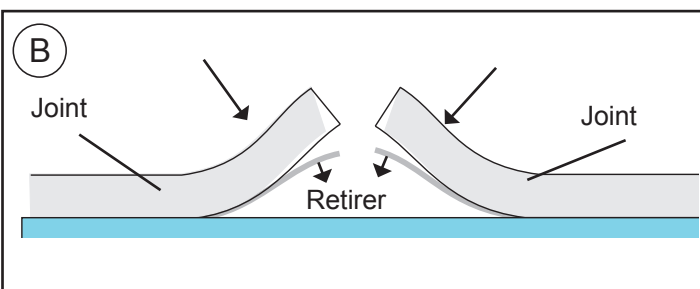
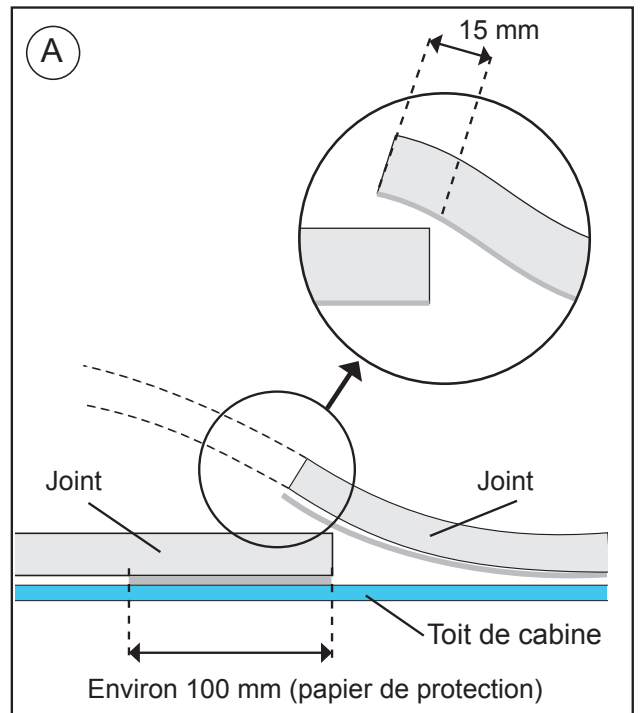

5 **Extérieur cabine** : placer l'équipement dans le creux de l'écouille.

Attention : avant de placer l'équipement dans le creux de l'écouille, il faut vérifier que les sorties d'écoulement ne soient pas bouchées par le joint EPDM.

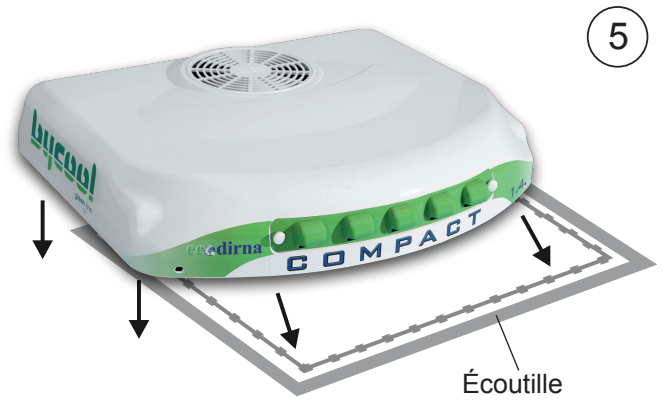

6 Placer le couplage canalisateur en caoutchouc mousse en laissant la partie la plus molle sur la base de l'équipement.



7 Monter les rondelles dans les séparateurs, tel que cela est indiqué.

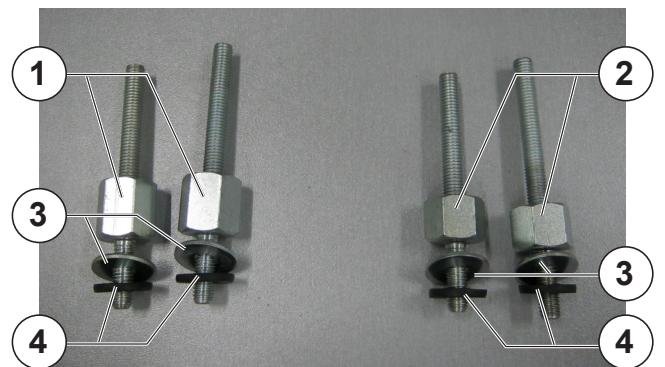

- 1.- Séparateur 22 mm
- 2.- Séparateur 17 mm
- 3.- Rondelle plate Ø 8 surface large
- 4.- Rondelle caoutchouc Ø 20 x Ø 7 x 3 mm

8 Monter les rondelles dans les séparateurs, tel que cela est indiqué.

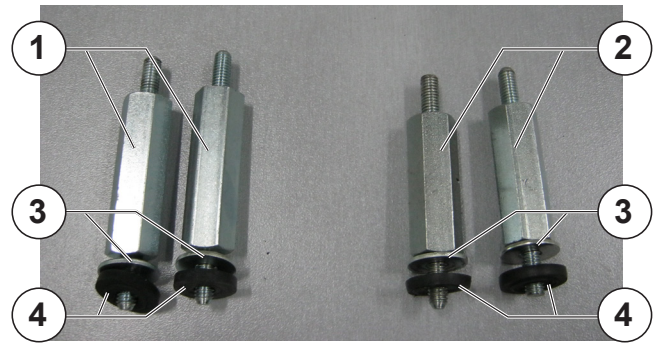

- 1.- Séparateur 50 mm
- 2.- Séparateur 43 mm
- 3.- Rondelle plate Ø 8 surface large
- 4.- Rondelle caoutchouc Ø 18 x Ø 6 x 3 mm

9 Monter et serrer les séparateurs en considérant la position selon les mesures.



- 1.- Séparateur M8 22 mm
- 2.- Séparateur M8 17 mm
- 3.- Séparateur M6 50 mm
- 4.- Séparateur M6 43 mm

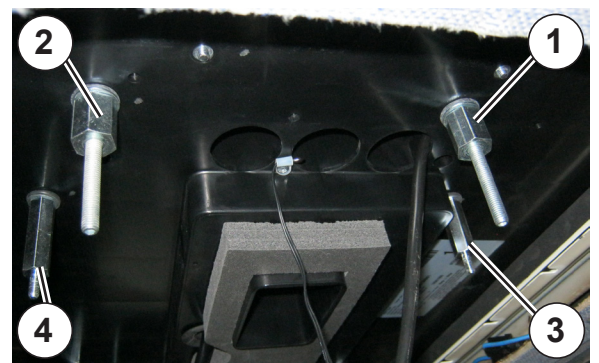

- 1.- Séparateur M8 22 mm
- 2.- Séparateur M8 17 mm
- 3.- Séparateur M6 50 mm
- 4.- Séparateur M6 43 mm

- 10** Introduire des supports dans les goujons M8 sous la tapisserie. Placer (4) rondelles plates Ø8 surface large et (4) écrous M8 autobloquants sans serrer totalement.

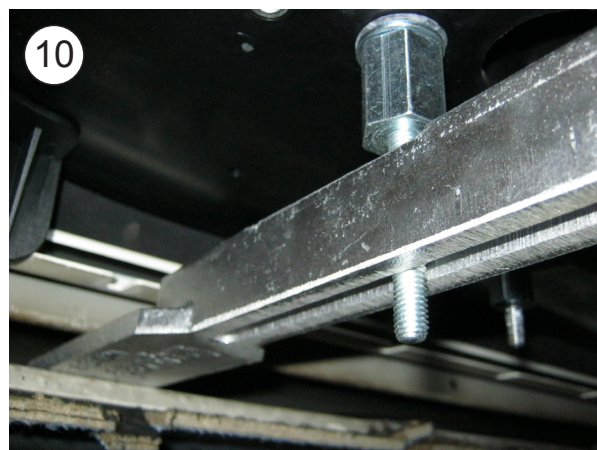

Attention : attention de ne pas pincer le câblage de l'écoutille.



11

Connecter le boîtier à 2 voies du capteur de l'air de retour, le boîtier à 4 voies du souffleur et celui à 8 voies de connexion des câblages du contrôle électronique.

**12**

Monter le panneau intérieur de distribution d'air avec (4) hexagones en considérant la position selon les mesures.

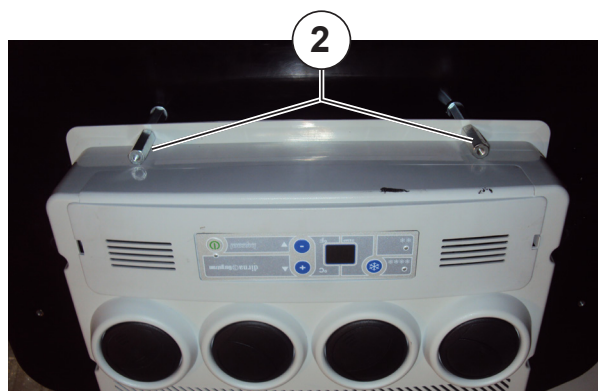
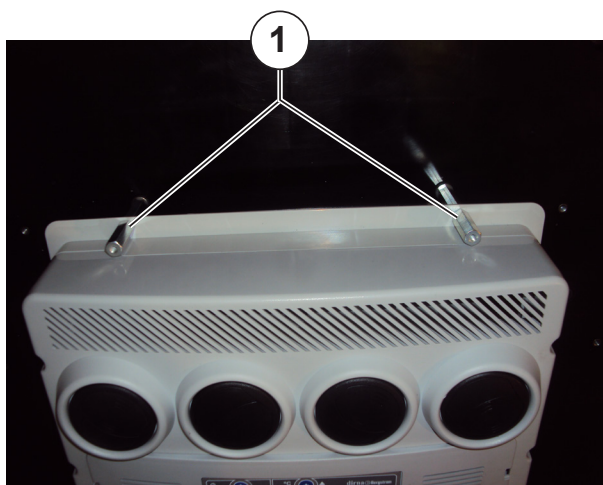

- 1.- Séparateur 50 mm sur la partie avant
- 2.- Séparateur 43 mm sur la partie arrière

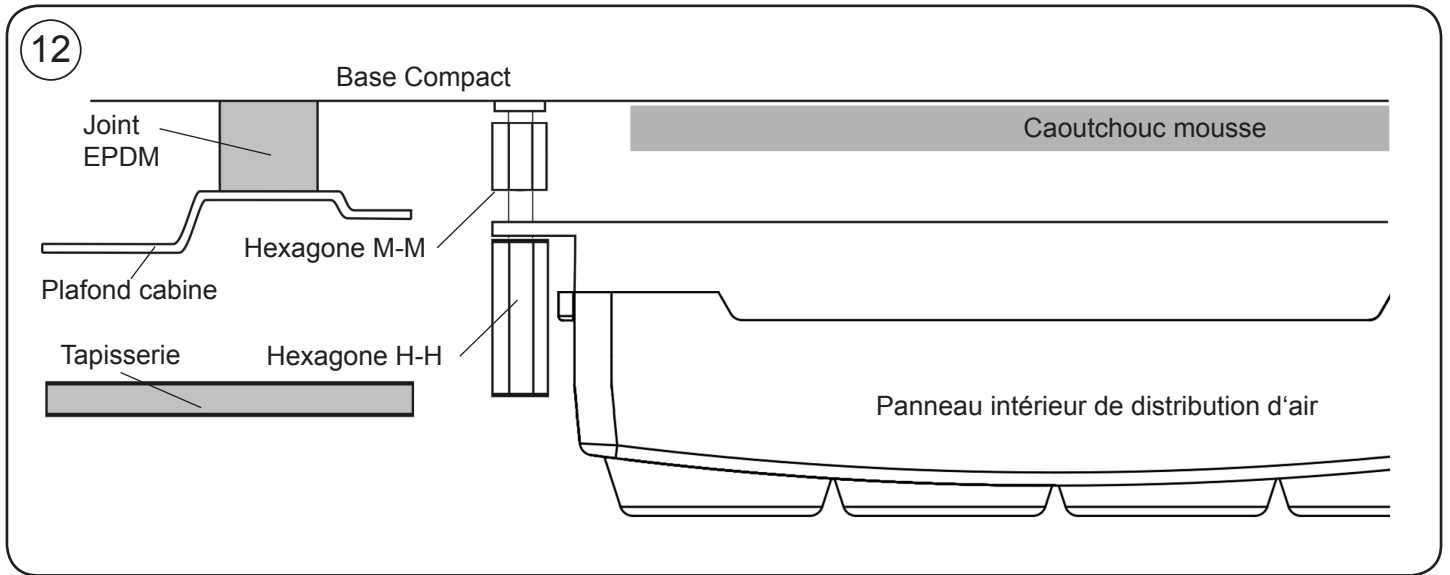

13

Monter la console avec (4) vis M6x16 et centrer l'équipement jusqu'à faire coïncider la console à l'emplacement de la tapisserie où la console originale était installée.



14

Une fois centrée, démonter la console et serrer les supports jusqu'à ce qu'ils atteignent la butée avec les hexagones.

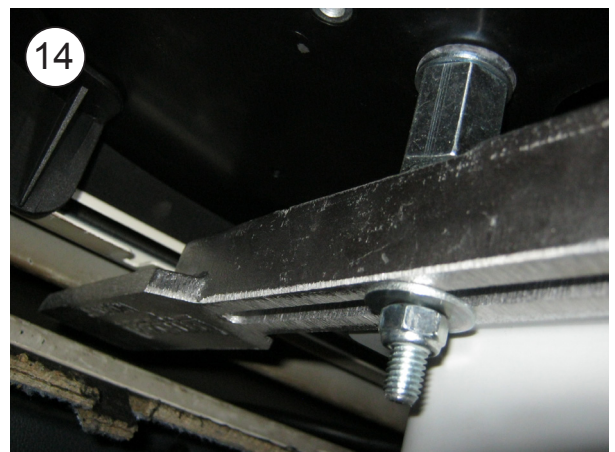

15

Vérifier de l'extérieur que les écoulements de l'équipement soient libres et qu'ils n'interfèrent pas avec le joint EPDM de l'équipement.

16

Monter à nouveau la console avec les vis M6x16 en serrant jusqu'à atteindre les hexagones.

**17**

Connecter les lumières et les emboîter en exerçant une pression sur la console.



VUE EXPLOSÉE JUSQU'À LA FIXATION DES SUPPORTS DE FIXATION

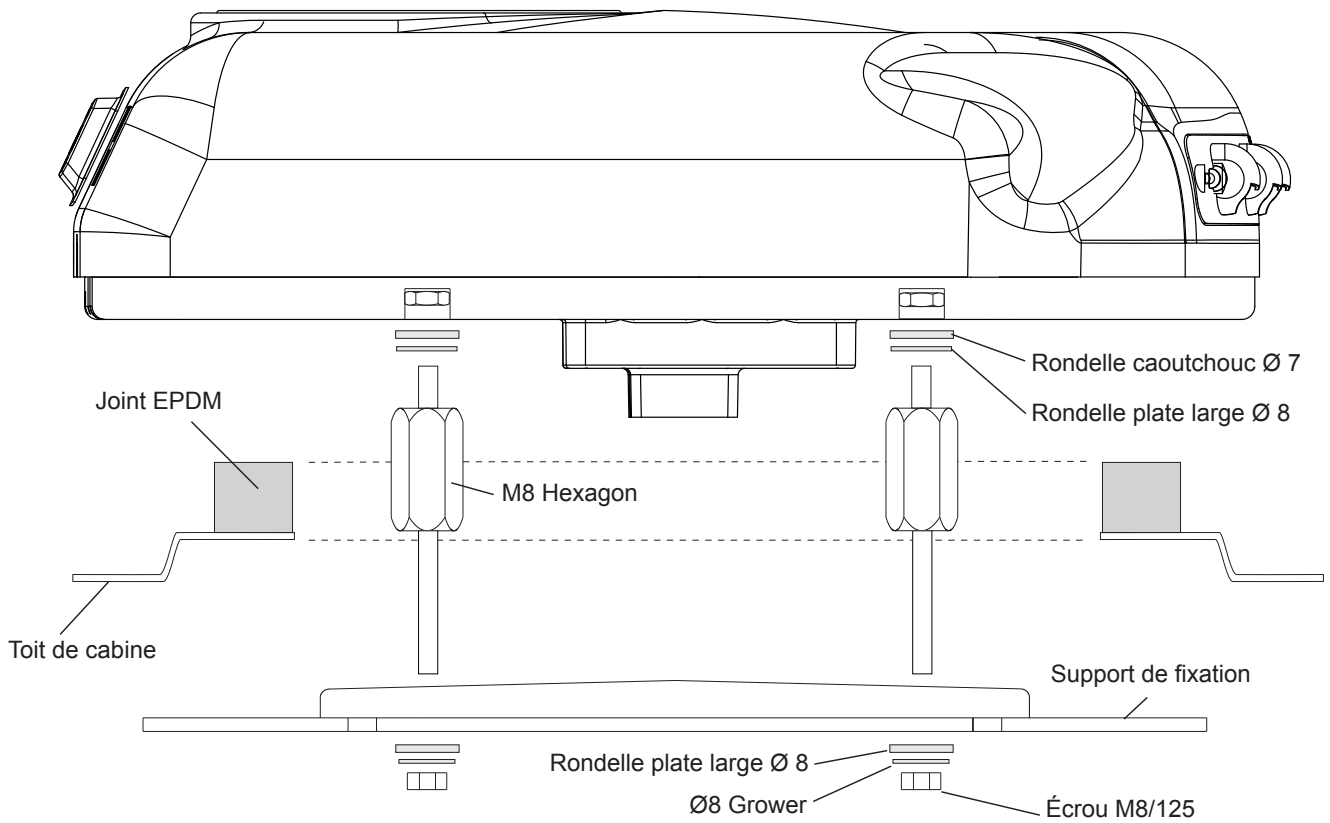

VUE EXPLOSÉE JUSQU'À FIXATION DES CONSOLES

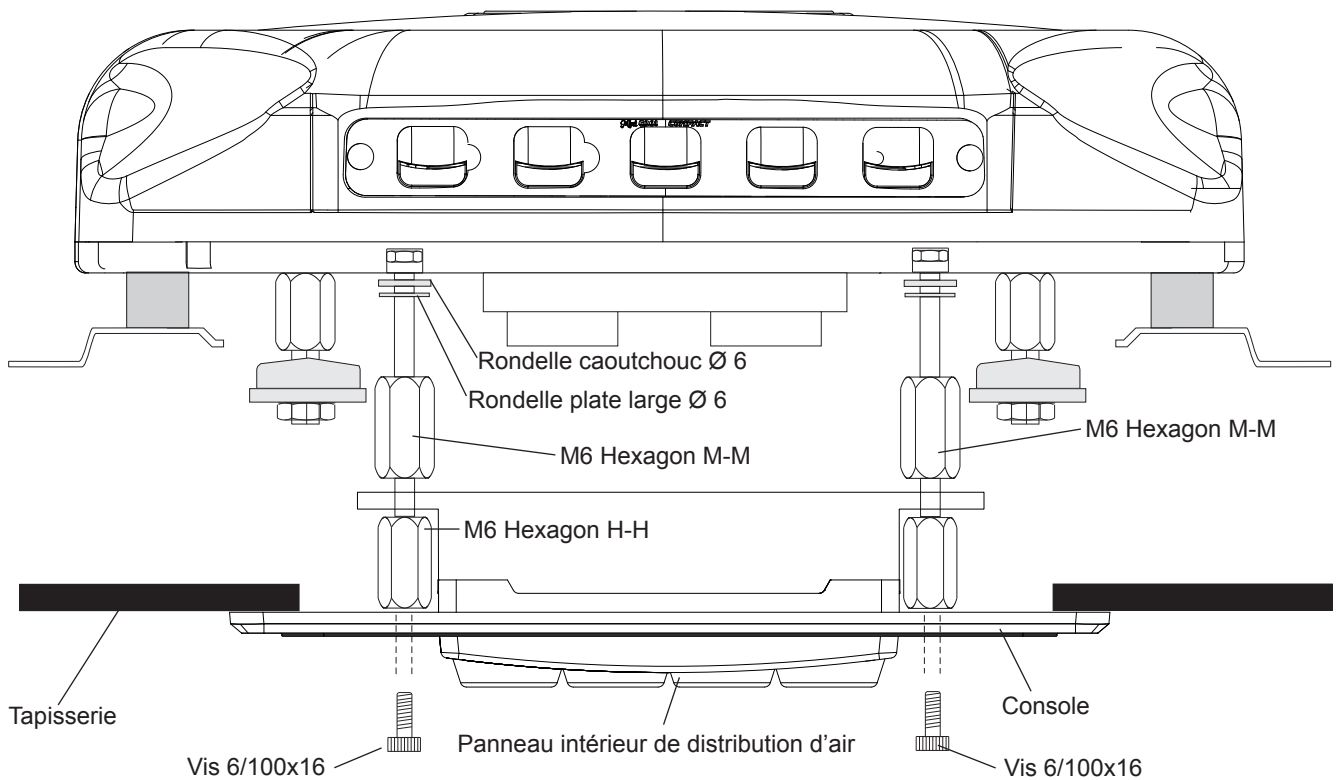

18

Passer le câblage d'alimentation sous le spoiler et connecter à l'équipement. Fixer les broches de connexion au plafond avec des supports et de l'adhésif et des brides en plastique.

Attention : nettoyer correctement la zone avant de coller les supports avec de l'adhésif.

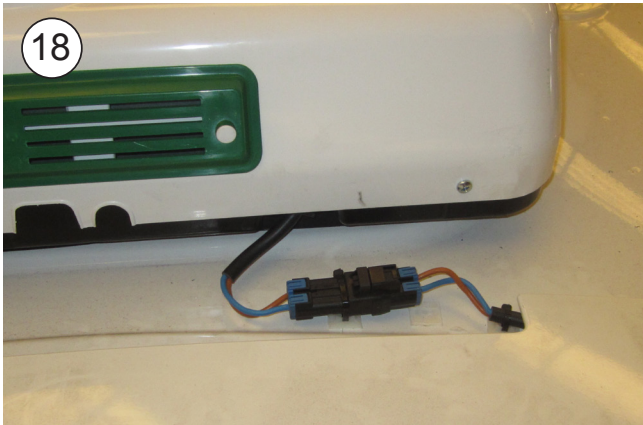
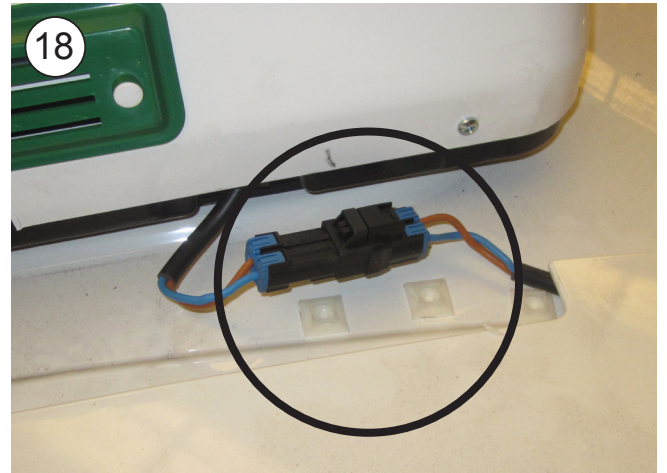

19

Desserrer les supports du spoiler, côté droit, et passer le câblage sous ces derniers, collé à l'angle de la cabine, puis laisser les supports spoiler sur la position d'origine.



20

Fixer le câblage sous le spoiler avec des supports et de l'adhésif et des brides en plastique.

Attention : nettoyer correctement la zone avant de coller les supports avec de l'adhésif.



21

Fixer le câblage avec des supports et de l'adhésif et des brides à la cabine, support spoiler latéral et câblage d'origine.

Attention : nettoyer correctement la zone avant de coller les supports avec de l'adhésif.

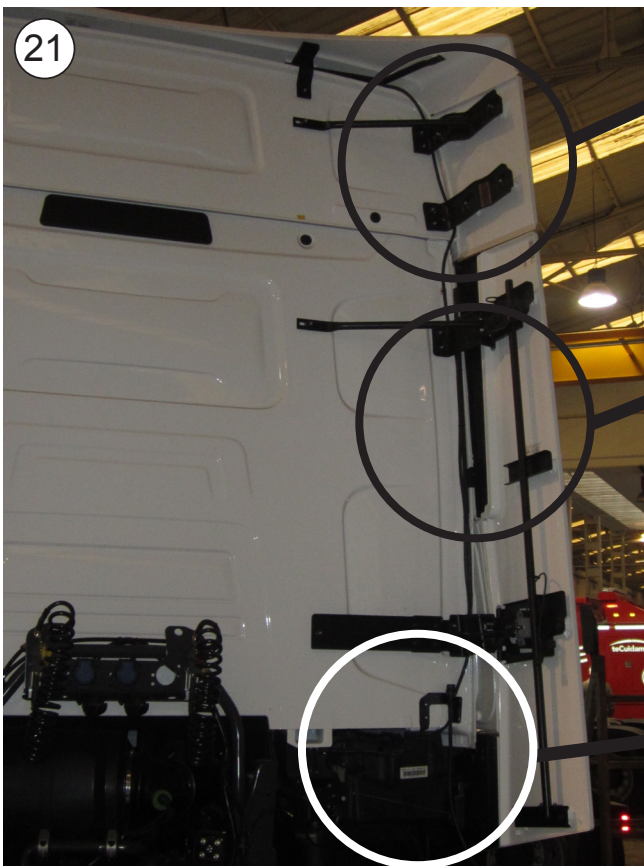
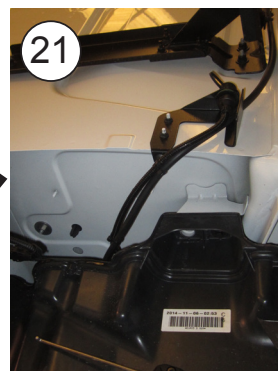
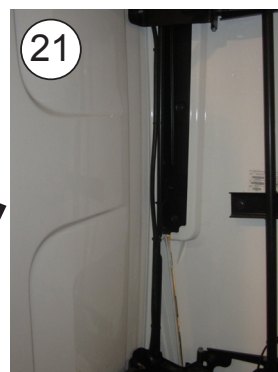

22

Abattre la cabine et passer le câblage sous le protecteur (*) vers la partie avant de la cabine, en fixant avec des brides au câble d'origine.

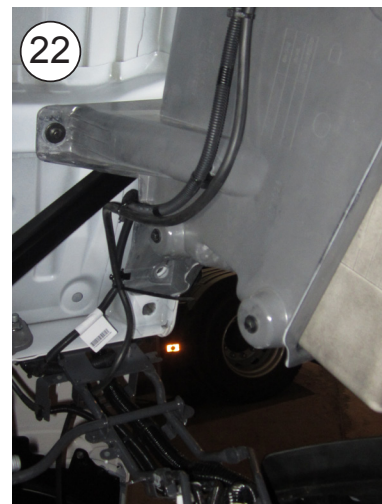
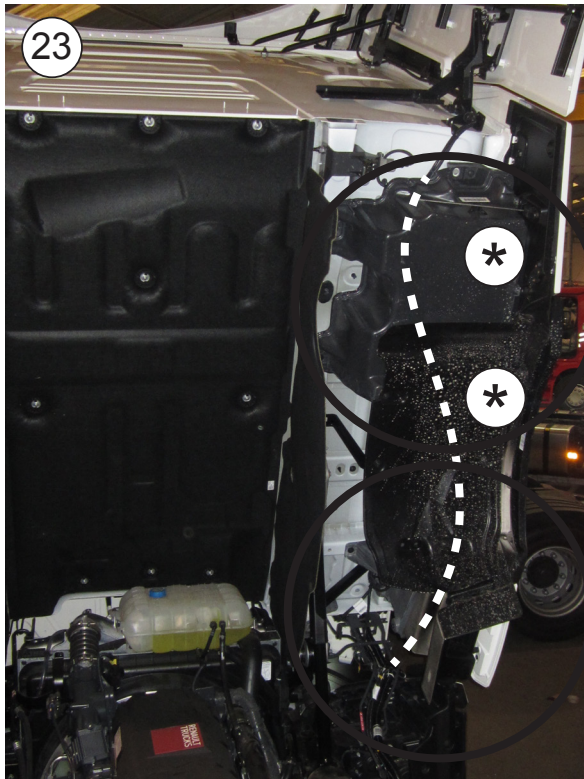

23

Laisser la cabine sur la position de marche et démonter les couvercles des connexions et le passage des câblages d'origine (*).

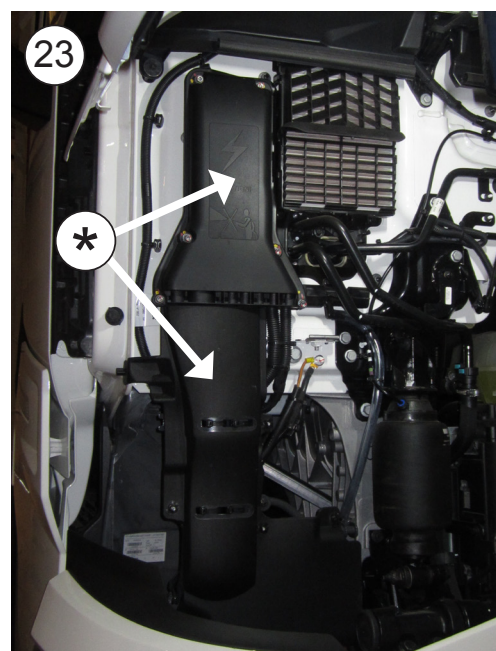

24 Connecter le câblage aux prises d'origine de (+) et (-), en le passant avec les câblages d'origine. Fixer le fusible avec une bride en plastique au câblage d'origine.

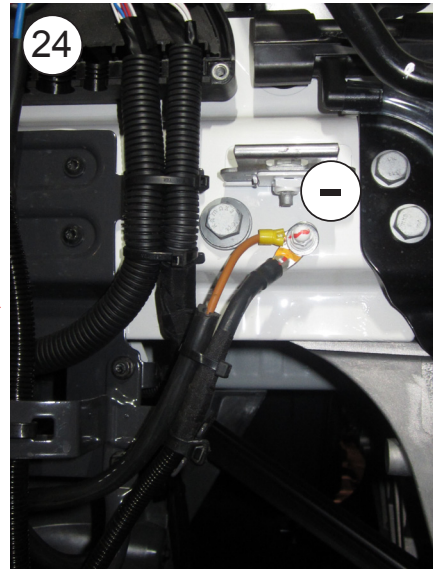
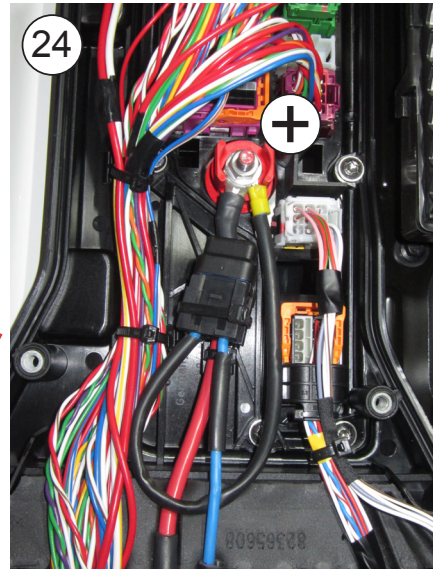
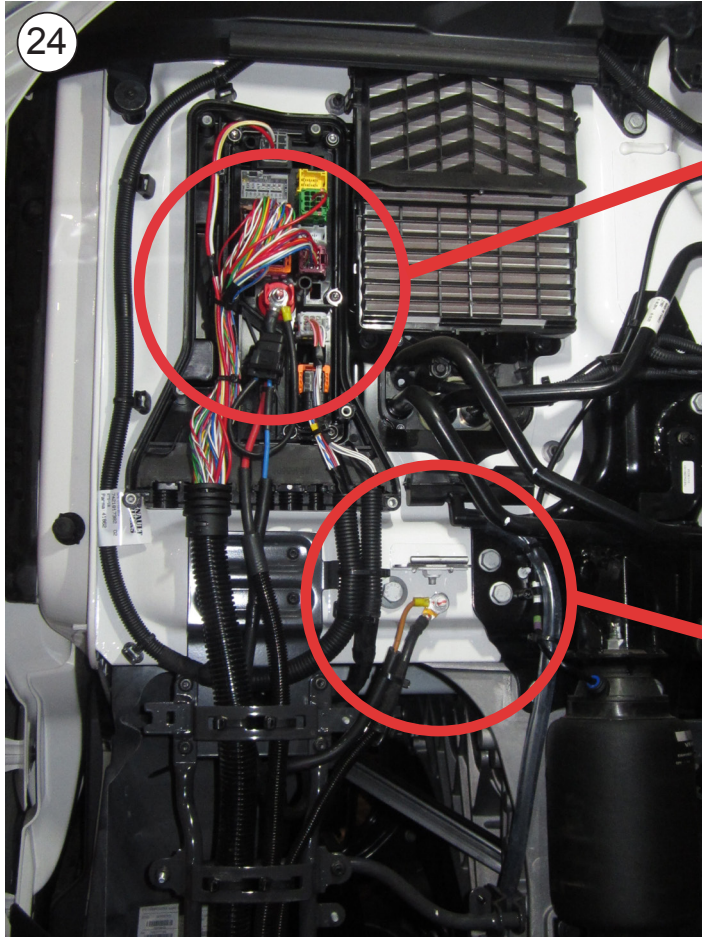

 **Attention ! Avant de mettre l'équipement en marche, il faut attendre au moins une heure après avoir placé la cabine en position de marche.**

Schéma électrique

AVIS IMPORTANT !

Attention de ne pas inverser les polarités au moment de connecter l'équipement. Si cela se produisait, la plaque de commande ne s'allumerait pas et l'équipement ne fonctionnerait pas.

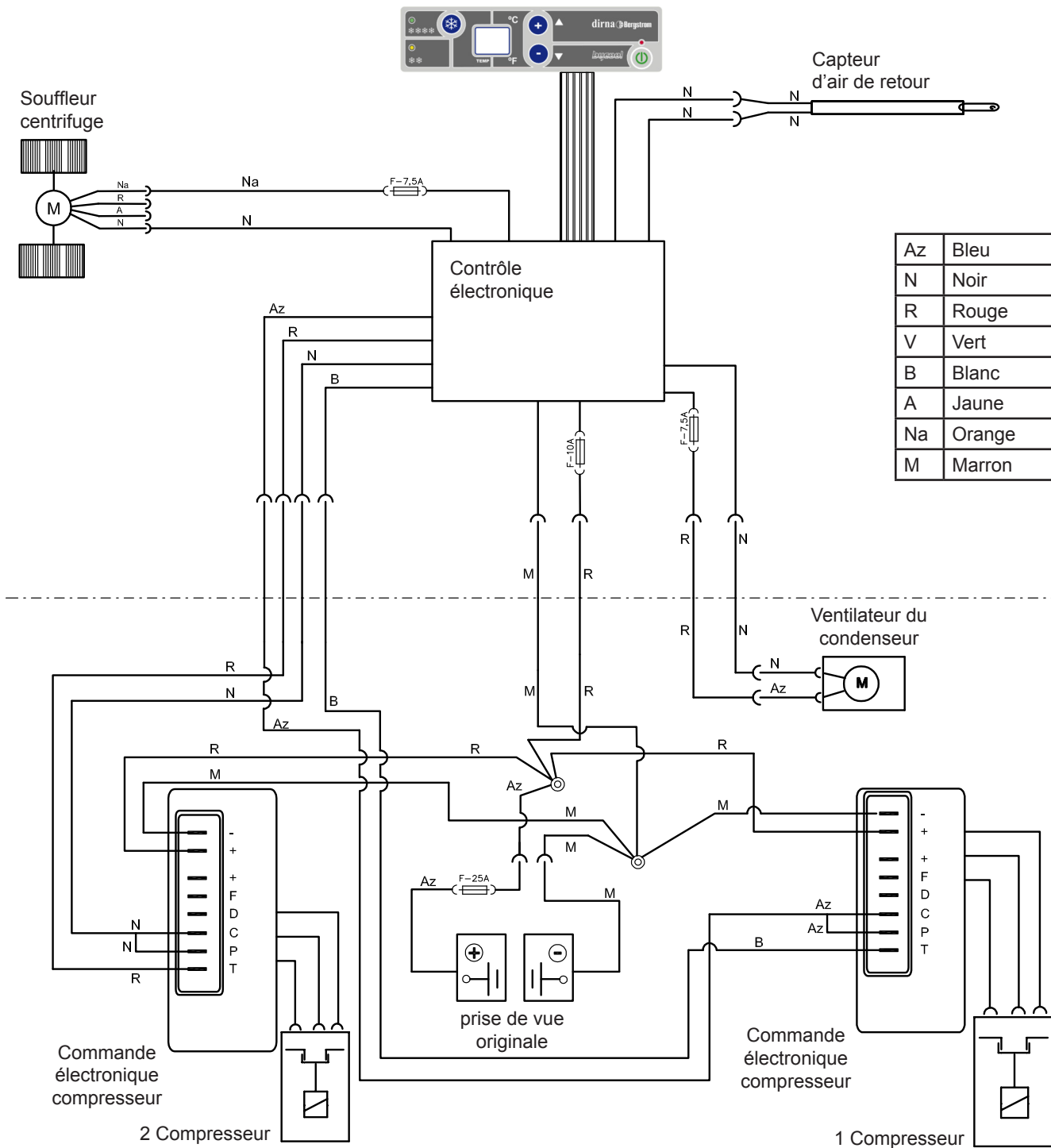

Empfehlungen Zur montage

- Vor und während der Montage bitte diese Anweisungen lesen und beachten.
- Benutzen Sie für jeden Arbeitsschritt die geeigneten Werkzeuge.

Elektrizität

- Zündschlüssel abziehen.
- Vor Montagebeginn die Batterie abklemmen.
- Den ordnungsgemäßen Anschluss und die korrekte Installation der Elektrokomponenten überprüfen.

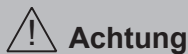

Achtung

Sollte sich das Gerät während der Montage neigen, muss man mindestens 60 Minuten warten, nachdem es wieder in die horizontale Lage gebracht wurde, um es wieder einzuschalten.

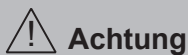

Achtung

Wird die Klimaanlage im Kabinendach installiert, muss der obere Teil der Kabine mit einem Tuch oder einer Decke gegen eventuelle Kratzer geschützt werden. Bei der Installation der **Compact** auf dem Kabinendach muss darauf geachtet werden, dass mit Luken ausgestattete Kabinen über eine ausreichend stabile Struktur verfügen, um das Gewicht des Geräts stand zu halten. Sollte das Fahrzeug über keine Luke verfügen und sollte es notwendig sein, das Kabinendach aufzuschneiden, bzw. sollte die vorhandene Struktur nicht ausreichend stabil sein (z.B. wenn sie aus Faser, Kunststoff usw. hergestellt ist), obliegt es dem Installateur zu entscheiden, ob das Kabinendach zur Vermeidung von Verformungen, Brüchen, undichten Stellen usw. verstärkt werden muss, und die hierfür notwendigen Mittel bereit zu stellen.

Werkzeuge

- Torx-Schraubenschlüssel
- Inbusschraubenschlüssel
- 10er, 13er, 14er Schraubenschlüssel
- Schere
- Metermaß

Mitgelieferte unterlagen

Montageanweisungen	1001261110
Ersatzteilliste	220RE00215

Symbolik



Fragile



Achtung Gericht!



Elektrische Gefährdung



Warnhinweise



Der Installateur muss im Bereich Fahrzeug-Klimaanlagen ausreichend geschult sein.



dirna Bergstrom, s.l. übernimmt keine Verantwortung für Schäden oder Brüche aufgrund einer nicht ordnungsgemäßen Installation oder Bedienung des Geräts oder den Austausch von Teilen bzw. Umbauten, die ohne die erforderliche schriftliche Genehmigung durchgeführt wurden.



Mit Kältemittel vorgefülltes Gerät R-134a. (Kältemittelkreislauf nicht manipulieren).



Siehe **Garantieverfahren** des Produkts in der **Fehlerdiagnose**.



Siehe **Benutzerleitfaden** des Geräts für den ordnungsgemäßen Betrieb der Fernbedienung und des Bedienfelds.



Die folgenden Unterlagen müssen dem Benutzer nach der Installation ausgehändigt werden: **Benutzerleitfaden**, **Garantie** und **Fehlerdiagnose**.

 Vor Montagebeginn vorderes Lufteintrittsgitter montieren.



1 Originalkonsole für den Zugriff auf die Befestigungsschrauben durch Ziehen am Ende der Lampen abnehmen.
Sind Leds (*) vorhanden, für die Demontage an diesen ziehen.



2 Luke durch Lösen der Befestigungsschrauben ausbauen (bei elektrischen Luken deren Klemme (*) abziehen).



3 Vor dem Aufkleben der EPDM-Dichtung Lukenbereich von eventuell vorhandenem Schmutz und Fett befreien. EPDM-Dichtung 30x25 um den herausstehenden Teil der Lukenausparung aufkleben.



4 **WIE DIE EPDM-DICHTUNG GESCHNITTEN WIRD, UM WASSERUNDICHTIGKEITEN IN DIE KABINE ZU VERMEIDEN**

A- Dichtung aufkleben und dabei einen Papierschutz von 100 mm auf jeder Seite beibehalten.

B- Die zwei Papierstücke entfernen.

C- Unter Anpressen beider Enden aufkleben.

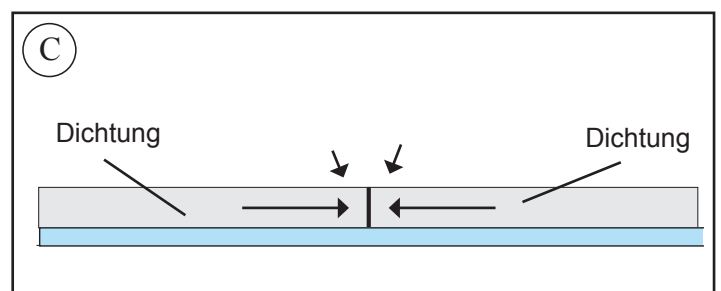
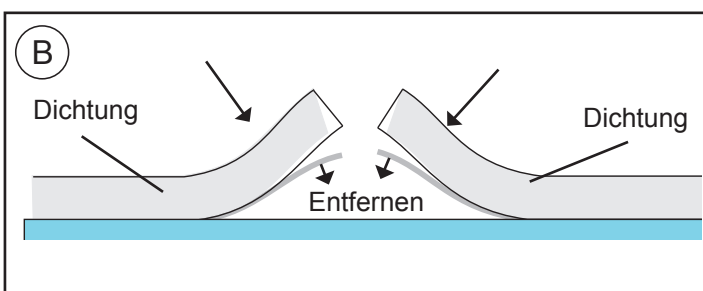
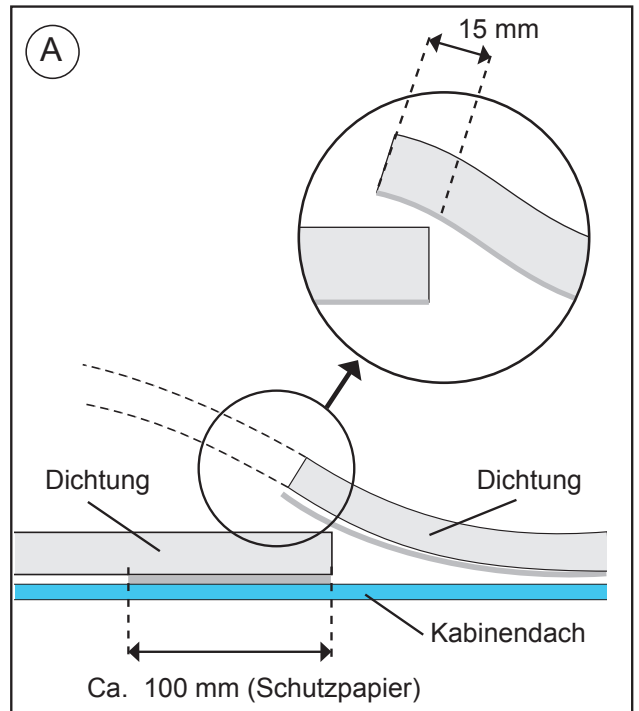

5 **Kabinenaussenseite: Compact** in der Lukenaussparung positionieren.
ACHTUNG: Beim Auflegen des Geräts auf die Lukenaussparung darauf achten, dass die Ablassausgänge nicht von der EPDM-Dichtung zusammengedrückt werden.

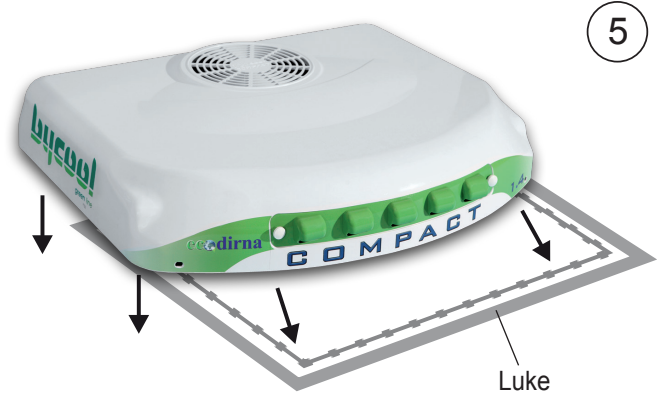

6 Verbindungsstück der Schaumgummidurchführung anbringen, wobei der weichere Teil auf der Gerätegrundplatte aufliegt.



7 Unterlegscheiben wie angegeben auf die Distanzstücke stecken.

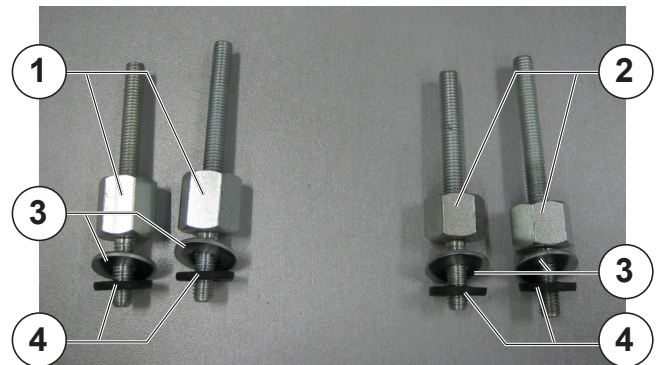

- 1.- Distanzstück 22 mm
- 2.- Distanzstück 17 mm
- 3.- Breitflansch-Flachscheibe Ø 8
- 4.- Gummischeibe Ø 20 x Ø 7 x 3 mm

8 Unterlegscheiben wie angegeben auf die Distanzstücke stecken.

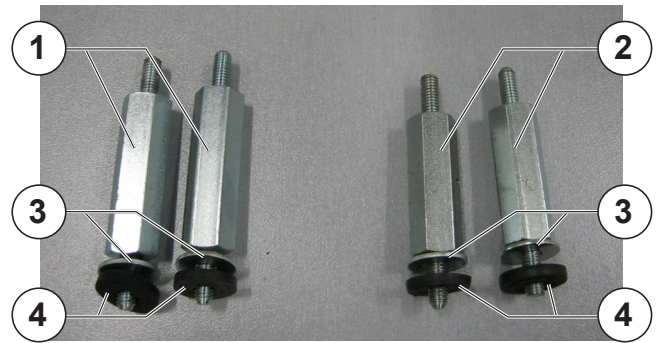

- 1.- Distanzstück 50 mm
- 2.- Distanzstück 43 mm
- 3.- Breitflansch-Flachscheibe Ø 8
- 4.- Gummischeibe Ø 18 x Ø 6 x 3 mm

9 Distanzstücke unter Beachtung der Position entsprechend ihrer Maße anbringen und anziehen.



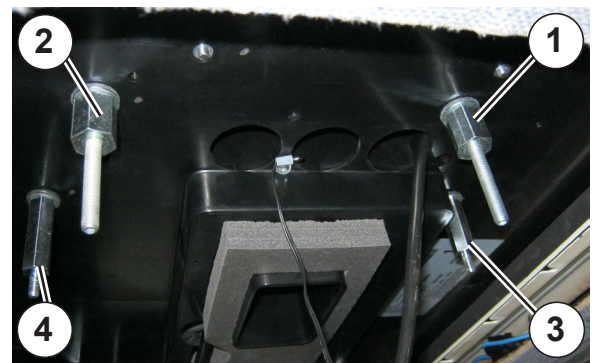

- 1.- Distanzstück M8 22 mm
- 2.- Distanzstück M8 17 mm
- 3.- Distanzstück M6 50 mm
- 4.- Distanzstück M6 43 mm

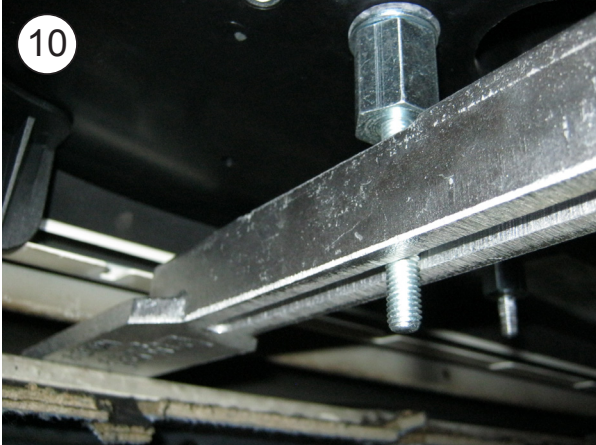

- 1.- Distanzstück M8 22 mm
- 2.- Distanzstück M8 17 mm
- 3.- Distanzstück M6 50 mm
- 4.- Distanzstück M6 43 mm

10 Halterungen unter der Verkleidung auf Stiftschrauben M8 stecken. (4) Breitflansch-Flachscheiben Ø8 und (4) selbstsichernde Muttern M8 einsetzen, ohne sie komplett festzuziehen.



 **Vorsicht:** Darauf achten, dass die Lukenkabel nicht eingeklemmt werden.



11

Den 2-Wege-Kasten des Abluftensors, den 4-Wege-Kasten des Gebläses und den 8-Wege-Kasten der Kabel der Elektroniksteuerung anschließen.

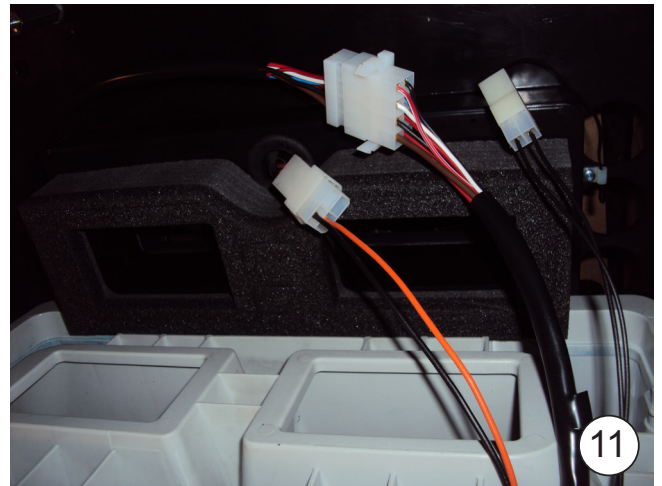

12

Innere Luftverteiltertafel mit (4) Sechskant-Verbindungs-muttern unter Beachtung der Position entsprechend der Maße montieren.

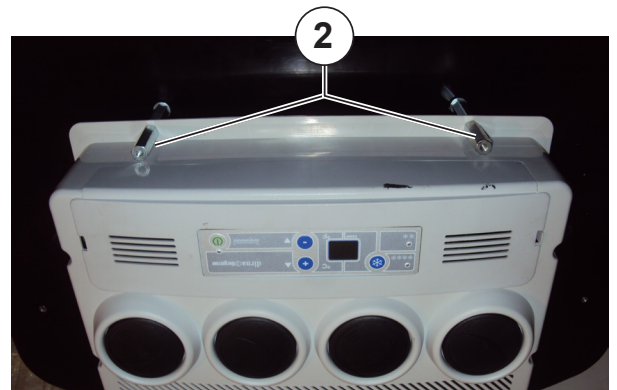
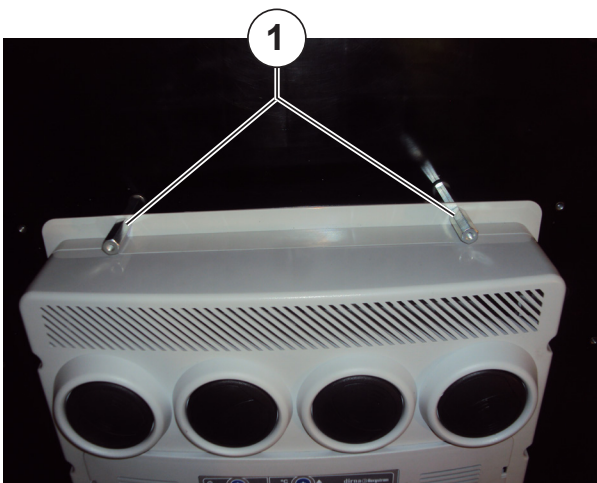

- 1.- Distanzstück 50 mm vornea
- 2.- Distanzstück 43 mm hinten

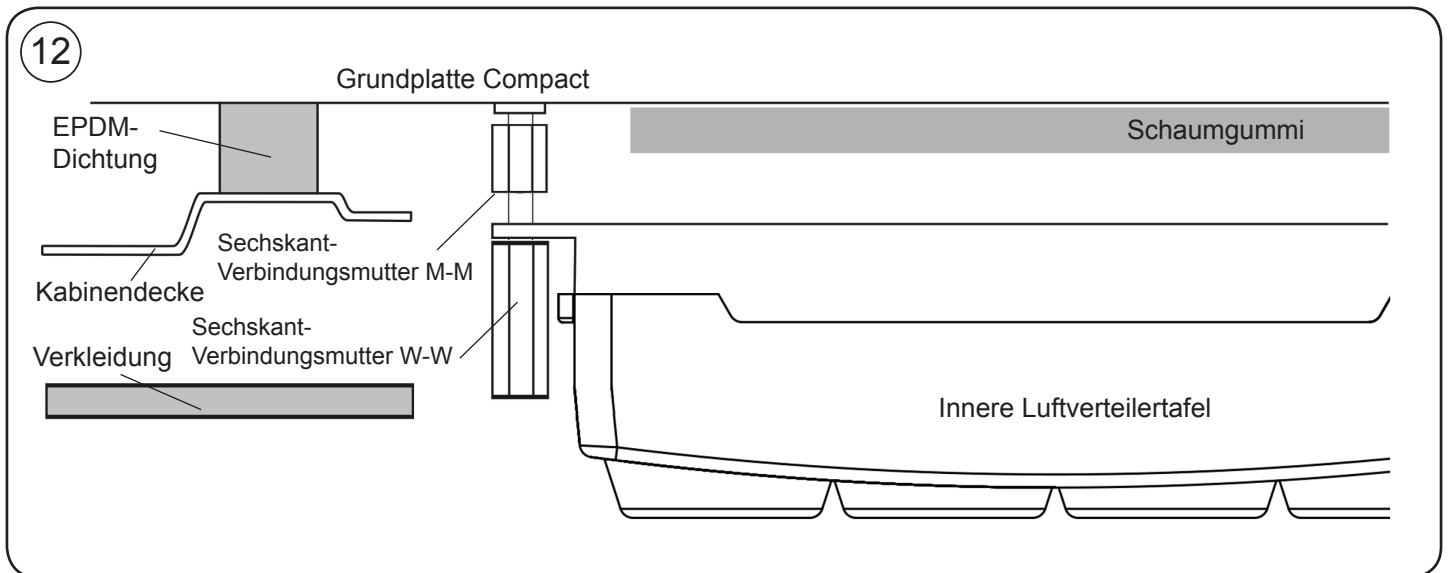

13 Konsole unter Markierung von (4) Schrauben M6x16 auflegen und Gerät zentrieren, bis sie sich an derjenigen Position der Verkleidung befindet, wo die Originalkonsole montiert war.



14 Nach dem Zentrieren Konsole abnehmen und die Halterungen anziehen, bis sie an die Sechskant-Verbindungs-muttern anschlagen.



15

Von Außen prüfen, ob die Entwässerungsleitungen der Anlage frei sind und nicht mit der EPDM-Dichtung in Konflikt kommen.

16

Konsole erneut mit Schrauben M6x16 montieren und diese anziehen, bis sie an die Sechskant-Verbindungs-muttern anschlagen.



17

Lichter anschließen und durch Drücken auf die Konsole einrasten lassen.



EXPLOSIONSANSICHT BIS ZUR BEFESTIGUNG DER HALTERUNGEN

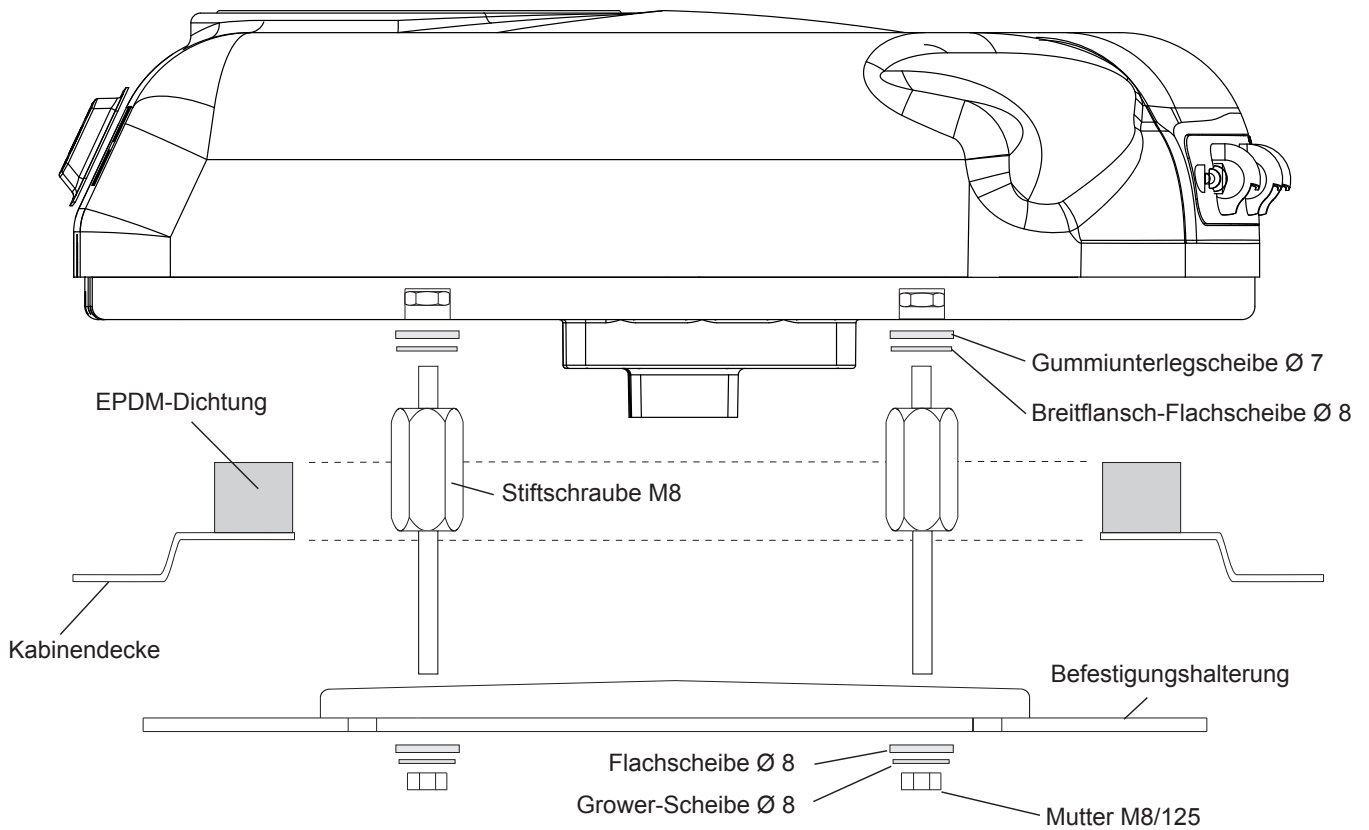

EXPLOSIONSANSICHT BIS ZUR BEFESTIGUNG DER KONSOLE

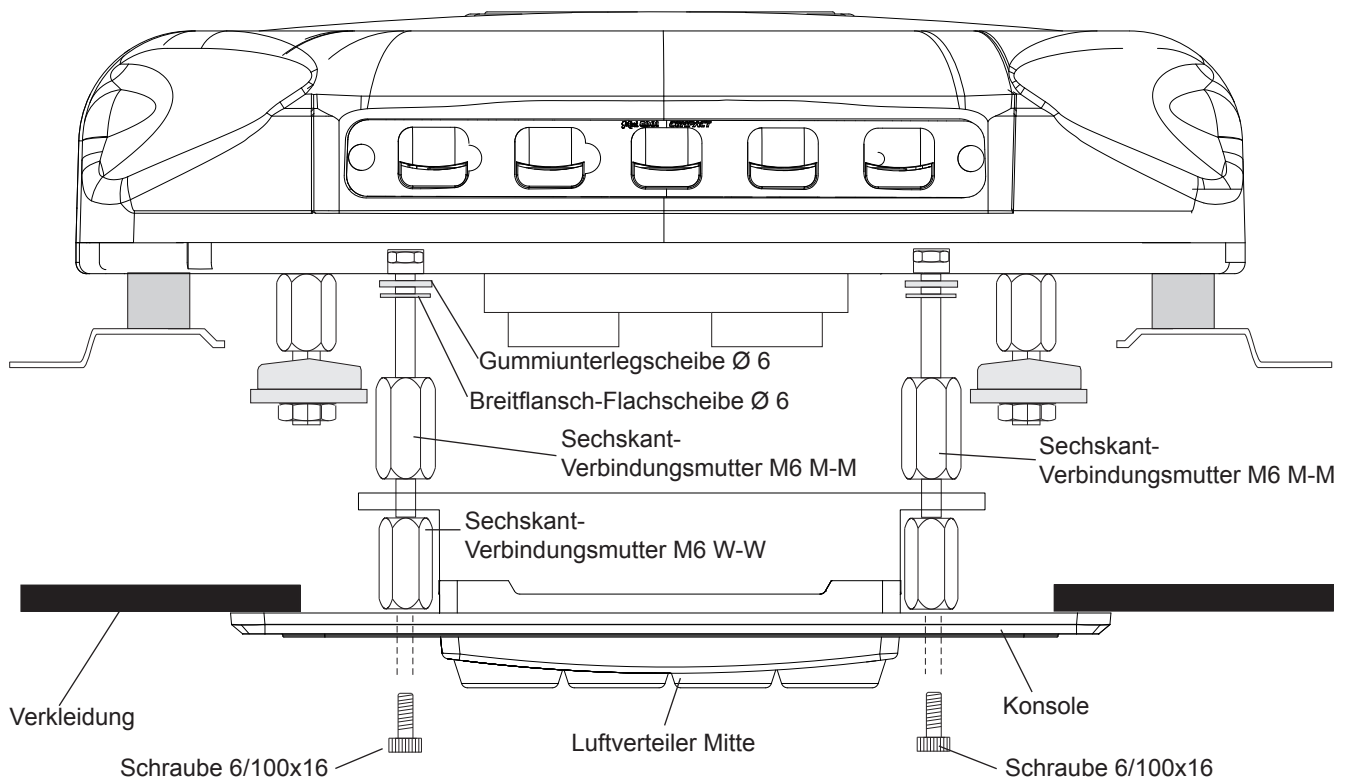

18 Netzkabel unter dem Spoiler durchführen und am Gerät anschließen. Anschlussklemmen am Dach mit Kabelhaltern und Kleber sowie Kunststoff-Kabelbindern befestigen.

Achtung: Den Bereich vor dem Aufkleben der Halter sorgfältig reinigen.

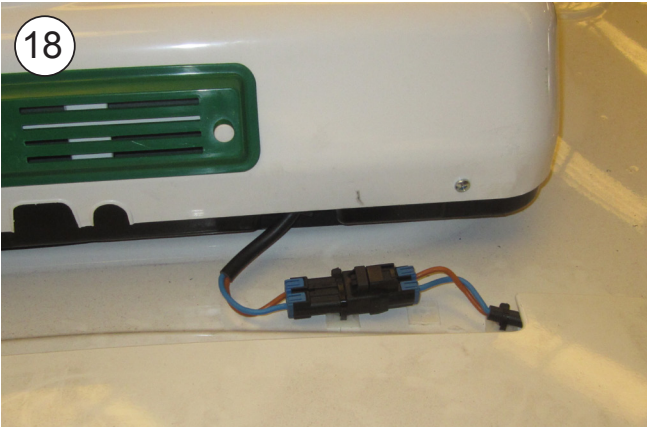
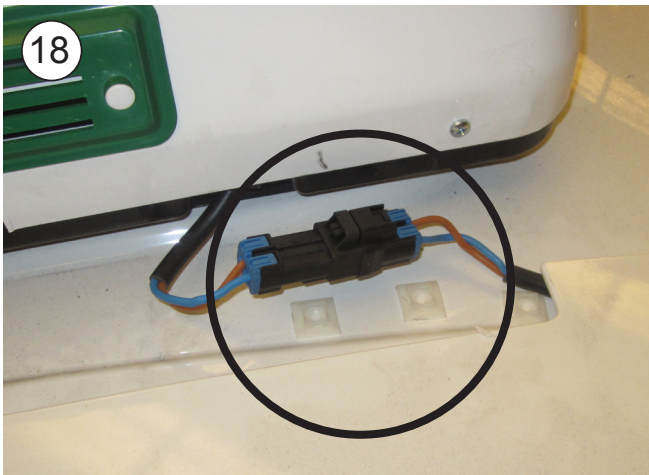

19 Spoilerhalterungen rechts lockern und Kabel direkt an der Kabinenecke darunter hindurchführen. Spoilerhalterungen wieder in die Originalposition bringen.



20 Kabel unter dem Spoiler mit Klebehaltern und Kabelbindern befestigen.

Achtung: Den Bereich vor dem Aufkleben der Halter sorgfältig reinigen.



21 Kabel mit Klebehaltern und Kabelbindern an Kabine, seitlichem Spoilerhalter und Originalkabel befestigen.

Achtung: Den Bereich vor dem Aufkleben der Halter sorgfältig reinigen.

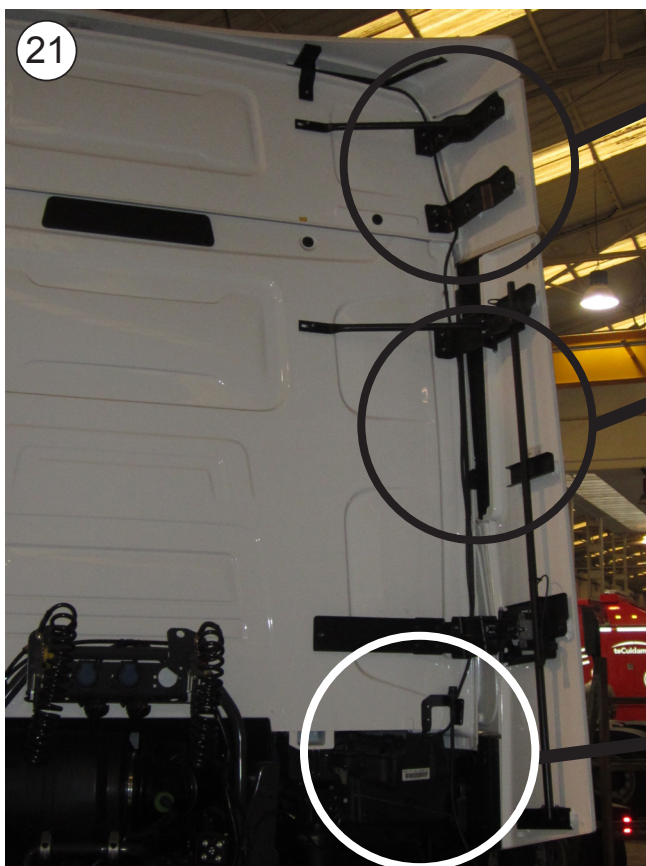
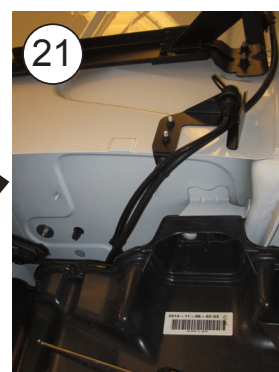

22 Kabine abklappen und Kabel unter der Schutzvorrichtung (*) bis zum vorderen Teil der Kabine hindurchführen. Mit Kabelbindern an den Originalkabeln befestigen.

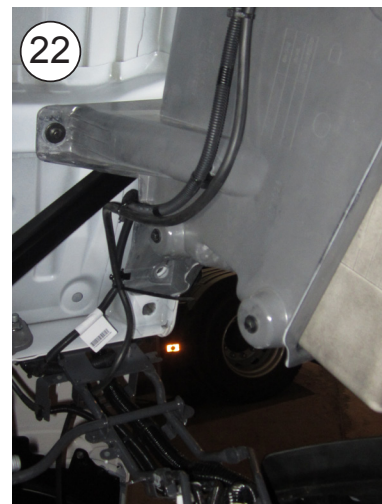
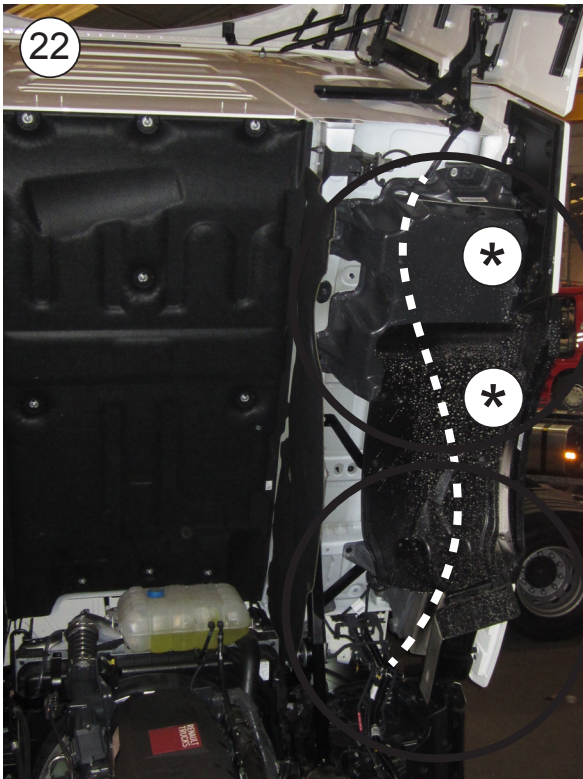

23 Kabine in Fahrposition bringen und Abdeckungen der Anschlusskästen sowie Original-Kabelführungen abnehmen (*).

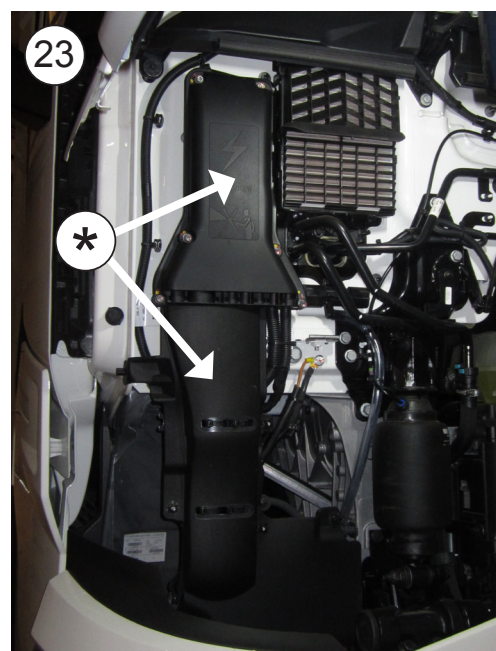

24 Kabel an Originalanschlüsse (+) und (-) anschließen und zusammen mit den Originalkabeln durchführen. Sicherung mit Kunststoff-Kabelbinder an der Originalverkabelung befestigen.

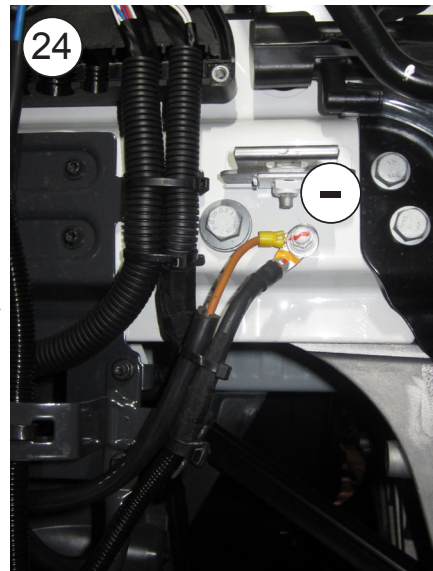
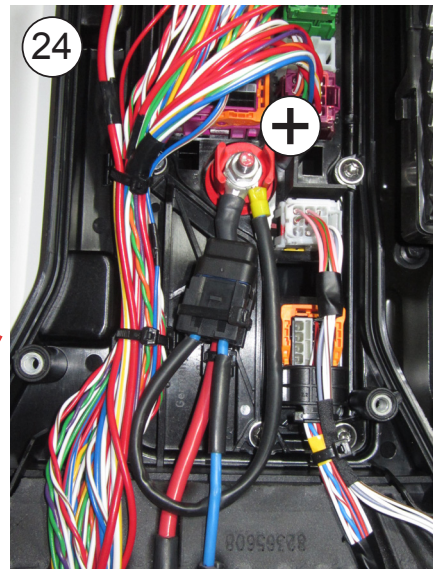
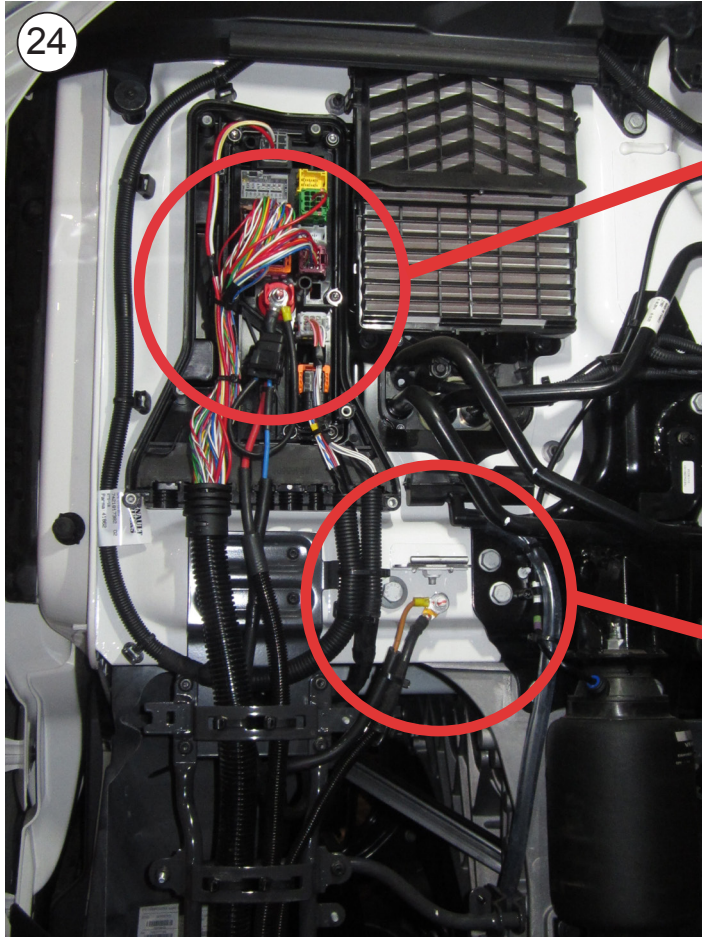

 **Achtung!** Vor der Inbetriebnahme des Geräts mindestens eine Stunde warten, nachdem die Kabine in Fahrposition gebracht worden ist.

WICHTIGER HINWEIS!

Darauf achten, dass die Polaritäten beim Anschluss des Geräts nicht vertauscht werden. Ist dies der Fall, schaltet sich das Bedienfeld nicht ein und das Gerät funktioniert nicht.

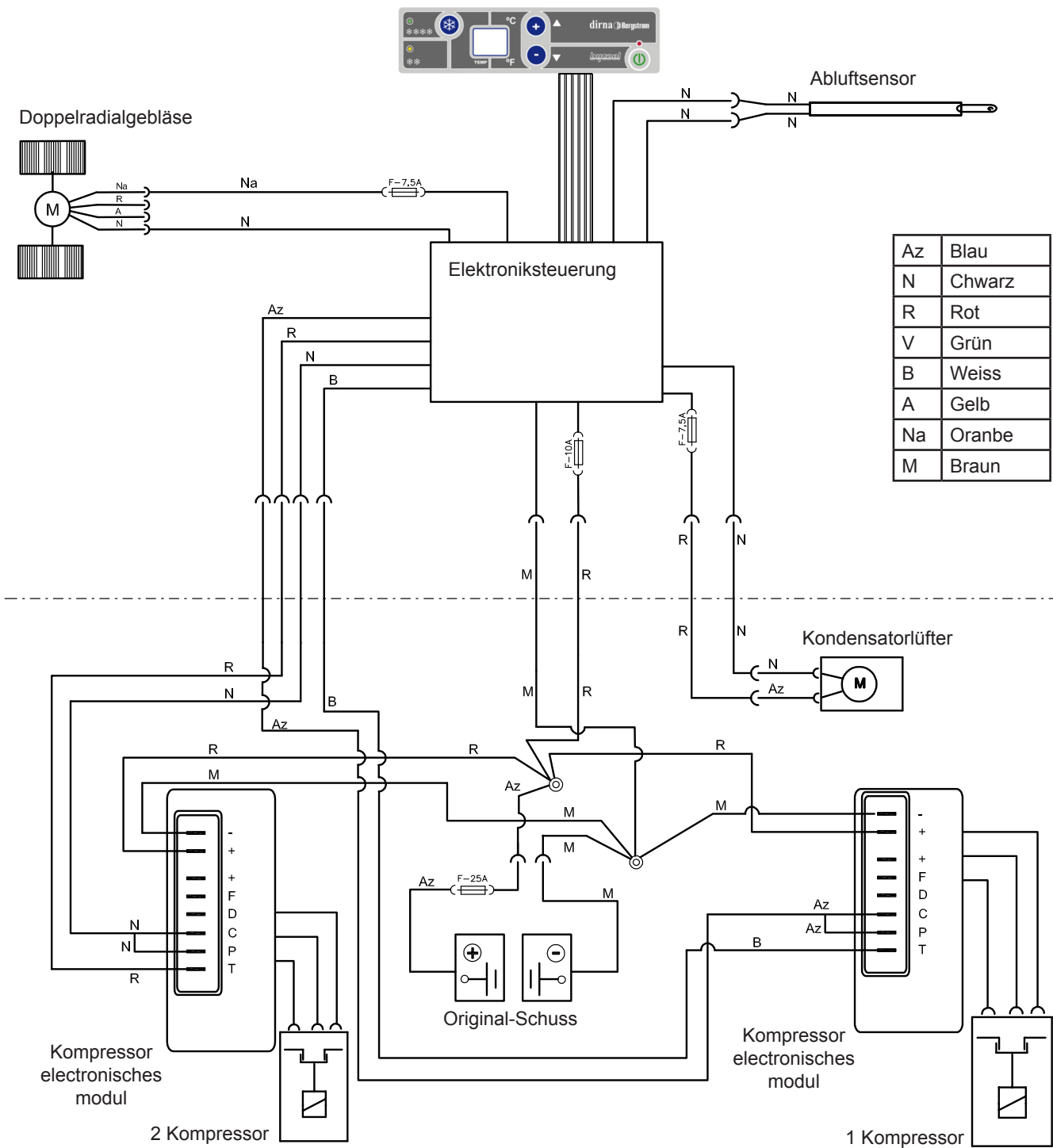

Suggerimenti per il montaggio

- Prima di cominciare il montaggio, leggere attentamente le istruzioni e rispettarle nel corso dello stesso.
- Usare gli attrezzi più adatti ad ogni operazione.

Elettricità

- Scollegare la chiave di contatto.
- Scollegare la batteria prima di cominciare il montaggio.
- Assicurarsi di avere effettuato correttamente l'installazione e il collegamento dei componenti elettrici.

Attenzione

Se durante il montaggio si inclina l'impianto, prima di rimetterlo in funzione occorre attendere almeno 60 minuti dal momento in cui è di nuovo in posizione orizzontale.

Attenzione

Quando si installa l'impianto di aria condizionata sul tettuccio, bisogna proteggere la parte superiore della cabina con uno straccio o una coperta per evitare eventuali graffi. Per l'installazione del **Compact**, tenere presente che normalmente le cabine munite di oblò dispongono di una struttura abbastanza solida per sostenere il peso dell'impianto. Tuttavia, se così non fosse e se fosse necessario tagliare il tettuccio, o se in presenza di oblò la struttura non fosse abbastanza rigida (se fosse di fibra, plastica, ecc.), è responsabilità dell'installatore decidere se occorre rinforzare il tettuccio per evitare qualsiasi deformazione, rottura o penetrazione d'acqua, ecc., prendendo le misure necessarie per evitarlo.

Attrezzi

Kit di chiavi Torx
 Kit di chiavi Allen
 Chiave fissa 10, 13, 14
 Forbici
 Metro a nastro

Documentazione allegata

Istruzioni di montaggio	1001261110
Elenco ricambi	220RE00215

Simbologia



Fragile



Attenzione alle mani



Tensione elettrica pericolosa

Avvertenze



L'installatore deve essere in possesso della formazione necessaria in materia di aria condizionata per veicoli.



dirna Bergstrom, s.l. declina ogni responsabilità per danni o rotture derivanti dall'errata installazione o dall'errato uso dell'impianto o da sostituzioni o modifiche effettuate senza la necessaria autorizzazione per iscritto.



Impianto precaricato con gas refrigerante R-134. (Non manomettere il circuito di gas refrigerante).



Vedi la **procedura di garanzia** del prodotto in **Diagnosi dei problemi**.



Vedi la **Guida dell'utente** dell'impianto per il corretto funzionamento del telecomando e del pannello di controllo.



I seguenti documenti devono essere consegnati all'utente una volta conclusa l'installazione: **Guida dell'utente, Garanzia e Diagnosi dei problemi**.



Prima di cominciare il montaggio, montare la griglia anteriore d'entrata dell'aria.



1

Smontare la console originale, tirando l'estremità delle luci per accedere alle viti di fissaggio.

In presenza di led (*) smontare tirando questi ultimi.



2

Smontare il tettuccio apribile svitando le viti di fissaggio (in caso di tettuccio elettrico, disinserire il relativo morsetto [*]).



3

Prima di incollare la guarnizione EPDM, pulire l'area del tettuccio apribile da eventuali tracce di sporco e di grasso. Incollare la guarnizione EPDM 30x25 lungo la sporgenza perimetrale del vano del tettuccio apribile.



4

COME TAGLIARE LA GUARNIZIONE EPDM PER EVITARE INFILTRAZIONI NELLA CABINA

A- Incollare la guarnizione mantenendo una protezione di carta di 100 mm su ogni lato.

B- Rimuovere i due pezzi di carta.

C- Incollare premendo su entrambe le estremità.

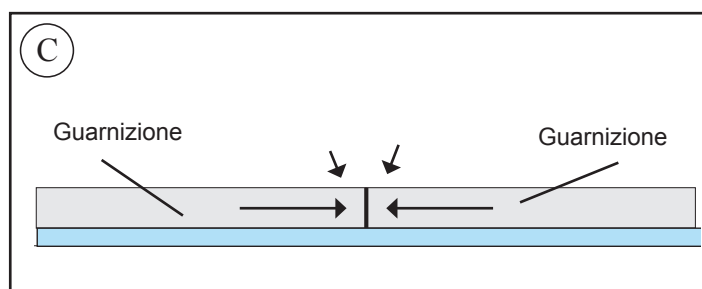
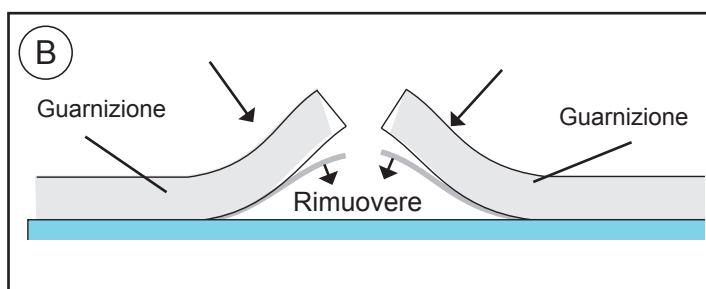
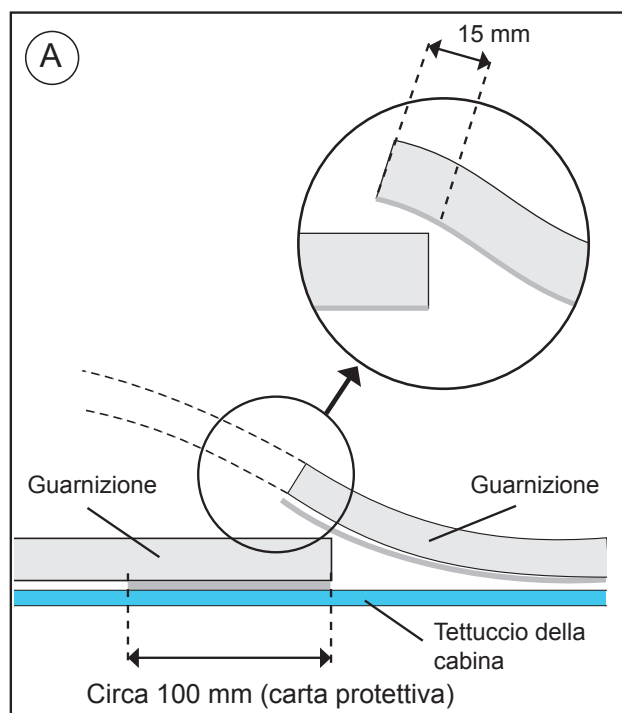

5 **Esterno cabina:** inserire l'impianto nel vano del tettuccio apribile.

Attenzione: mentre si sistema l'impianto nel vano del tettuccio apribile, controllare che le uscite di scarico non siano tappate dalla guarnizione EPDM.

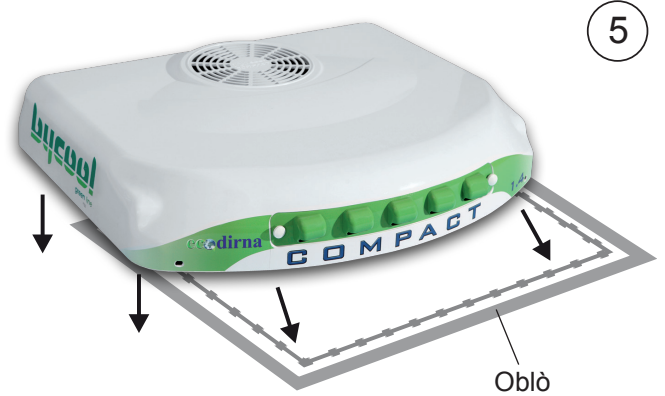

6 Posizionare le sedi del canalizzatore con la parte più morbida sulla base dell'impianto.



7 Montare le rondelle sui distanziatori procedendo come indicato.

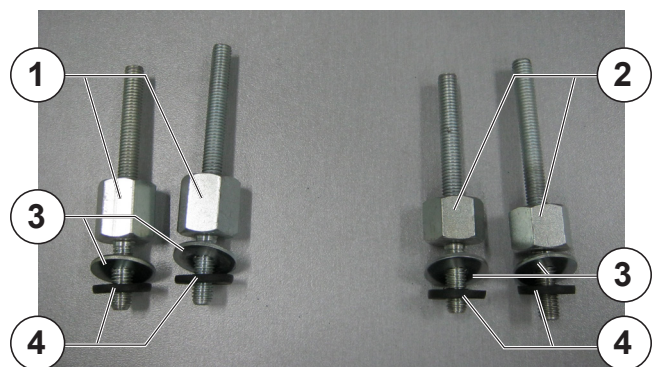

- 1.- Distanziatore 22 mm
- 2.- Distanziatore 17 mm
- 3.- Rondella piana Ø 8 a testa larga
- 4.- Rondella gomma Ø 20 x Ø 7 x 3 mm

8

Montare le rondelle sui distanziatori procedendo come indicato.

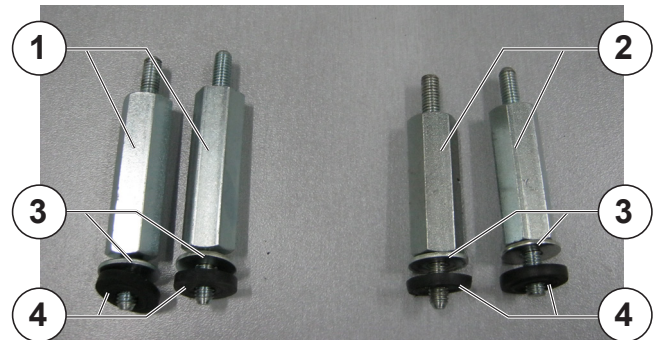

- 1.- Separador 50 mm
- 2.- Separador 43 mm
- 3.- Arandela plana Ø 8 ala ancha
- 4.- Arandela goma Ø 18 x Ø 6 x 3 mm

9

Montare e stringere i distanziatori tenendo conto della posizione a seconda delle relative dimensioni.



- 1.- Distanziatore M8 22 mm
- 2.- Distanziatore M8 17 mm
- 3.- Distanziatore M6 50 mm
- 4.- Distanziatore M6 43 mm

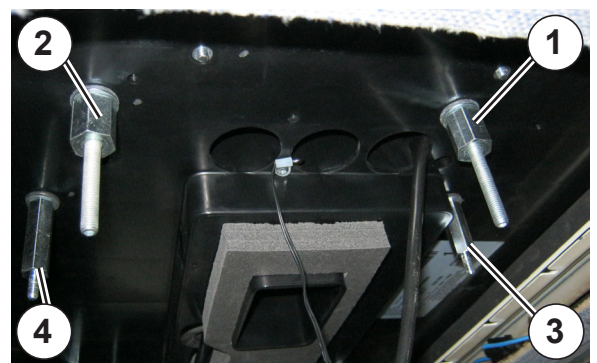

- 1.- Distanziatore M8 22 mm
- 2.- Distanziatore M8 17 mm
- 3.- Distanziatore M6 50 mm
- 4.- Distanziatore M6 43 mm

- 10** Inserire i supporti sulle viti prigioniere M8 sotto la tappezzeria. Inserire (4) rondelle piane Ø 8 a testa larga e (4) dadi M8 autobloccanti senza stringere del tutto.

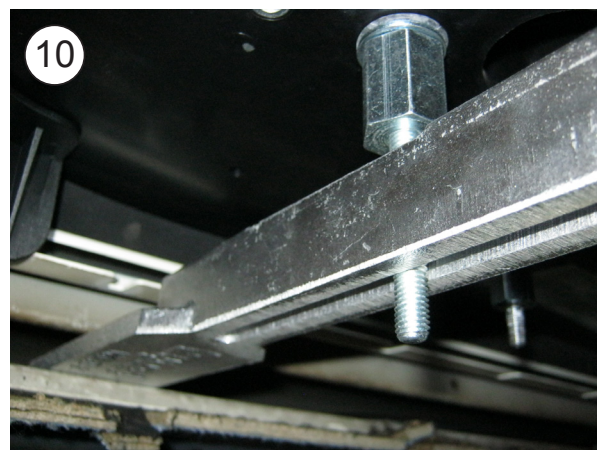

Attenzione: Fare attenzione a non strozzare il cablaggio del tettuccio apribile.



11

Collegare la scatola a 2 vie del sensore dell'aria di ritorno, la scatola a 4 vie del ventilatore e quella a 8 vie di connessione dei cablaggi del controllo elettronico.

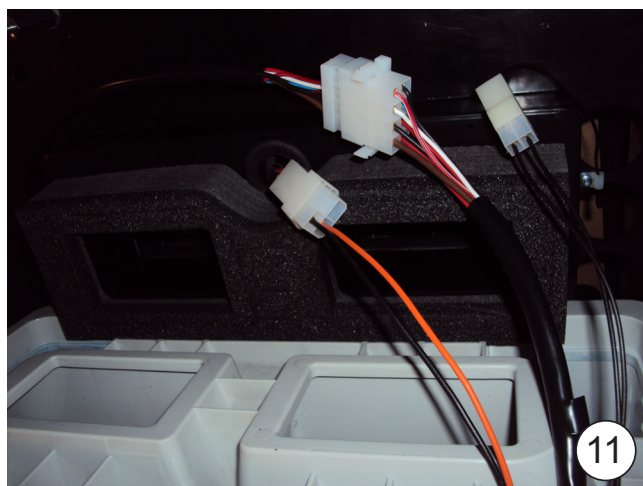

11

12

Montare il pannello interno di distribuzione dell'aria con (4) perni esagonali, tenendo conto della posizione a seconda delle dimensioni.

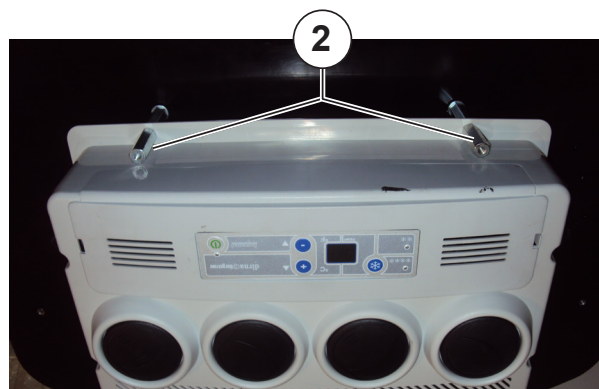
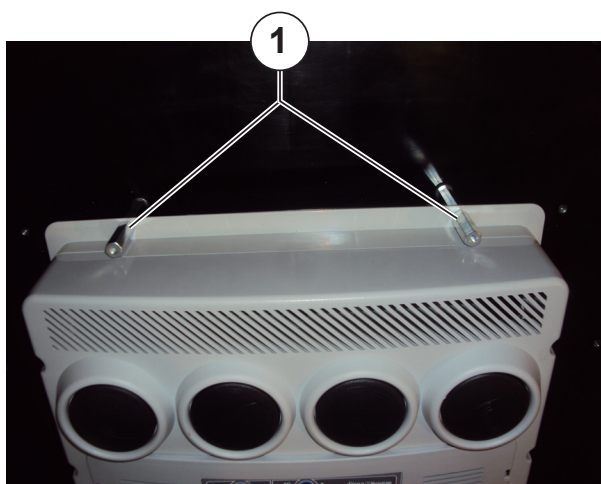

- 1.- Distanziatore 50 mm in parte anteriore
- 2.- Distanziatore 43 mm parte posteriore

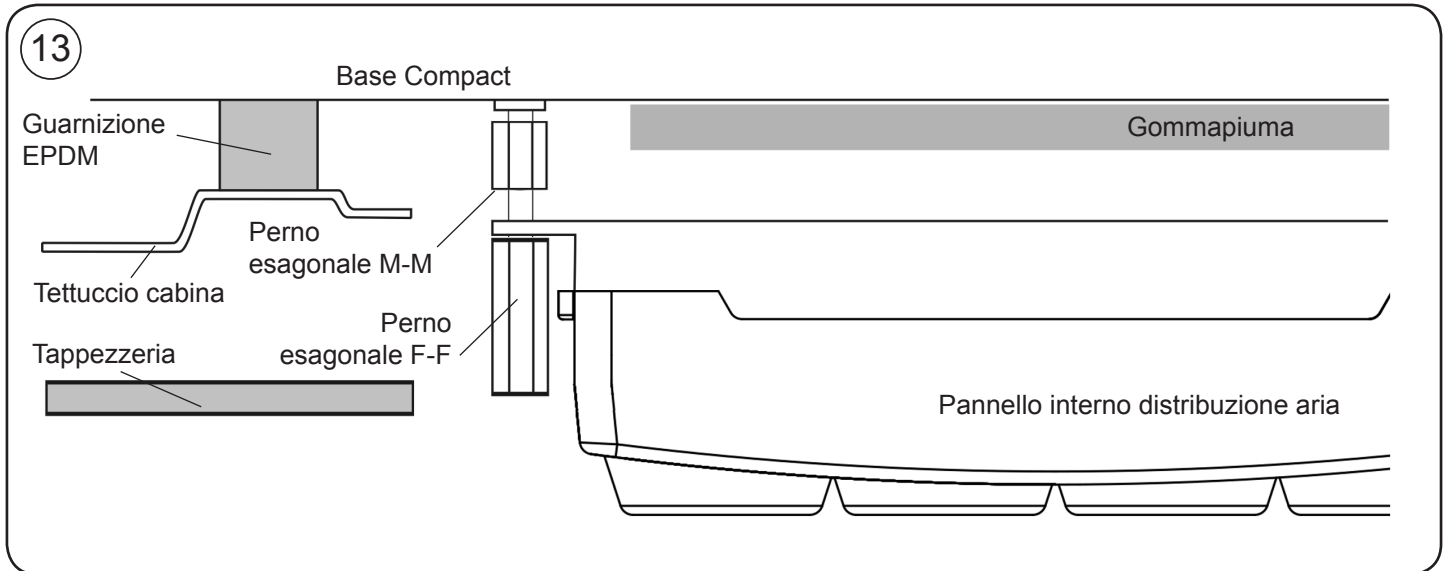

13 Montare la console inserendo (4) viti M6x16 e centrare l'impianto fino a fare coincidere la console con la posizione della tappezzeria in cui era montata quella originale.



14 Una volta centrato l'impianto, smontare la console e stringere i supporti fino a battuta con i perni esagonali.

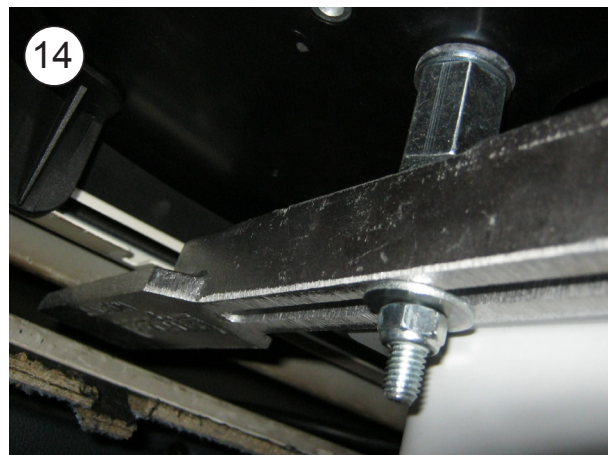

15

Verificare dall'esterno che gli scarichi dell'impianto siano liberi e che non interferiscano con la guarnizione EPDM dell'impianto.

16

Rimontare la console con le viti M6x16 stringendo fino a battuta con i perni esagonali.



17

Collegare le luci e incastrarle esercitando pressione sulla console.



ESPLOSO FINO AL FISSAGGIO DEI SUPPORTI DI FISSAGGIO

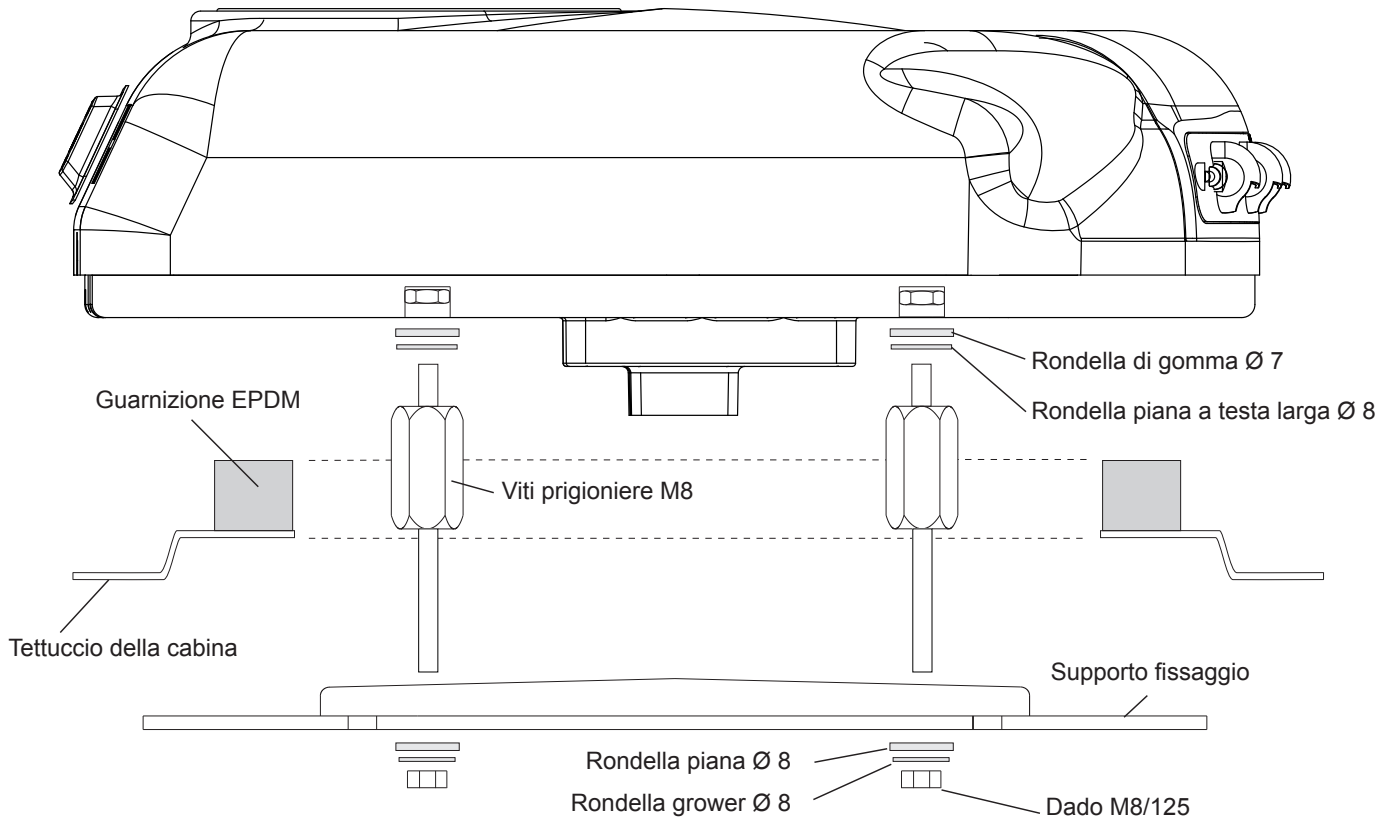

ESPLOSO FINO AL FISSAGGIO DELLA CONSOLLE

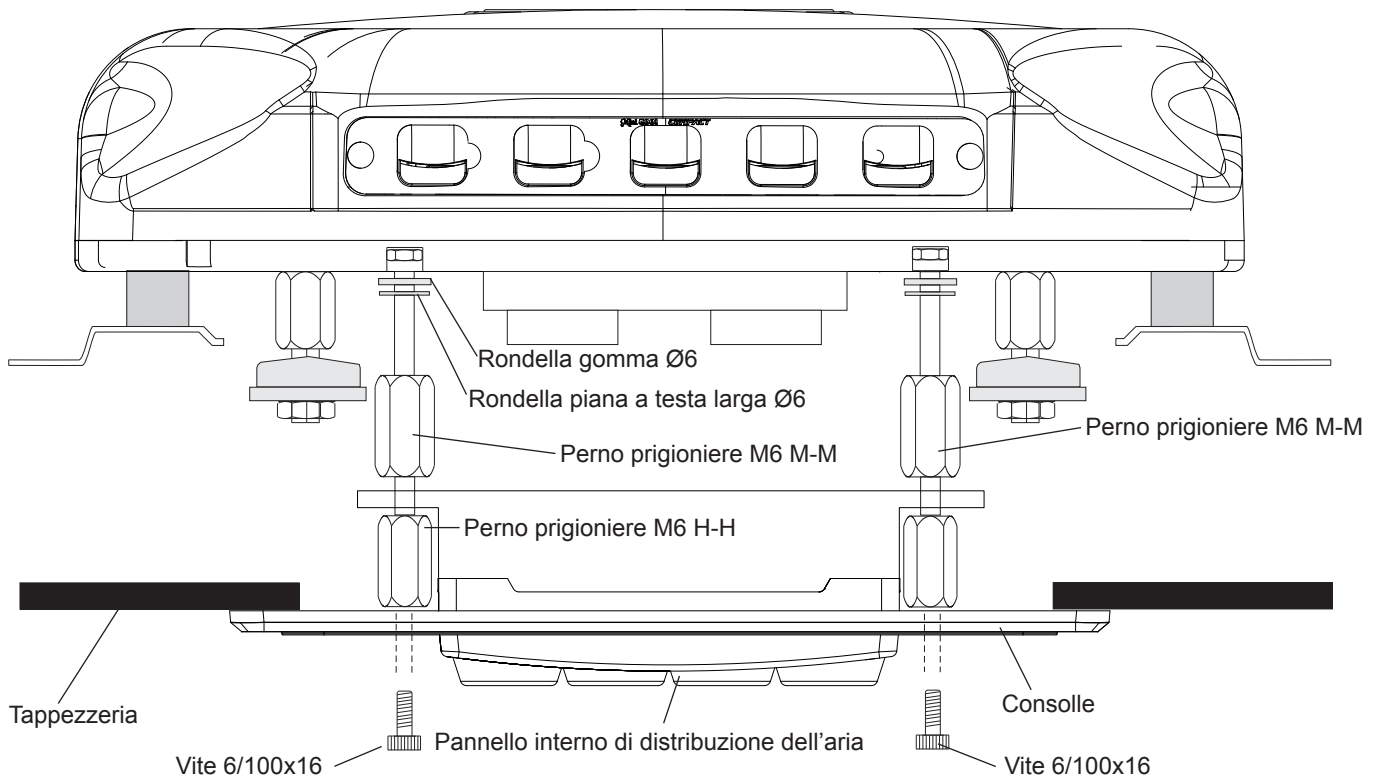

- 18** Far passare il cablaggio di alimentazione sotto lo spoiler e collegarlo all'impianto, fissare i morsetti di connessione al tettuccio con i supporti adesivi e le fascette di plastica.

Attenzione: pulire bene la zona prima di incollare i supporti adesivi.

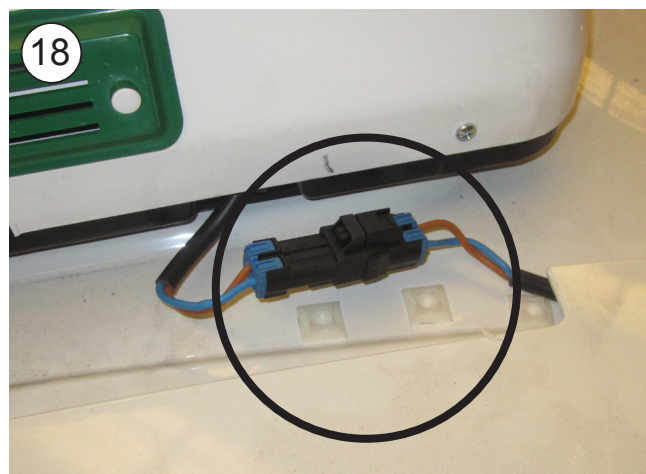
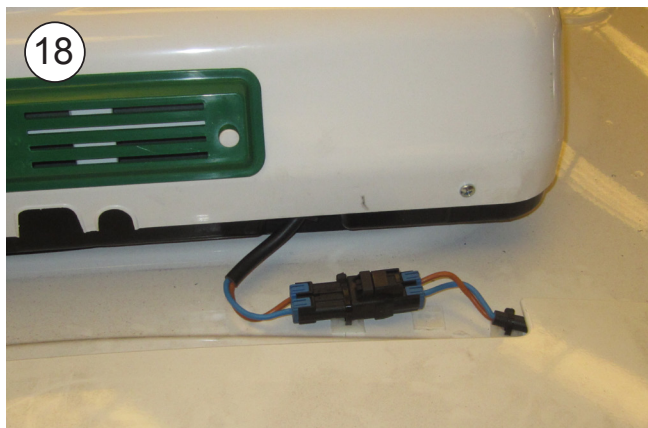

- 19** Allentare i supporti dello spoiler, sul lato destro, e far passare il cablaggio al di sotto degli stessi, sullo spigolo della cabina e rimettere a posto i supporti dello spoiler.



20 Fissare il cablaggio sotto lo spoiler con i supporti adesivi e le fascette di plastica.

Attenzione: pulire bene la zona prima di incollare i supporti adesivi.



21 Fissare il cablaggio con i supporti adesivi e le fascette alla cabina, al supporto dello spoiler laterale e al cablaggio originale.

Attenzione: pulire bene la zona prima di incollare i supporti adesivi.

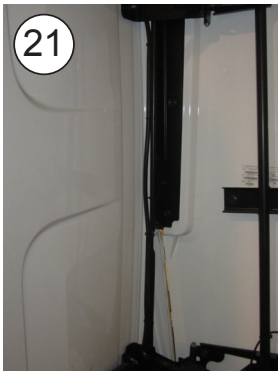

22

Ribaltare la cabina e far passare il cablaggio al di sotto della protezione (*) verso la parte anteriore della cabina, fissandolo con le fascette al cavo originale.

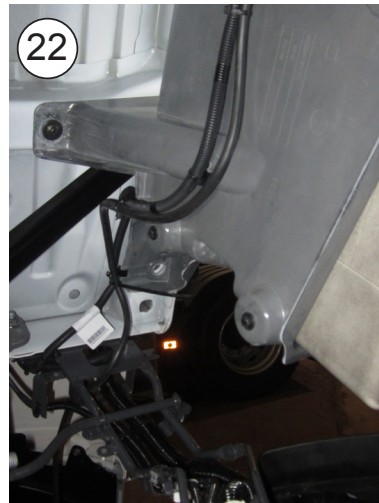
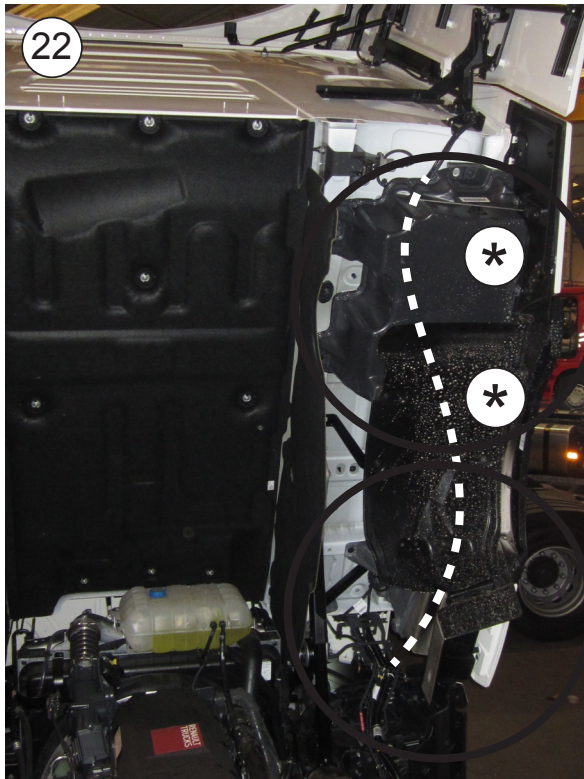

23

Mettere la cabina in posizione di marcia e smontare i coperchi delle connessioni e il passaggio dei cablaggi originali (*).

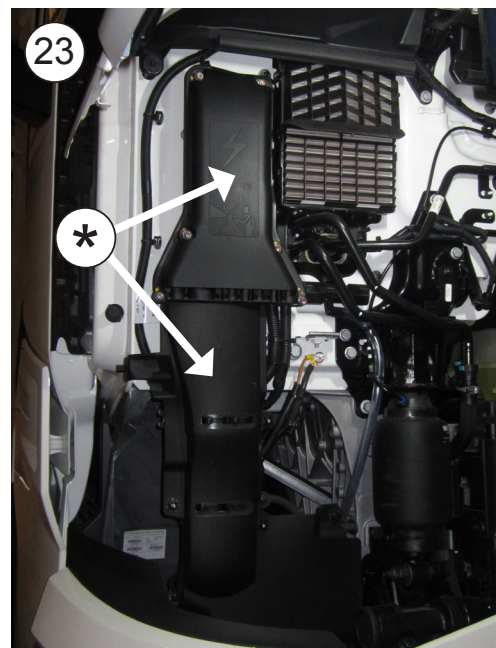

24

Collegare il cablaggio alle prese originali (+) e (-) facendolo passare con i cablaggi originali. Fissare il fusibile con una fascetta di plastica al cablaggio originale.

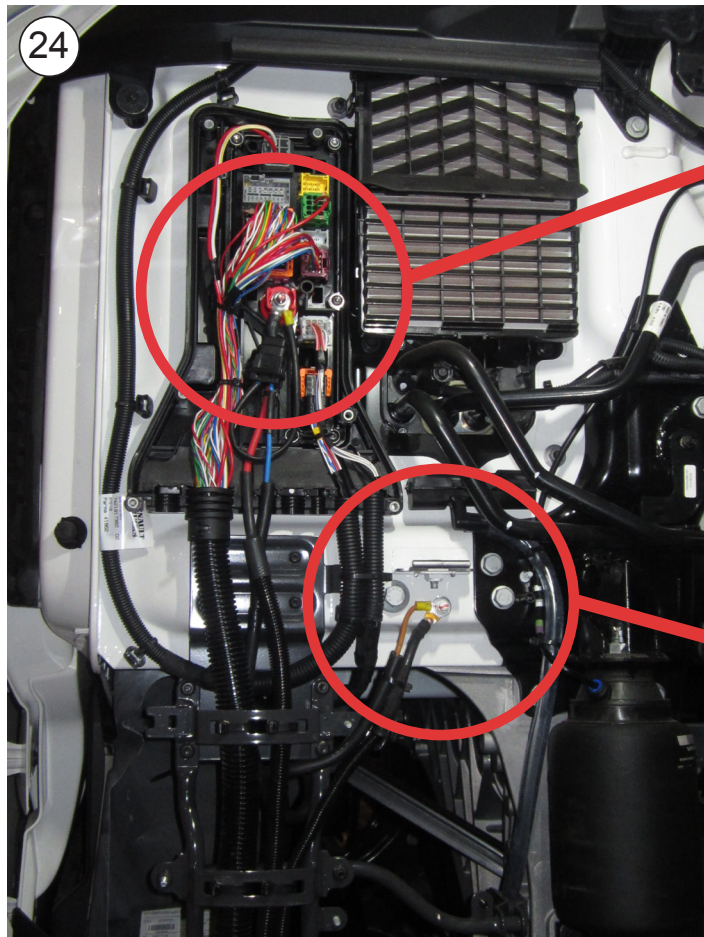
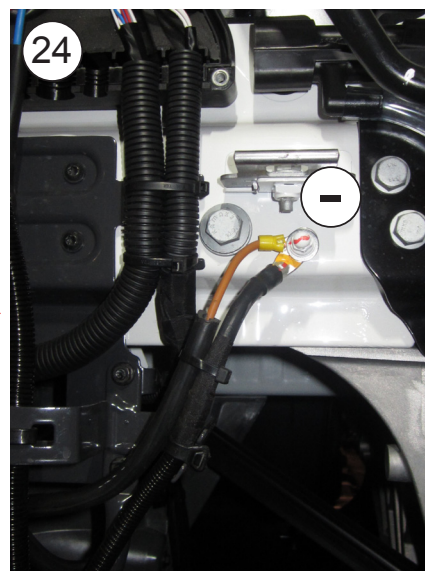
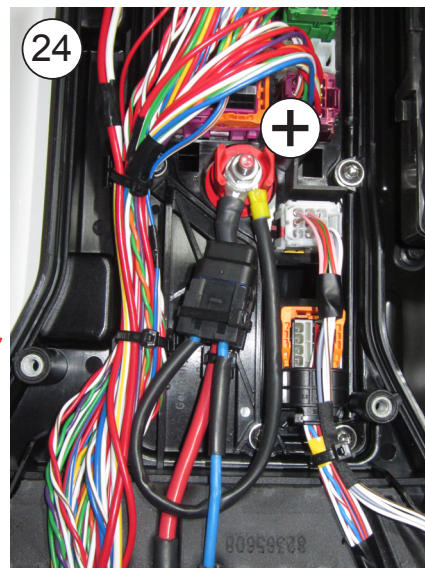

Attenzione: prima di mettere in funzione l'impianto occorre attendere almeno un'ora dopo aver rimesso la cabina in posizione di marcia.

Cablaggio elettrico

AVVERTENZA IMPORTANTE!

Fare attenzione a non invertire le polarità quando si esegue il collegamento dell'impianto. Infatti, in tal caso il quadro comandi non si accende e l'impianto non funziona.

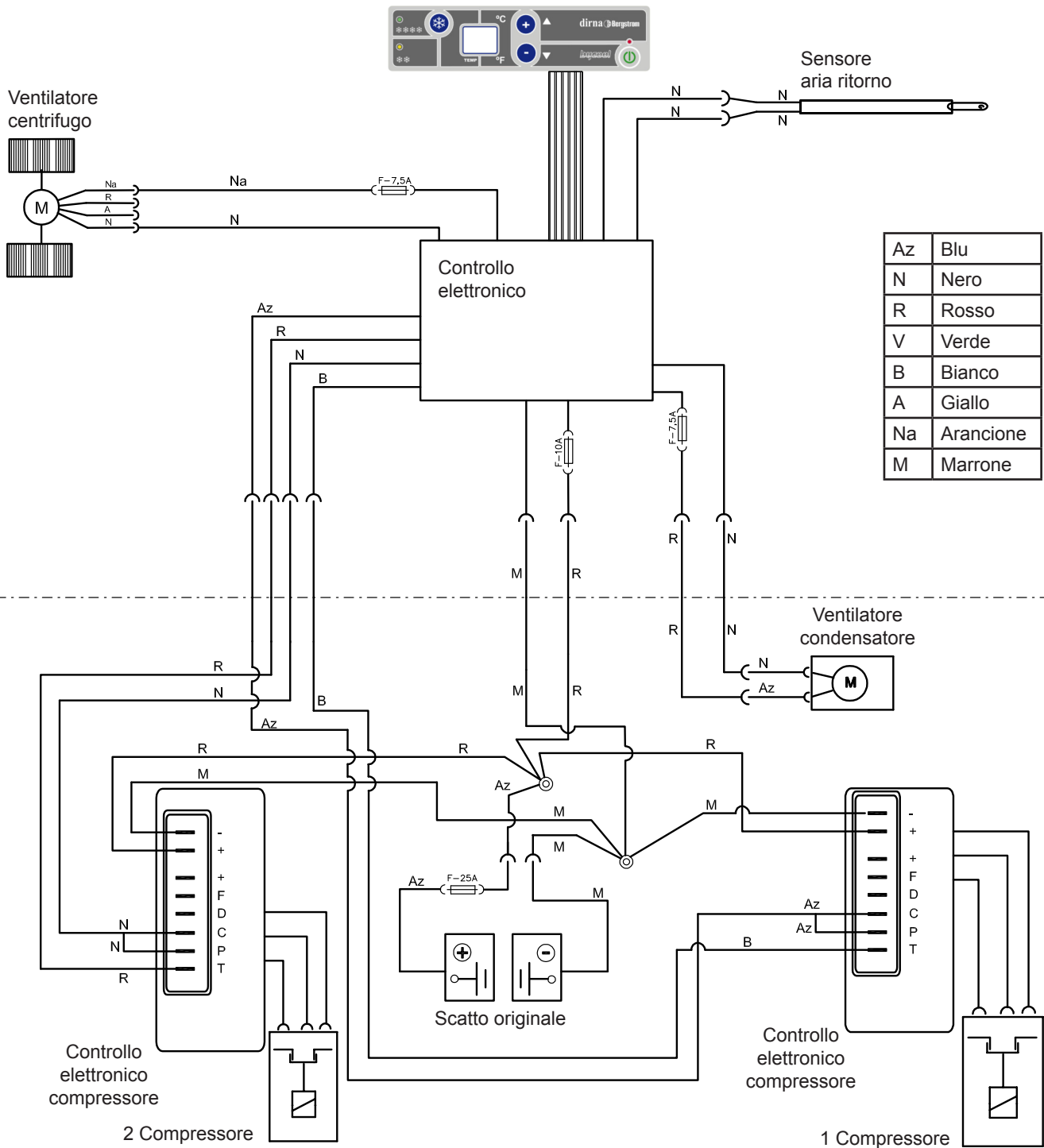

Ed:	07/03/2016
Md:	



Francisco Alonso, 6
28806 Alcalá de Henares, Madrid
SPAIN

Contact	Phone	Fax	E-Mail
Sales (Ventas Internacional)	+34 91 8770510	+34 91 8771158	sales@dirna.bergstrominc.com
Comercial Nacional	+34 91 8775841	+34 91 8836321	ventas@dirna.bergstrominc.com
Orders & Deliveries (Logística internacional)	+34 91 8775846	+34 91 8771158	export@dirna.bergstrominc.com
Orders & Deliveries (Logística nacional)	+34 91 8775840	+34 91 8836321	comercial@dirna.bergstrominc.com
Technical Assistance (Internacional)	+49 511 86679681	+49 511 86679710	technicalassistance@dirna.bergstrominc.com
Technical Assistance (Nacional)	+34 91 8775845	+34 91 883 6321	jcastillo@dirna.bergstrominc.com

www.dirna.com
www.bycool.com

	ATENCIÓN:	Dima Bergstrom se reserva el derecho de efectuar modificaciones en cualquier momento de los datos contenidos en esta publicación, por razones técnicas o comerciales.
	NOTE:	<i>For technical and commercial reasons, Dima Bergstrom reserves the right to change the data contained in this brochure.</i>
	ATTENTION:	Dima Bergstrom se réserve le droit d'effectuer à tout moment des modifications des données reprises sur cette publication, pour des raisons techniques ou commerciales.
	HIWEIS:	<i>Dima Bergstrom behält sich vor, aus technischen oder kaufmännischen Gründen jederzeit Änderungen der Angaben dieser Veröffentlichung vorzunehmen.</i>
	ATTENZIONE:	Dima Bergstrom si riserva il diritto di effettuare modifiche in qualsiasi momento ai dati contenuti in questa pubblicazione, per motivi tecnici o commerciali.