

bijscool!

green line

COMPACT 1.4

IVECO STRALIS EURO 6



Instrucciones de Montaje

Mounting Instructions

Instructions de Montage

Montageanweisungen

Istruzioni di Montaggio

Instrukcje montażu

ES Spanish

EN English

FR French

GE German

IT Italian

PL Polish

Recomendaciones Para el montaje

- Antes de iniciar el montaje leer las instrucciones y seguirlas durante el proceso de instalación.
- Usar las herramientas adecuadas para cada operación.

Electricidad

- Desconectar la llave de contacto.
- Desconectar la batería antes de empezar el montaje.
- Asegurar el conexionado de los componentes eléctricos, verificando su correcto encaje.

Atención

Si durante el montaje el equipo se inclina ó se abate la cabina con el equipo montado, se deberá esperar un mínimo de 60 minutos, desde que el equipo quede horizontal, antes de ponerlo en marcha.

Documentación incluida

Instrucciones de montaje	1001207468
Manual del usuario	220AA60170
Diagnóstico de averías	220AA60013
Garantía	220AA10017

Atención

Al instalar el equipo de aire acondicionado en el techo se debe proteger la parte superior de la cabina con un paño o manta protectora para evitar posibles arañazos. Al instalar **Compact** en el techo hay que tener en cuenta que, normalmente, las cabinas que vienen provistas de escotilla, tienen una estructura suficiente para soportar el peso del equipo. Sin embargo, cuando no ocurra así y sea necesario realizar corte en el techo o incluso si en el caso de llevar escotilla el material no es lo suficientemente resistente (caso de techo de fibra, plástico, etc...) es el instalador el que debe decidir, **bajo su responsabilidad**, sobre la necesidad de reforzar el techo para evitar posibles deformaciones, roturas, entradas de agua, etc... habilitando los medios para que esto no ocurra.

Herramientas

Juego de Llaves Torx

Juego de Llaves Allen

Llave fija 10, 13, 14

Tijeras

Flexómetro

Simbología



Frágil









Atención corte!



Riesgo eléctrico

Advertencias

-  El personal instalador debe poseer una formación suficiente en Aire Acondicionado de vehículos.
-  **dirna Bergstrom, s.l.** queda exenta de responsabilidad si se producen averías que procedan de una inadecuada manipulación o instalación del equipo, o por modificaciones y sustituciones efectuadas sin nuestra expresa autorización por escrito.
-  **Equipo precargado con gas refrigerante. (No manipular el circuito de gas refrigerante).**
-  Véase **procedimiento de garantía** del producto incluido en **Diagnóstico de Averías**.
-  Véase **Manual de Usuario** del equipo para el correcto funcionamiento del mando a distancia y del panel de control.
-  Al finalizar la instalación se debe entregar al usuario: **Manual del Usuario, Garantía y Diagnóstico de averías.**

 Antes de empezar con el montaje, montar rejilla entrada aire delantera.



1 Desmontar tapa escotilla, los elementos de fijación y entregar al cliente (*).

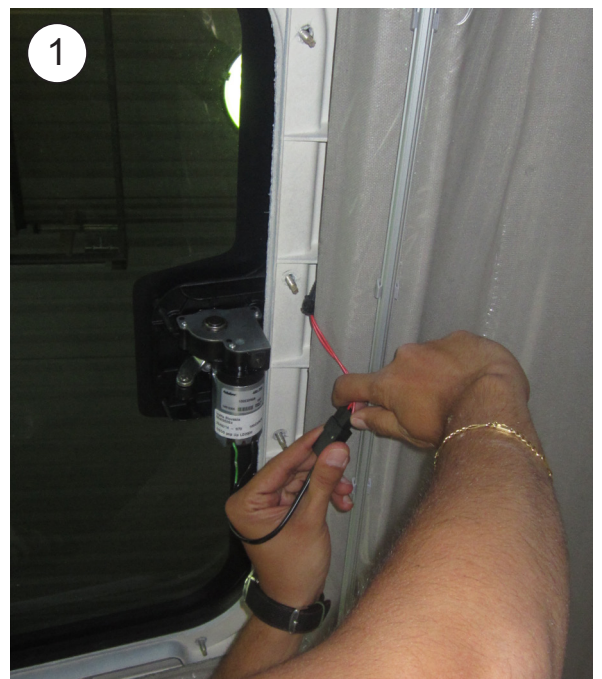

2

Quitar los residuos sobrantes adheridas al techo antes de pegar la junta EPDM.

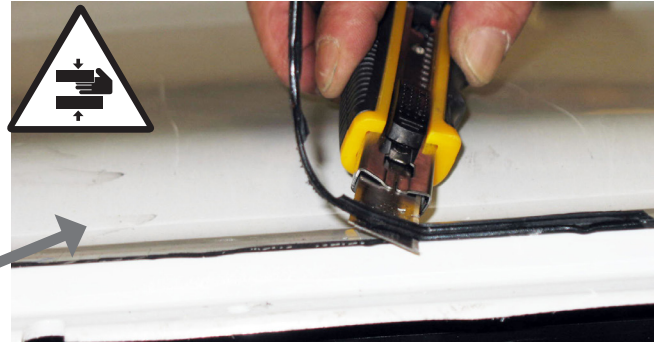

2a

Pegue la junta EPDM alrededor del hueco de escotilla (*mirar el detalle para cortar los bordes finales de unión de la junta*).



COMO CORTAR LA JUNTA EPDM PARA EVITAR FILTRACIÓN DE AGUA EN LA CABINA

- A- Pegar la junta, manteniendo 100 mm de papel protector por cada lado.
- B- Quita los dos piezas de papel.
- C- Pegue presionado ambos finales.

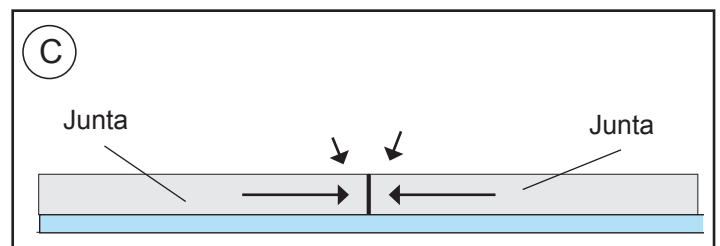
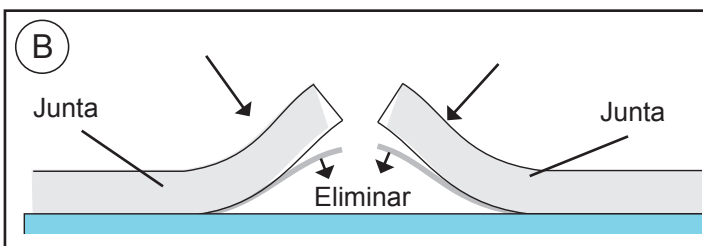
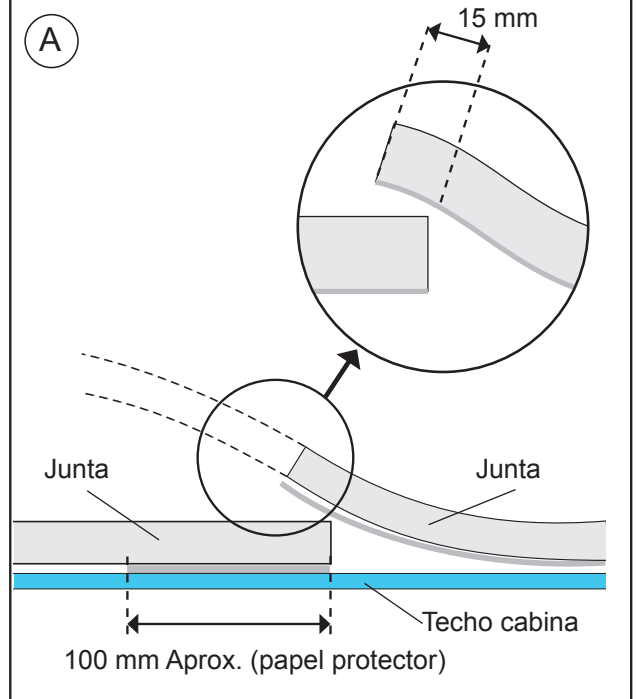

3

EXTERIOR CABINA:

Posicionar el Compact en el hueco de la escotilla.

¡Atención! Al colocar el equipo encima del hueco escotilla, revisar que las salidas de desagüe no queden obstruidas por la junta EPDM.

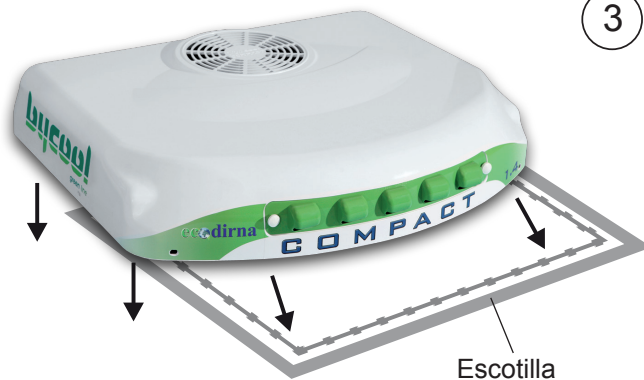

3

4

Colocar canalizador gomaespuma quedando la parte más blanda en la base del equipo.

Atención: Dependiendo de la cabina, es posible que sea necesario usar los (2) canalizadores suministrados para que el panel de distribución de aire quede totalmente ajustado con ellos.



4

5

INTERIOR CABINA:

Roscar 5 mm aproximadamente (4) espárragos 8/125x100.

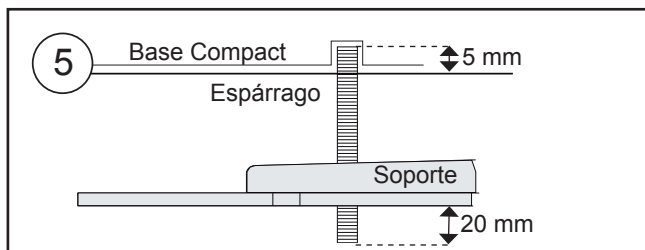

5

5

6

Colocar (1) arandela Ø 7 de goma, (1) arandela plana Ø 8 ala ancha, (2) tuerca M8 y (1) arandela plana Ø 8 ala ancha , en cada uno de los espárragos anteriores; siguiendo dicho orden.

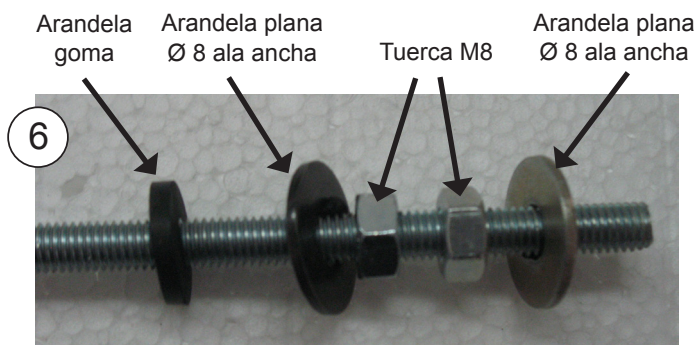

6

7 Colocar (2) soportes sujeción, con (1) arandela y (1) tuerca autoblocante M8, **sin llegar a apretar.**



8 Roscar 10 mm (4) espárragos M6 x 55 ó 80, donde se indica, según distancia (D) del esquema del punto 17.

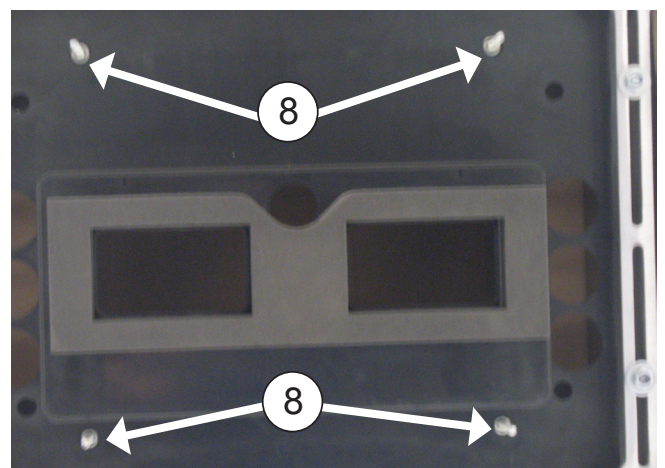
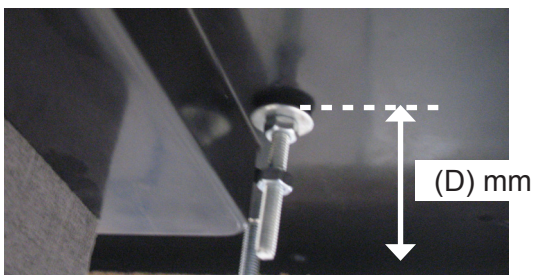

9 Colocar (1) arandela Ø6 de goma, (1) arandela plana Ø6 ala ancha y (1) tuerca M6, sobre cada uno de los espárragos de M6. **Apretar tuerca**, a continuación apretar tuerca hasta que la arandela de goma quede un poco oprimida.

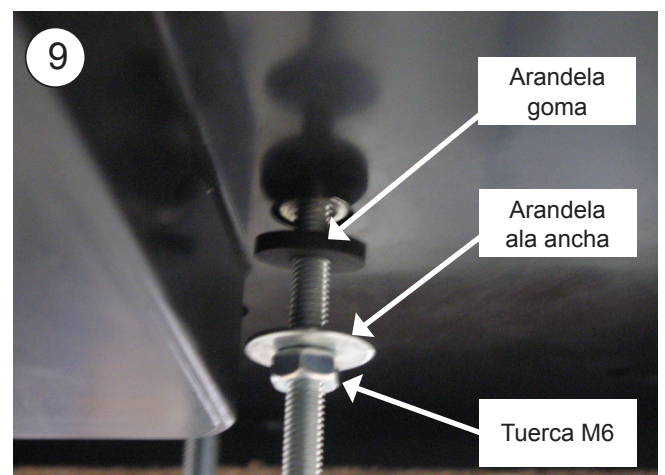

10 Colocar (1) tuerca M6 **sin apretar** en cada espárrago.

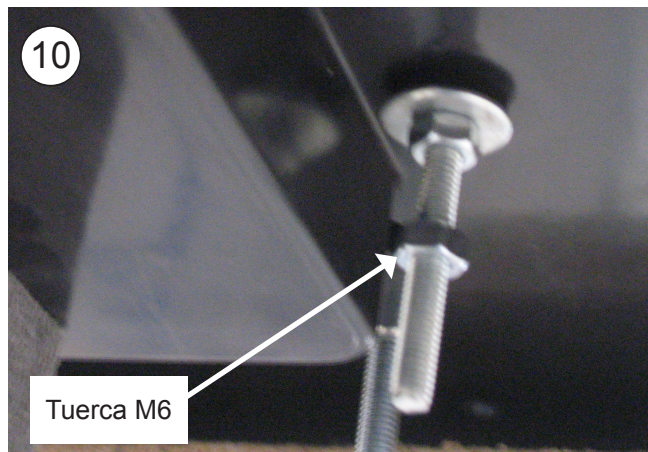
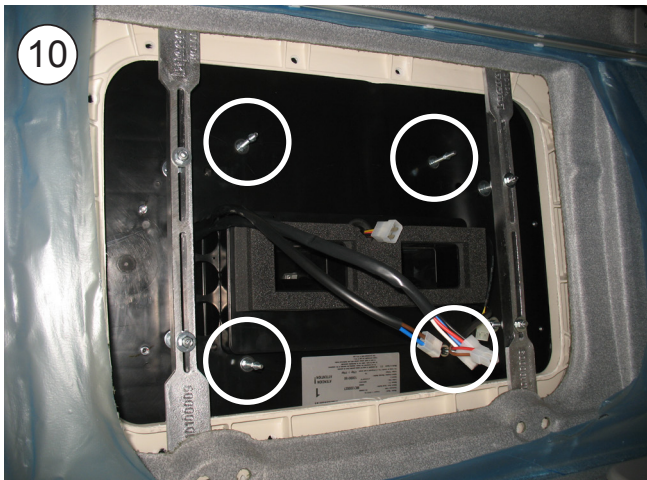

11 Conectar la caja de 2 vías del sensor del aire de retorno, la caja de 4 vías del soplador y la de 8 vías de conexión de los cableados del control electrónico.

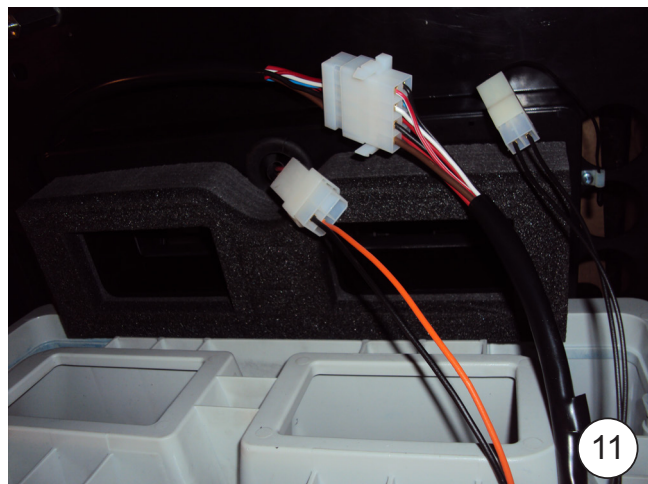

12

Colocar el panel interior de distribución de aire en los espárragos anteriores con (1) arandela M6 ala ancha y (1) tuerca M6 en cada espárrago. Apretar tuercas hasta que el canalizador del panel interior de distribución de aire haga tope en goma espuma superior del equipo.

Importante: El canalizador del panel interior de distribución de aire debe hacer tope contra la goma espuma superior del equipo para evitar fugas de aire.

Tener la precaución de no pillar los cableados entre el canalizador y la gomaespuma colocada en la base del equipo.

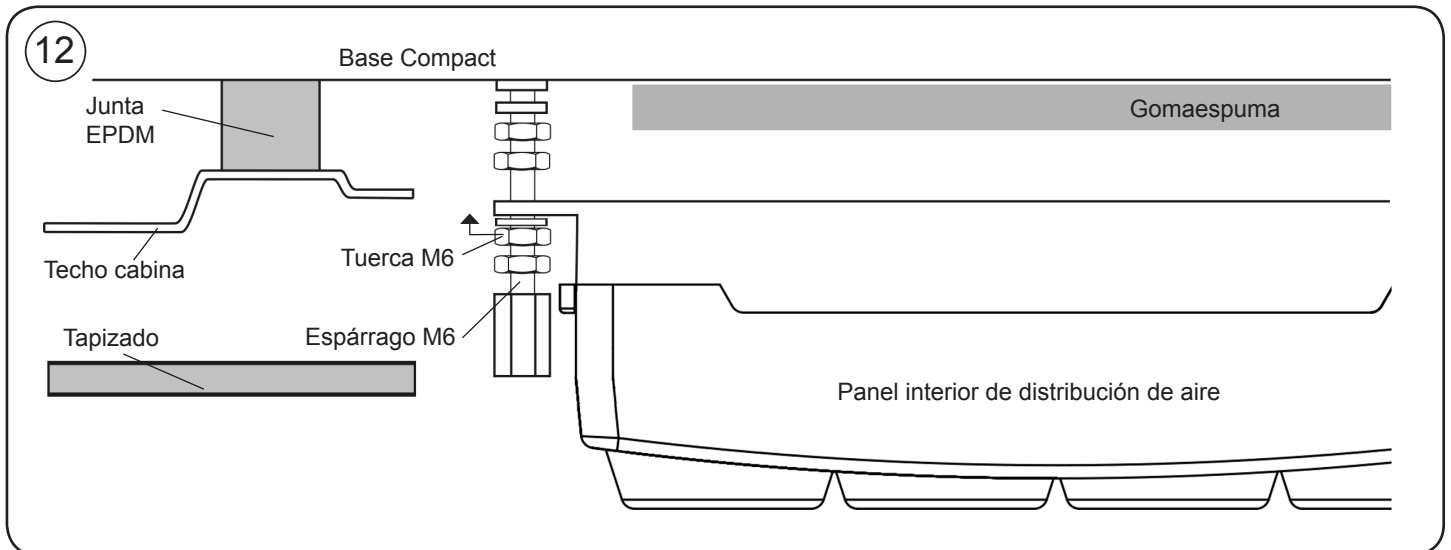

13

Apretar tuerca del punto 10 hasta hacer tope con la parte superior del panel interior de distribución de aire.

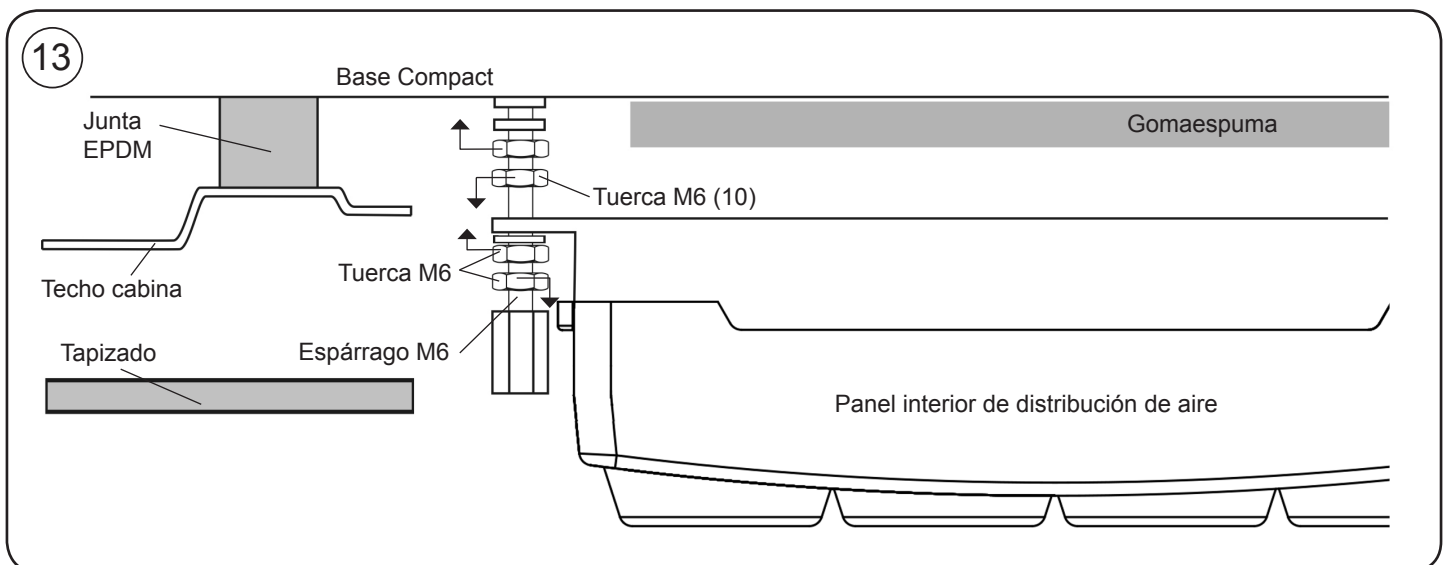

14

Presentar consola y centrar el equipo en el sitio más conveniente del techo de la cabina. Una vez centrado quitar consola.



15

Fijar los soportes de sujeción apretando las tuercas hasta el apriete de la junta de EPDM exterior del equipo entre 3 y 6 mm.

Importante: Para evitar posibles filtraciones de agua al interior de la cabina se debe asegurar el apriete de la junta EPDM con la base del Compact tal y como se indica en el esquema.



Comprobar la compresión de la junta EPDM usando un flexómetro en las cuatro esquinas.

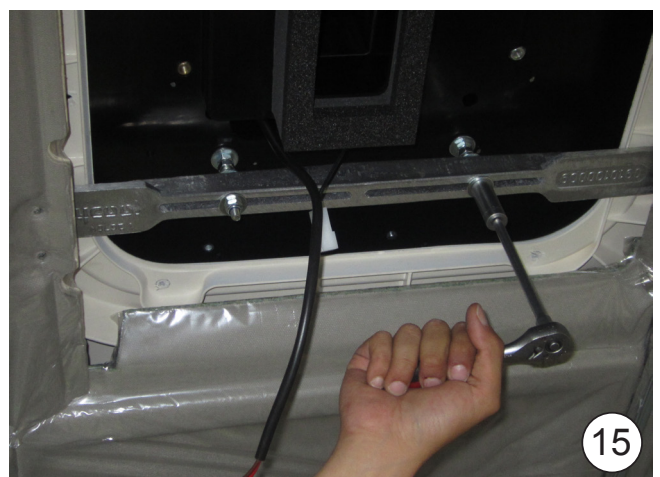
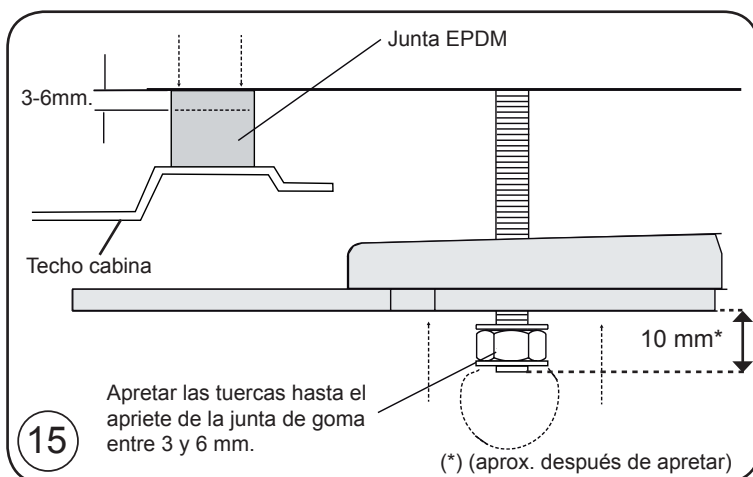

16

Apretar (4) tuercas M8 al soporte y (4) a la base del Compact.



16

17

Colocar tuerca M6 (A) tras la tuerca de fijación del panel interior de distribución de aire en cada espárrago. Colocar hexágonos M6 roscándolo hasta que quede 1 mm por encima del tapizado. Desenroscar tuercas M6 (A) de este punto hasta que haga tope con los hexágonos y apretar contra estos.

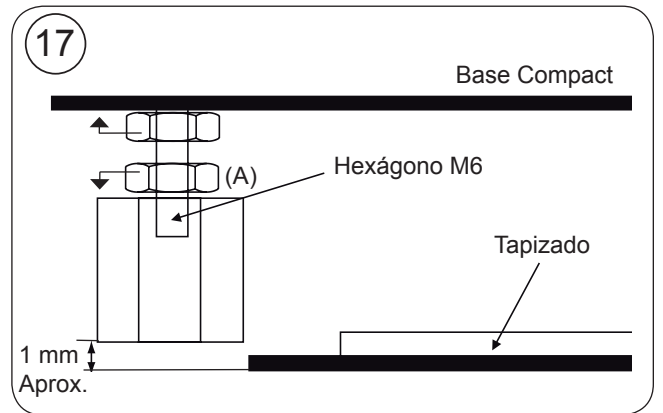

17

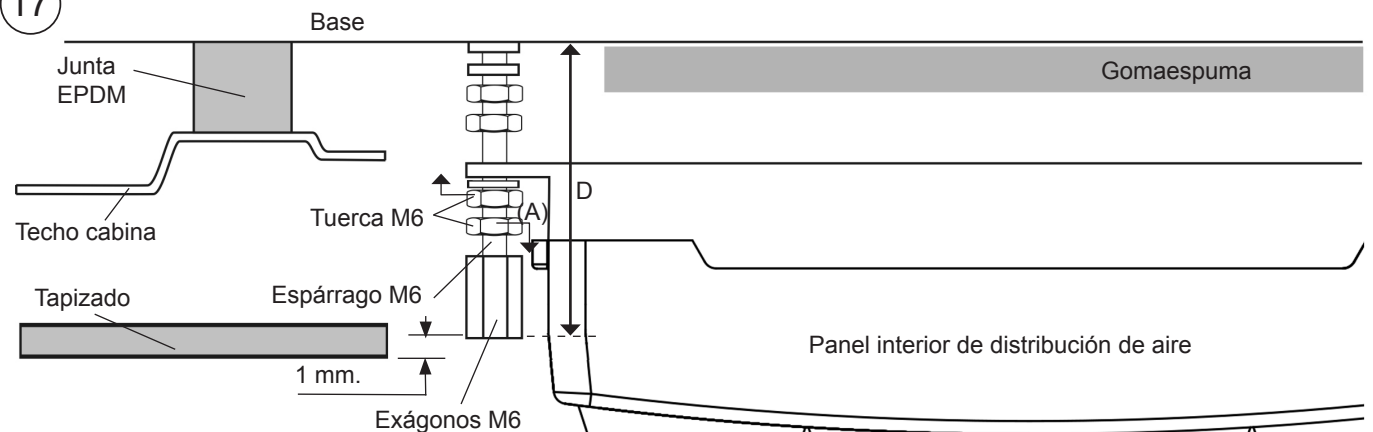

18 Colocar la consola con (4) tornillos M6/100x15 allen.



19 Cubrir los (4) tornillos M6/100x15 allen con los embellecedores redondos de M6 de plástico.



20

Roscar (4) tornillos 6/100x15 en embellecedor consola original y tapar estos con tapón tuercas.



Vista explosionada hasta la fijación de los soportes

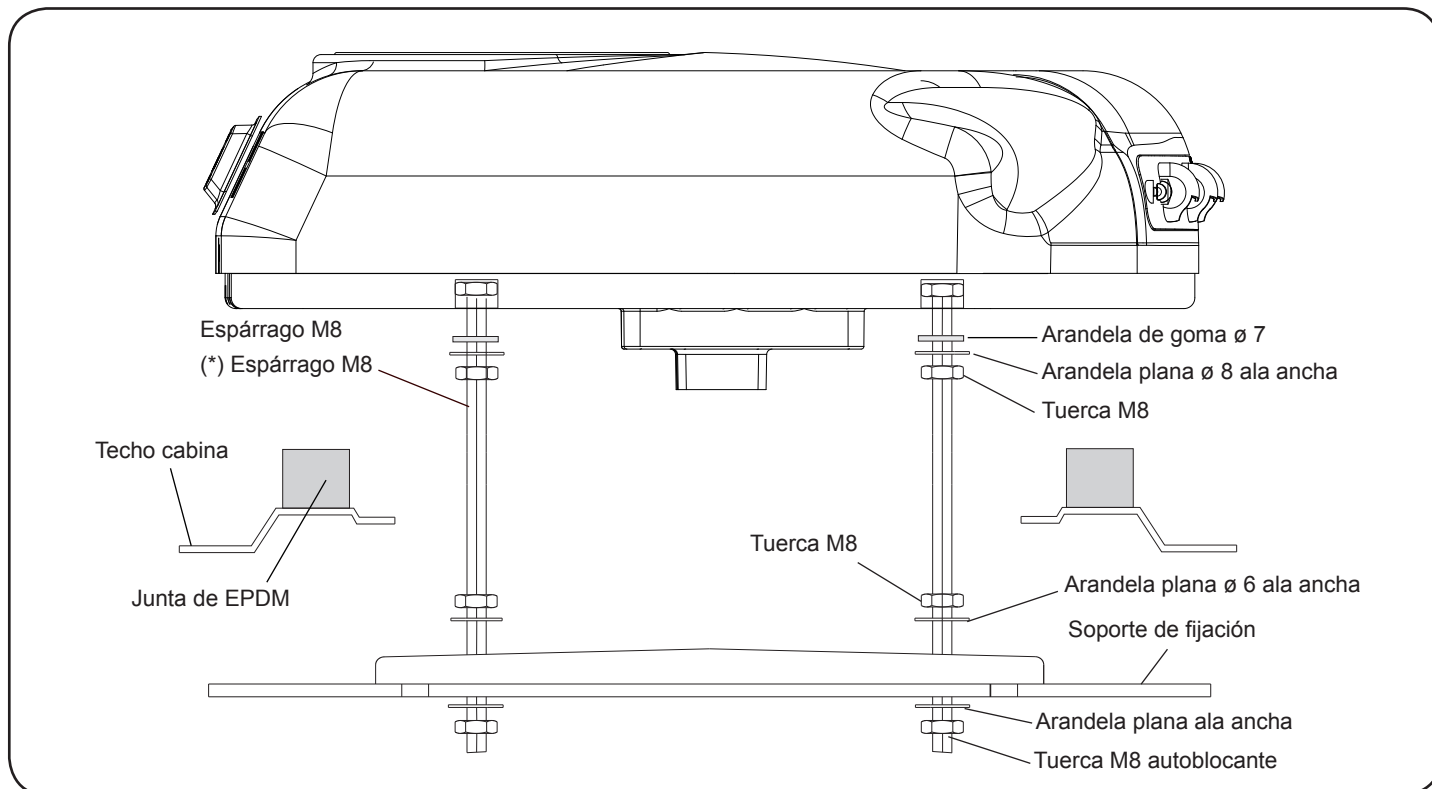

Vista explosionada hasta la fijación de las consolas

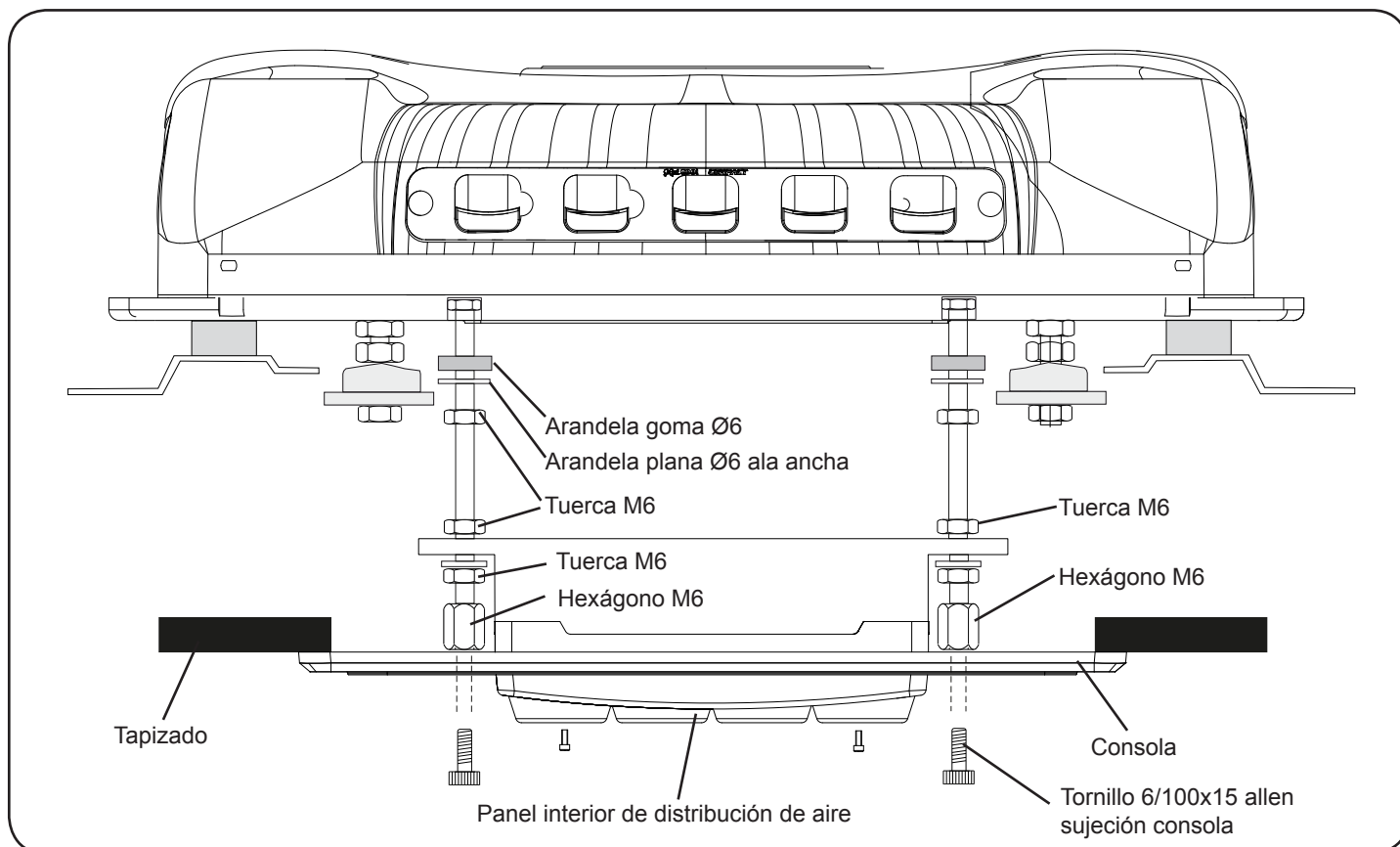

Instrucciones detalladas sobre la instalación del cableado de alimentación

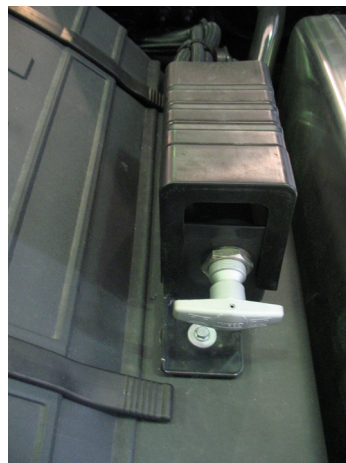
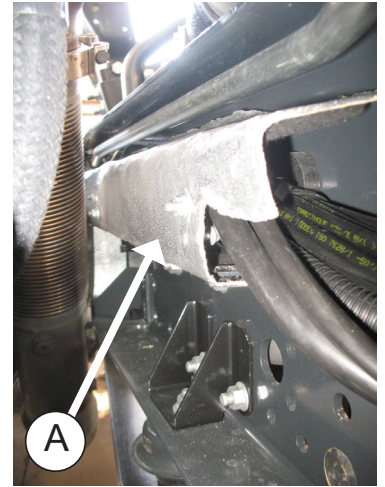

- 1 Llevar el cable de alimentación del equipo hasta corta corriente (positivo) y punto de masas (negativo) del vehículo, pegando los soportes de plástico en la parte posterior de la cabina y fijándolo con bridas; después con la cabina abatida pasar el cable por la parte inferior de la misma sujetándolo con abrazaderas y tornillos M4; y hasta la batería con bridas; se debe utilizar el mismo paso del cableado original (por dentro de la protección del tubo de escape (A)). *(Para pegar los soportes de plástico limpiar bien la zona antes)*. Al conectar el equipo a la batería éste hará un test en todos sus leds, aparecerá en el display **88-bd** y se apagará.



IMPORTANTE: Para la puesta en marcha consultar el Manual del Usuario.

Esquema eléctrico

¡AVISO IMPORTANTE!

Precaución de no invertir las polaridades al conectar el equipo a la batería. Si esto sucediera la placa de mandos no se enciende y el equipo no funciona.

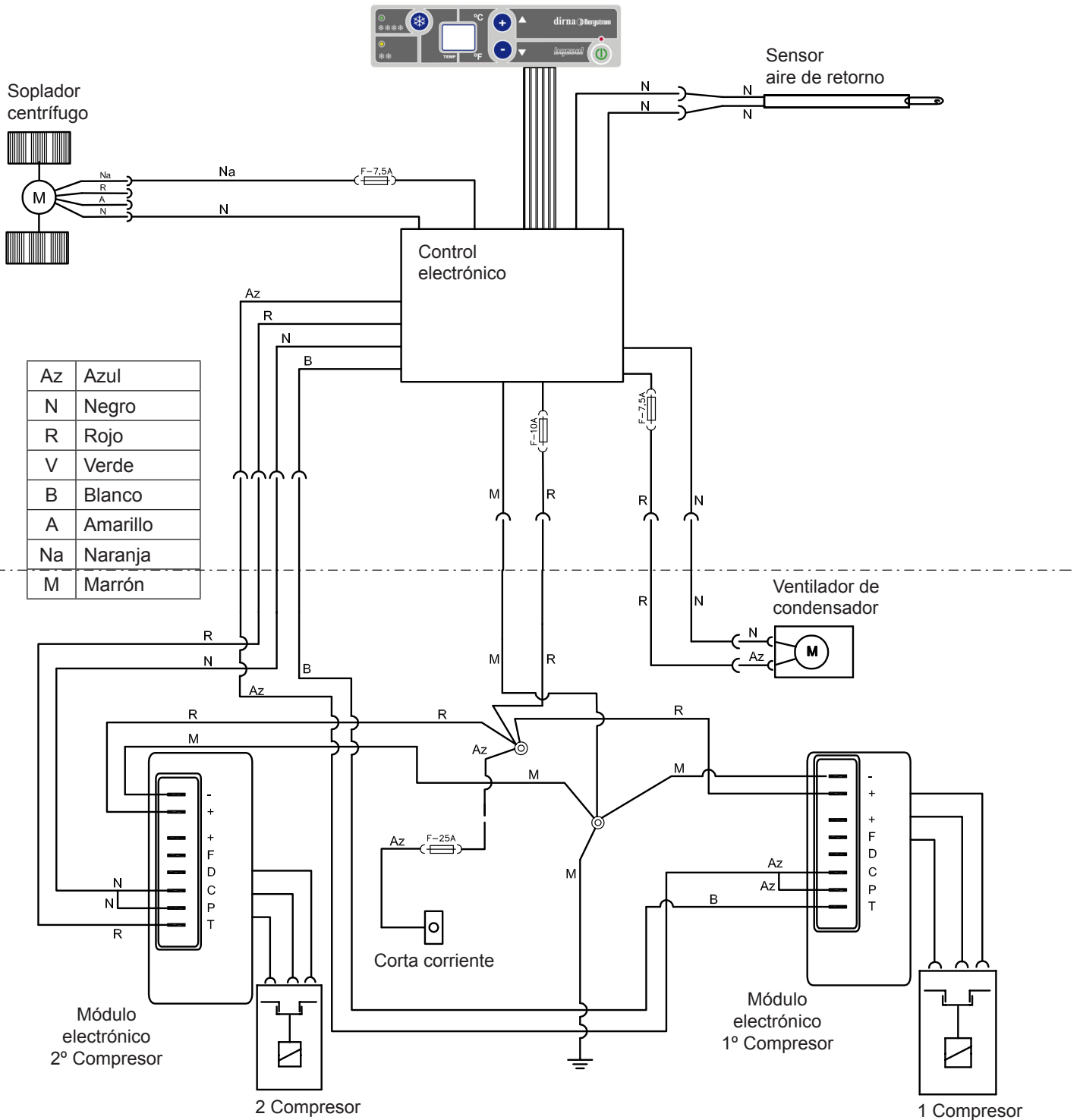

Assembly Recommendations

- Before starting assembly, please read instructions and follow them during installation process.
- Use the adequate tools for each operation.

Electricity

- Disconnect ignition key.
- Disconnect battery before starting assembly.
- Make sure electric components are securely connected, checking their correct fitting.

Warning

If the unit slants during assembly, wait for at least 60 minutes with the unit in horizontal position before starting it up.

Documentation included

Mounting instructions	1001207468
User's guide	220AA60170
Troubleshooting	220AA60013
Warranty	220AA10017



Warning

When installing air conditioning equipment on roof, the upper cabin part must be protected with a cloth or a protective blanket to avoid possible scratches. When installing **Compact** on roof, take into account that, normally, cabins equipped with a hatch have a strong enough structure to hold equipment weight. However, if it is not the case and it is necessary to carry out a cut in the roof or, although it has a hatch, the material is not resistant enough (*if roof is made of fibre, plastic, etc...*), it is the installer who will have to decide, under his responsibility, if it is necessary to reinforce the roof to avoid possible deformations, breaks, water entries, etc., habilitating the means required to stop it from occurring.







Tools

- Torx wrenches set
- Allen wrenches set
- Open-jawed spanner 10, 13, 14
- Scissors
- Flexo-meter

Symbology

-  Fragile
-  Beware of cuts!
-  Electrical hazard

Warnings

-  The installing personnel must have a sufficient training in vehicles air conditioning.
-  **dirna Bergstrom, s.l.** shall not be responsible for breakdowns or damages coming from an inadequate handling or installation of the equipment or from modifications and substitutions carried out without our express and written authorisation.
-  **Equipment pre-charged with refrigerating gas. (Do not handle refrigerating gas circuit).**
-  Please see product **warranty procedure** included in **Troubleshooting**.
-  Please see equipment **User's Guide** for its correct functioning of the remote control and control panel.
-  Once installation is finished, the following documents must be handed over to the user: **User's Guide, Warranty and Troubleshooting**.

 Mount the front air input grille before starting assembly.



1 Dismantle hatch cover as well as fastening elements and hand in to customer (*).

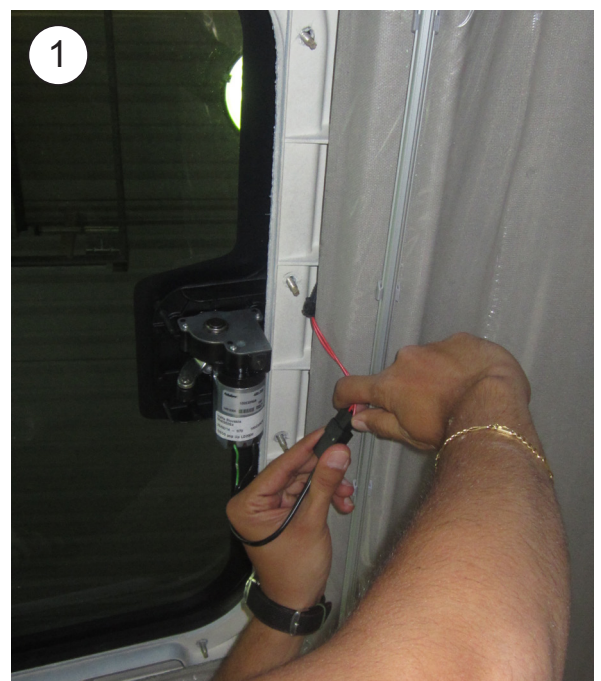

2 Remove residual glue substance of the roof upper surface before glueing EPDM gasket.

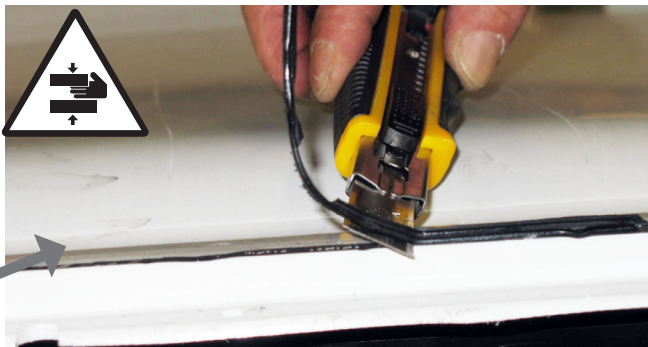

2a Glue EPDM gasket around hatch hole (see detail for cutting end join edges).

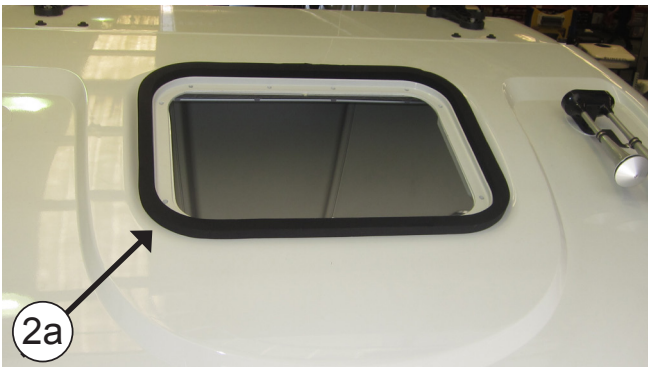

! HOW TO CUT EPDM GASKET TO AVOID WATER FILTRATION INTO THE CABIN

- A-** Glue gasket, keeping 100 mm of protection paper at each side.
- B-** Remove the two pieces of paper.
- C-** Glue by pressing both ends.

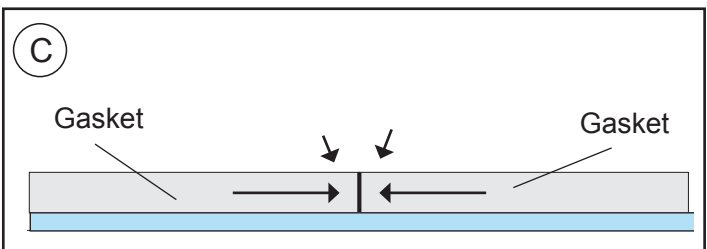
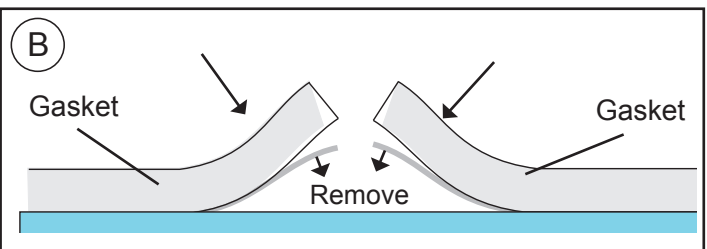
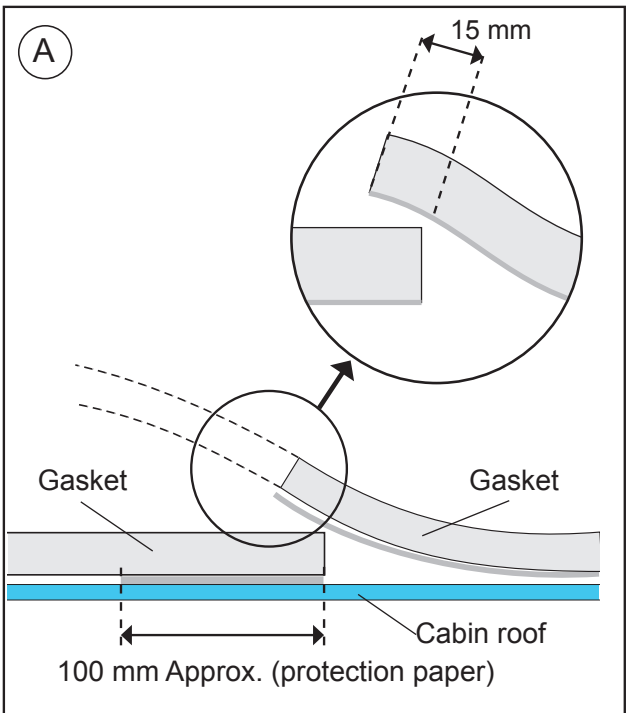

3 **OUTSIDE CABIN:**
Position Compact in sun hatch hole.
Caution! When positioning the unit above the hatch gap, check that the wastewater run-offs are not blocked by the EPDM seal.

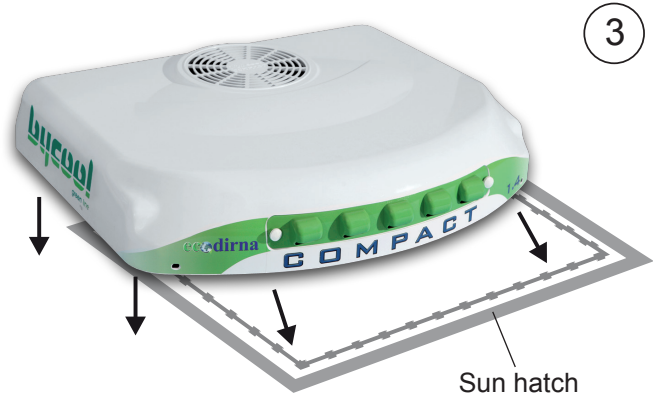

4 Position the foam rubber, ensuring the softest part is placed on the base of the unit.
Caution: Depending on the cabin, it may be necessary to use the (2) supplied ducts in order for the distribution panel to be completely adjusted.



5 **INSIDE CABIN:**
Screw about 5 mm (4) 8/125x100.

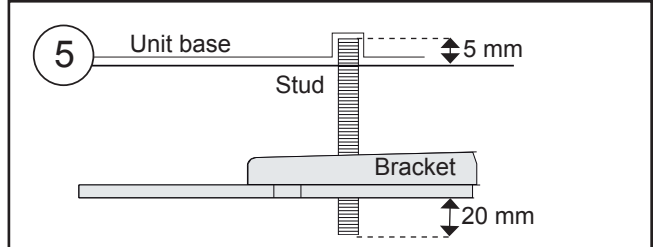

6 Following this order:
• Ø 7 plane rubber wash
• Plane rubber wash wide wing diameter 8
• Nut M8
• Plane washer diameter 8 wide wing

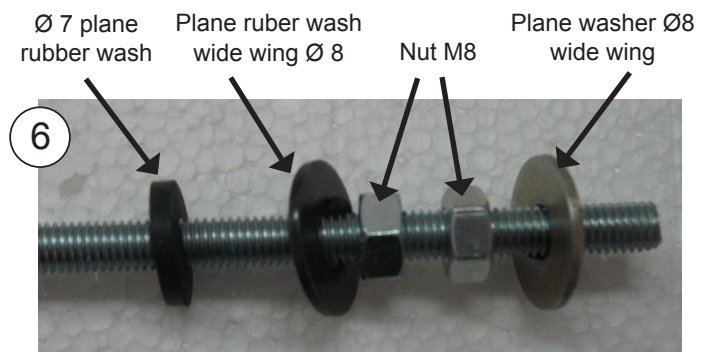

7 Place (2) fastening supports, with (1) washer and (1) M8 self-blocking nut, **without tightening**.



8 Screw 10 mm deep (4) M6 x 55 or 80 studs, where indicated distance (D) in figure point 17.

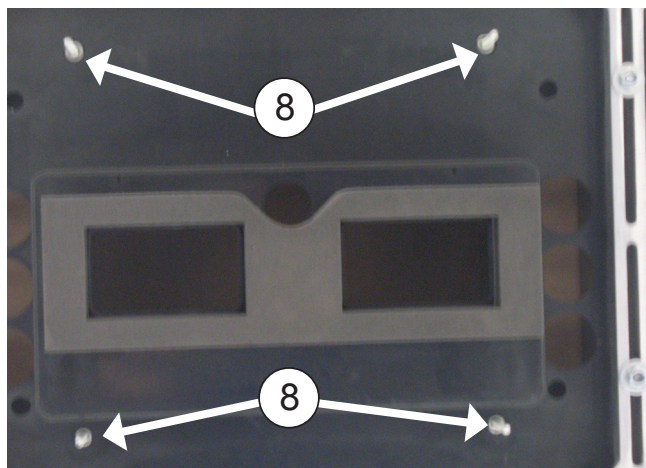
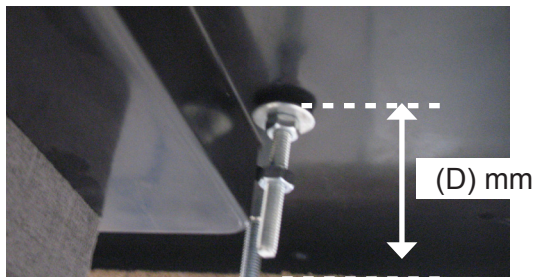

9 To place (1) rubber washer diameter 6 (1), plane washer diameter 6 wide wing and (1) nut M6, over each of the spigots of M6. After, to tight the nut til the rubber washer remain a little tight.

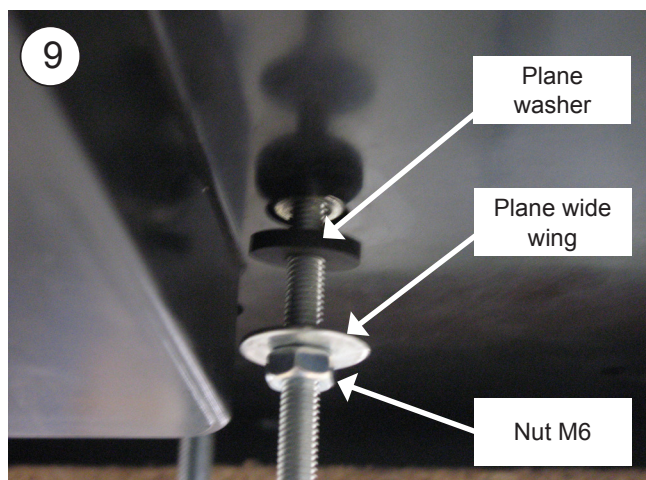

10 Place (1) nut M6 **without tight** in each stud.

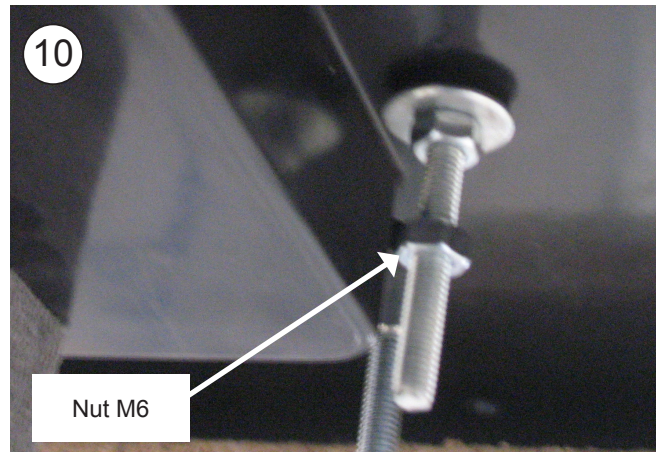
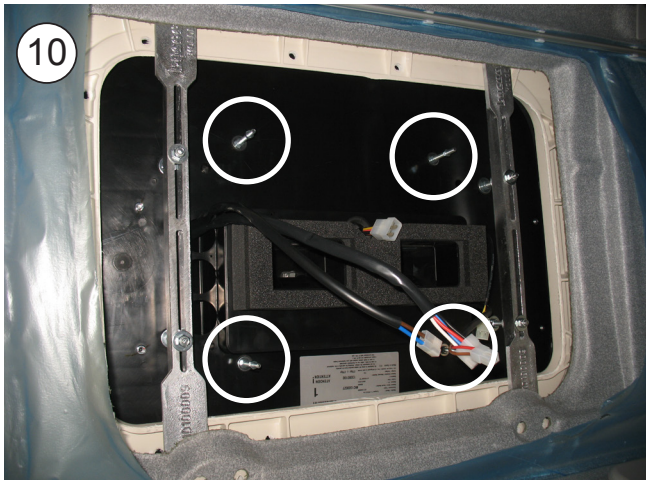

11 Connect the return air sensor 2-way box, the blower 4-way box and the electronic control cable connection 8-way box.

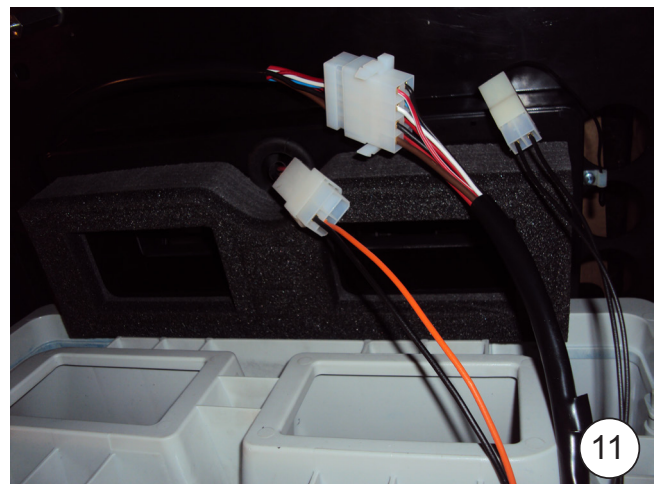

12

Position the interior air distribution panel on the front studs with (1) M6 wide-flanged washer and (1) M6 nut on each stud. Tighten the nuts until the interior air distribution panel duct comes up against the unit's top foam.

Important: The interior air distribution panel duct must come up against the unit's upper foam in order to prevent any leakages of air.

Take care to ensure the cables do not become trapped between the duct and the foam in the base of the unit.

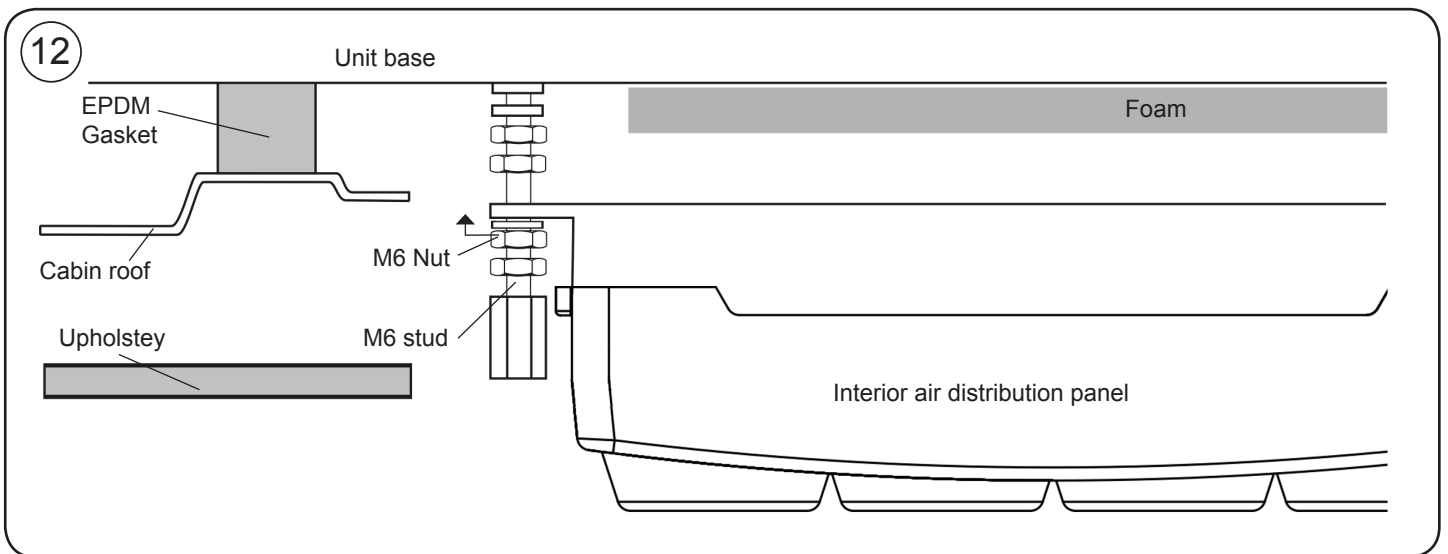

13

Tighten the nut in point 10 until it comes up against the top part of the interior air distribution panel.

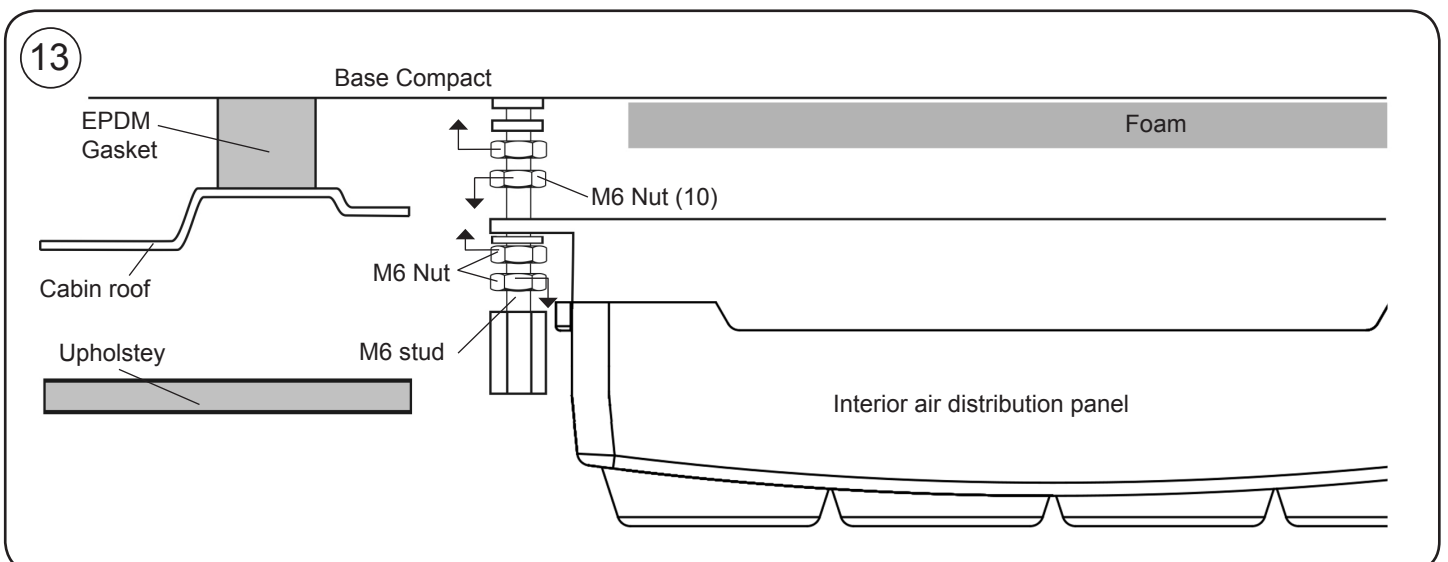

14 Place console and centre equipment in the most convenient place of cabin roof. Once centred, remove console for later installation.



15 Fasten supports tightening nuts until outside EPDM joint of equipment is compressed, between 3 and 6 mm.

Important: To avoid water from filtering inside cabin, check EPDM joint tightening with unit base, as indicated on diagram.



Check compression thickness using a tape measure in the four corners.

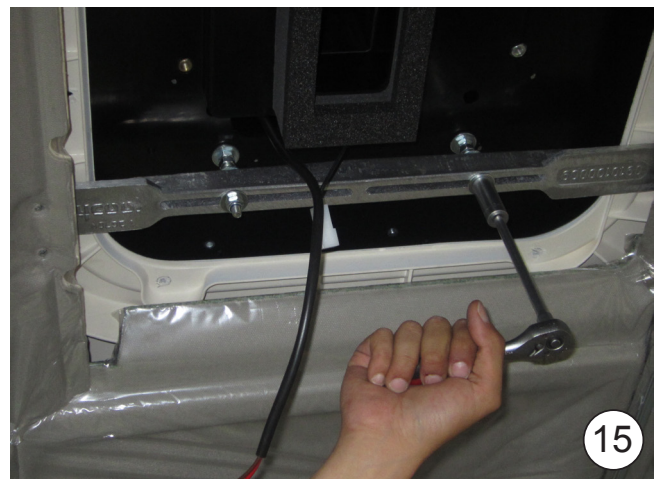
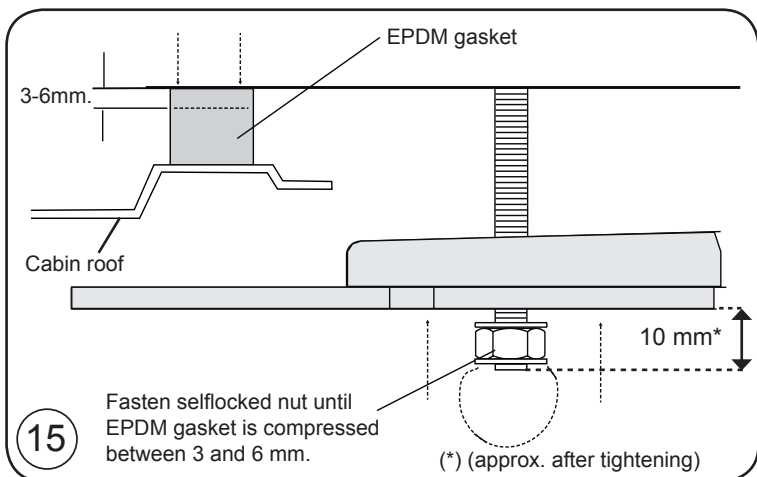

16 Tighten (4) M8 nuts to support and (4) to Unit base.



17 Position nut M6 (A) after the fastening nut of the interior air distribution panel on each stud. Screw on M6 hexagons up to 1 mm above the upholstery. Unscrew M6 nuts (A) of this point until they come into contact with the hexagons, and tighten against them.

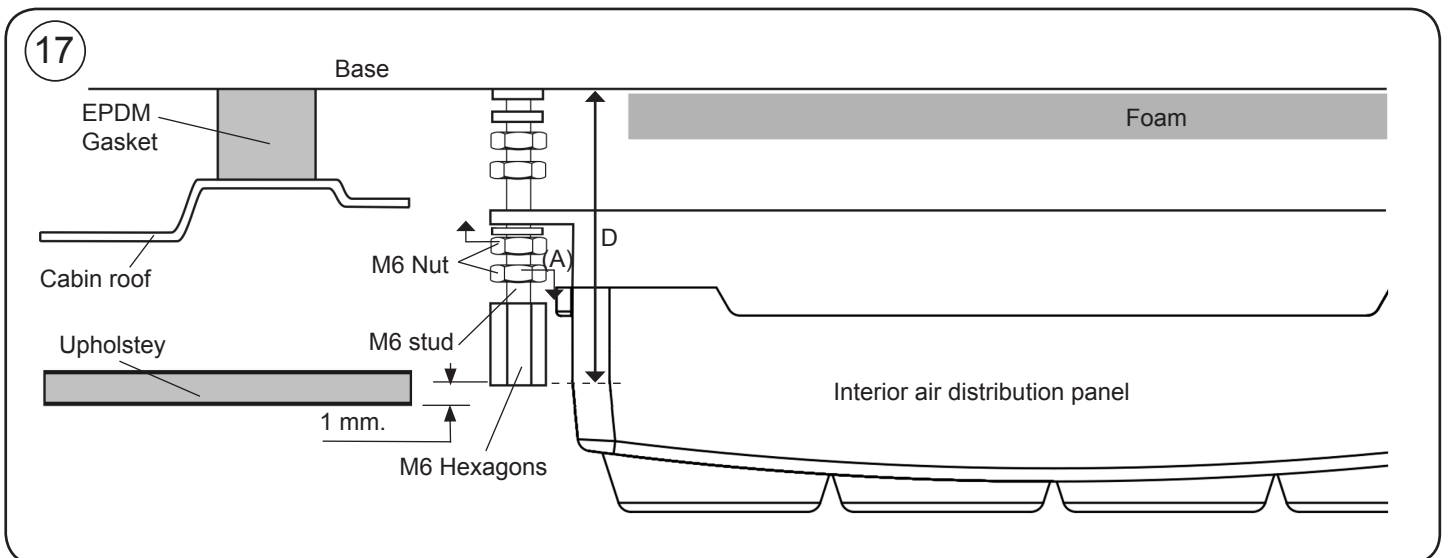
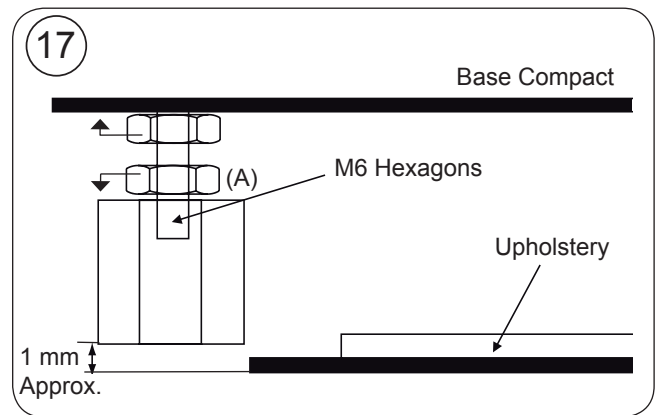

18 Place console using (4) M6/100x15 allen head screws bolts.

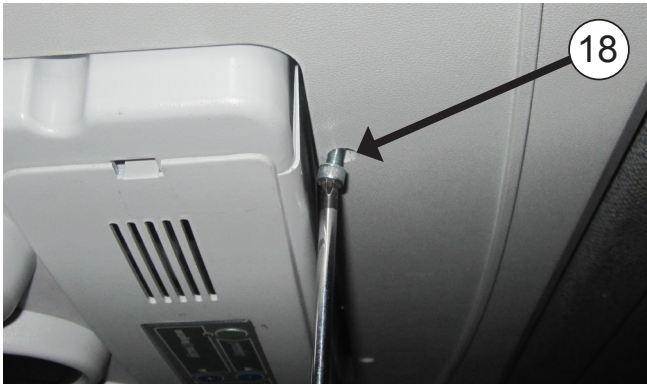

19 Cover the (4) nuts M6/100 x 15 allen with the round protection caps of M6 plastic.



20

Screw (4) 6/100x15 screws in the original console decorative cover and insert the screw caps.



Exploded side view to supports fastening

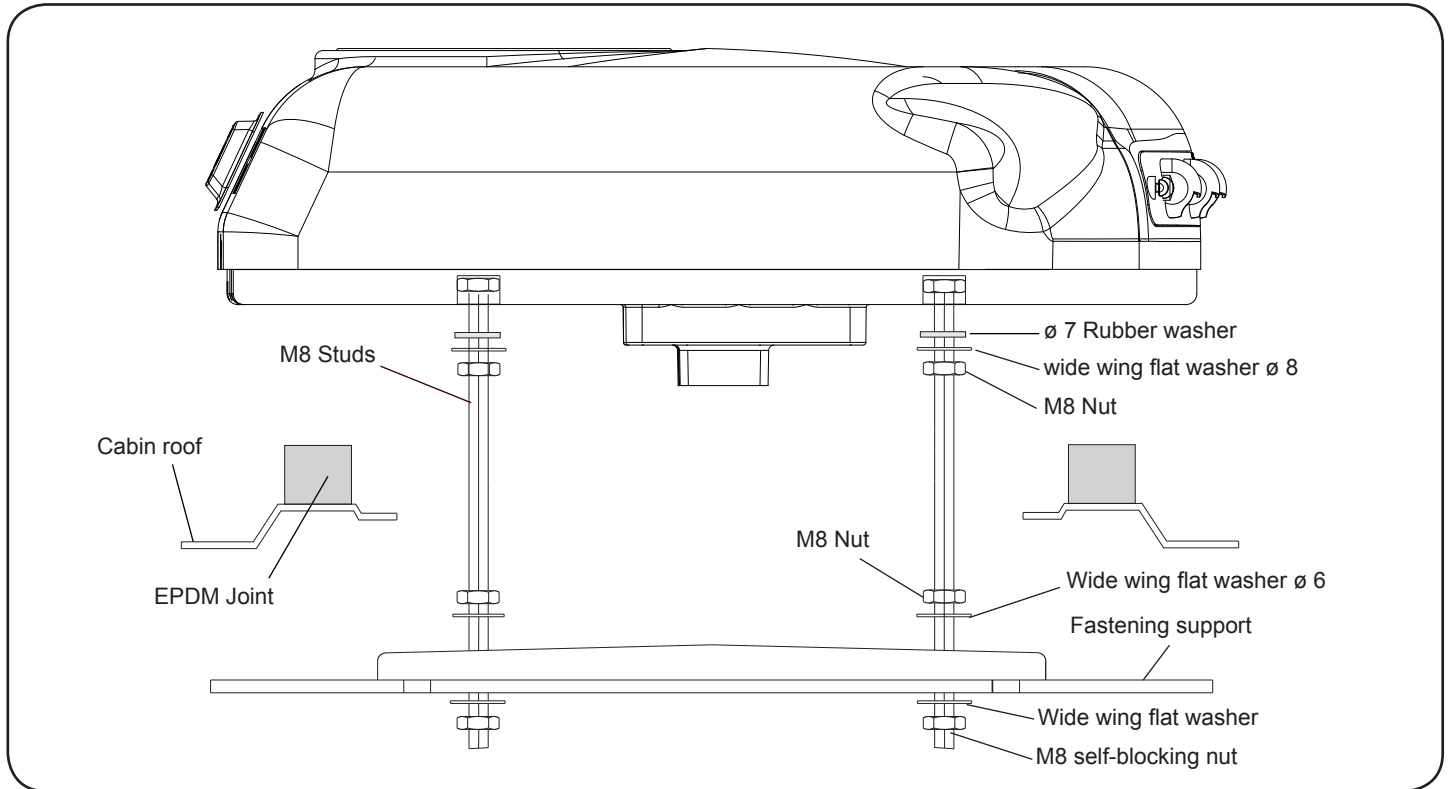

Exploded rear view to consoles fastening

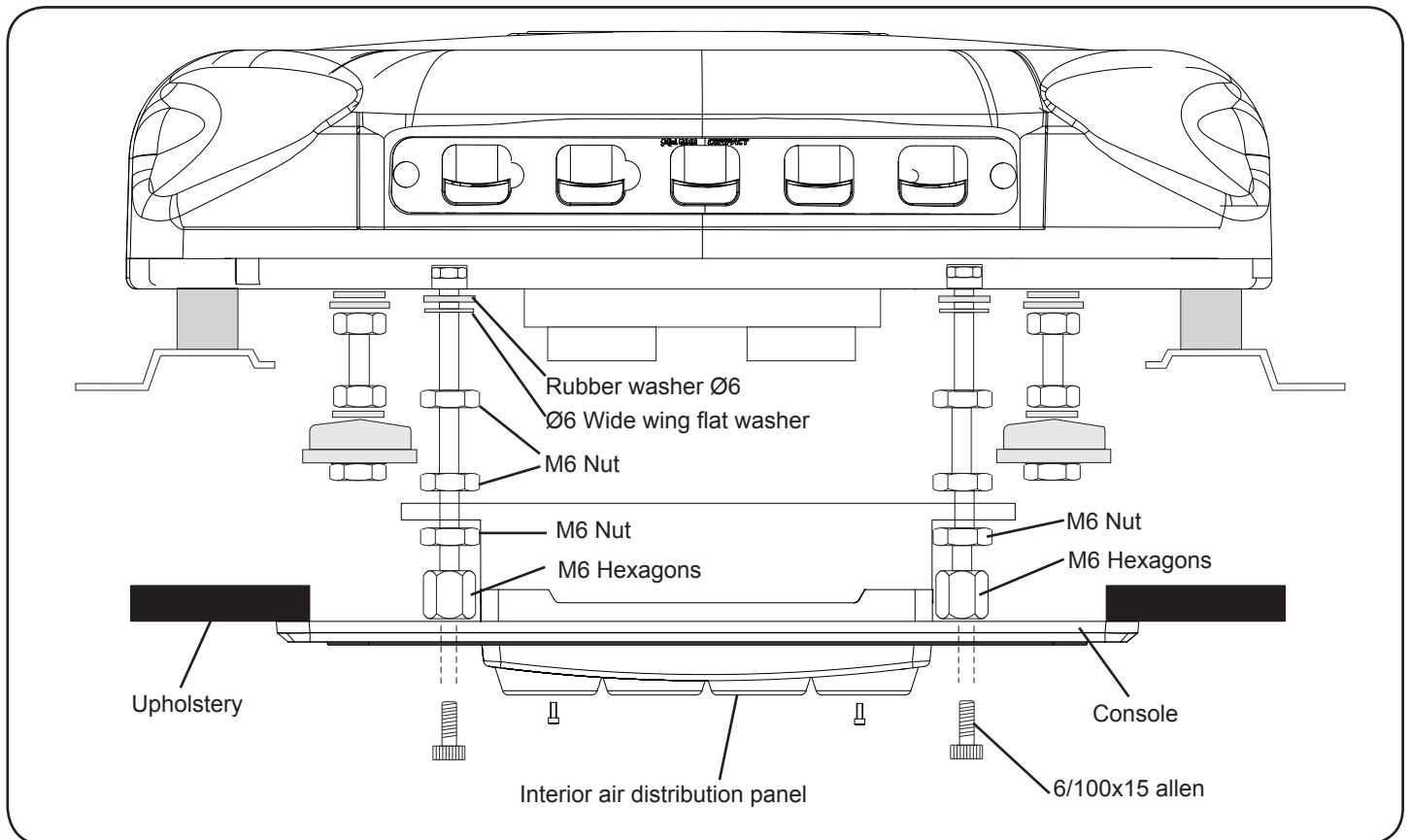

Detailed instructions
on power wiring assembly

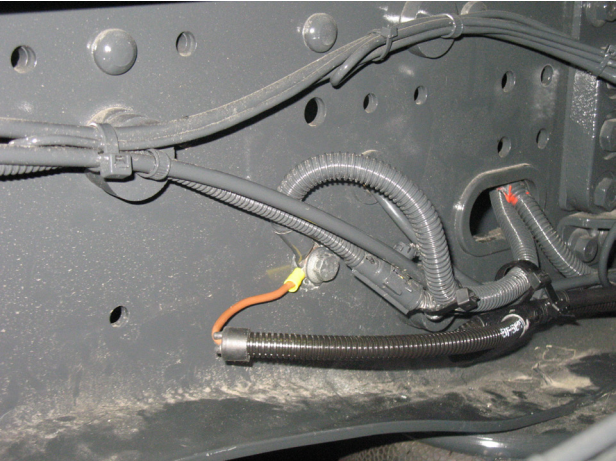
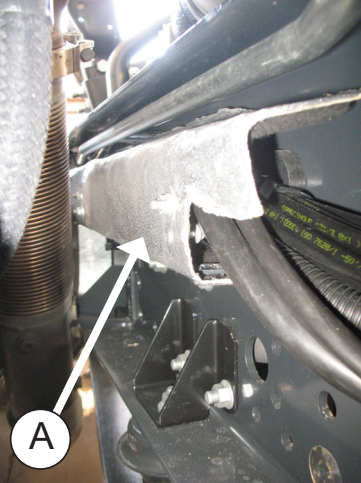
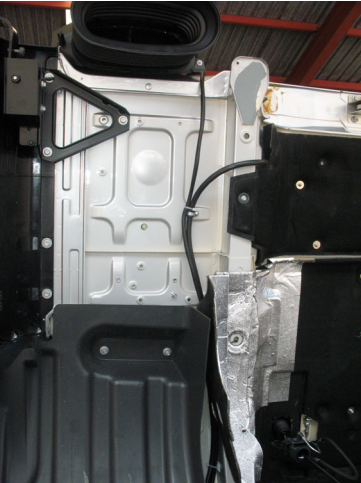

- 1 Take the power cable from the unit through to the vehicle's current breaker (positive) and grounding (negative), attaching the plastic supports to the rear of the cabin and securing with flanges; then, with the cabin tilted, pass the cable through the bottom, securing it with clamps and M4 screws; and through to the battery with flanges; use the same passage as the original cabling (inside the exhaust pipe protection (A)). (Clean the area thoroughly before attaching the plastic supports). When the unit is connected to the battery, this will carry out a test of all the LEDs, displaying **88-bd** and then going off.



IMPORTANT: Check the User Manual before starting up.

Electric wiring

IMPORTANT WARNING!

Take care not to invert polarities when connecting the unit. If this were to happen, the control plate will not come on, the unit will not work.

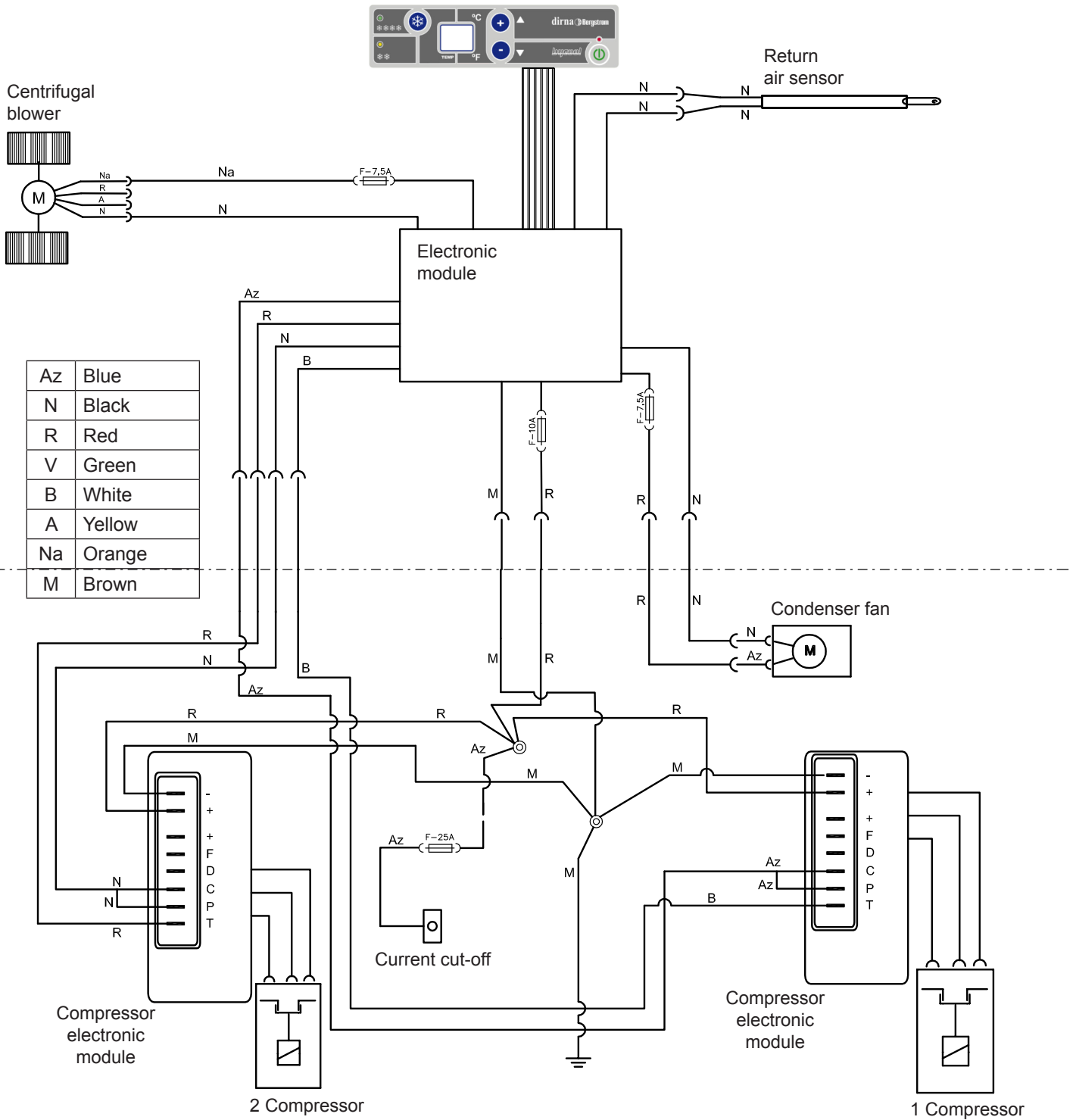

Recommandations Pour Le Montage

- Avant de commencer le montage de l'appareil, prière de lire les instructions et de les suivre attentivement.
- Utiliser les outils convenant à chaque opération.

Electricity

- Déconnecter la clé de contact.
- Déconnecter la batterie avant de commencer le montage.
- Vérifier le câblage des composants électriques et leur correcte installation.



Attention

Si pendant le montage l'équipement est incliné, il faudra attendre au moins 60 minutes avant de le mettre en marche une fois qu'il aura été remis sur sa position horizontale.

Documentation included

Instructions de montage	1001207468
Guide de l'utilisateur	220AA60170
Solution des problèmes	220AA60013
Garantie	220AA10017



Attention

Lors de l'installation de l'appareil d'air conditionné sur le toit, il faudra protéger la partie supérieure de la cabine avec un linge ou une couverture de protection afin d'éviter les éventuelles égratignures.

Durant l'installation du **Compact**, tenir compte du fait que normalement les cabines pourvues d'écouille possède une structure suffisamment solide pour supporter le poids de l'appareil. Cependant, si ce n'est pas le cas et qu'il est nécessaire de découper le toit ou même si disposant d'écouille, la structure n'est pas suffisamment rigide (si elle était en fibre, plastique, etc.) il appartiendra à l'installateur de décider s'il faut renforcer le toit pour éviter toute déformation, rupture ou voie d'eau, etc., et prendre les mesures nécessaires à cet effet.

Outils

Jeu de clés Torx

Jeu de clés Allen

Clé fixe 10, 13, 14

Ciseaux

Mètre

Symbologie



Fragile



Attention aux coupures !



Risque électrique



Garantie



L'installateur devra posséder la formation pertinente en air conditionné sur véhicules.



dirna Bergstrom, s.l., ne sera pas responsable des dommages ou des bris dérivés d'une installation ou d'une manipulation incorrecte ni des modifications réalisées sans autorisation expresse par écrit.



Appareil pré-chargé de gaz réfrigérant. (Ne pas manipuler le circuit de gaz réfrigérant).



Voir la **procédure de garantie** du produit au **Diagnostic de problèmes**.



Voir le **Guide de l'Usager** de l'appareil pour le fonctionnement correcte de la télécommande et du tableau de commande.



Après l'installation, vous devez fournir à l'utilisateur: Manuel d'utilisation, garantie et diagnostic de pannes.

 Avant de commencer le montage, monter la grille d'entrée d'air frontale.



1 Démontez le couvercle de l'écouille ainsi que les éléments de fixation et remettre au client (*).

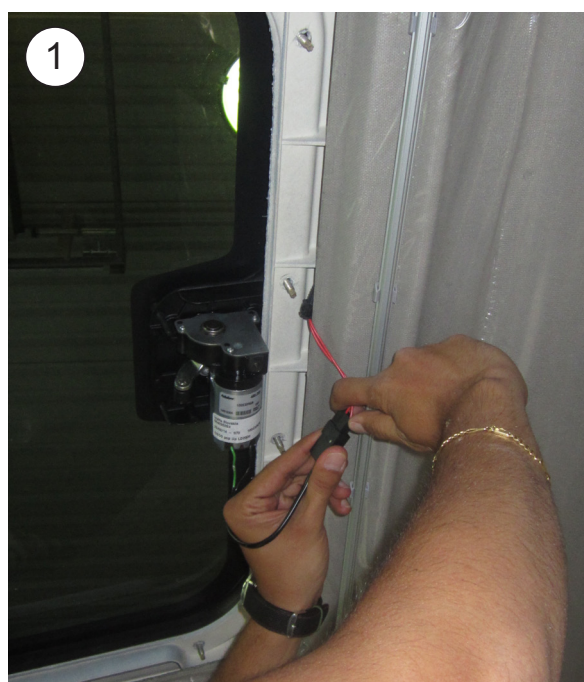
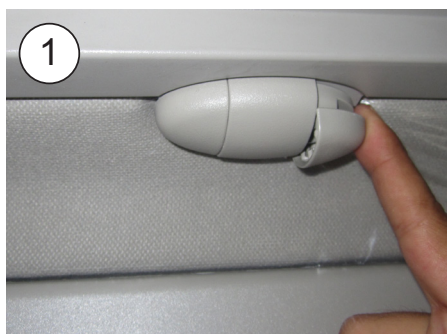

2 Eliminer les restes d'adhésif de la surface supérieure de la cabine avant de coller le joint EPDM.

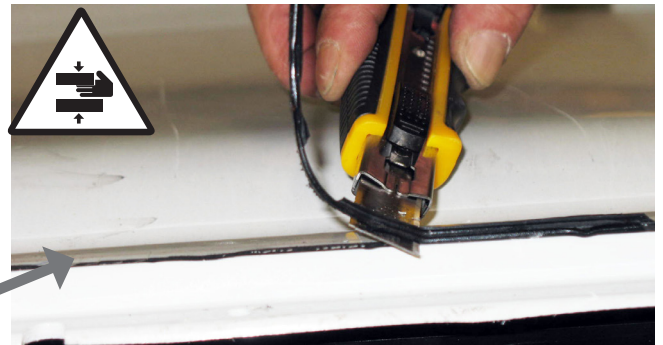

2a Coller le joint EPDM autour de l'orifice de l'écoutille (voir détail pour découper les bords).



 **COMMENT COUPER LE JOINT EPDM POUR EVITER LES FILTRATIONS DANS LA CABINE**

A- Coller le joint en maintenant une protection en papier de 100 mm de chaque côté.

B- Retirer les deux morceaux de papier.

C- Coller en faisant pression sur les deux extrémités.

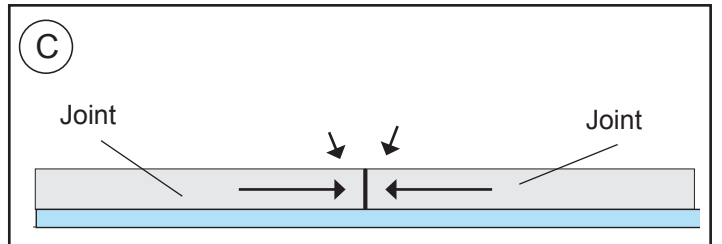
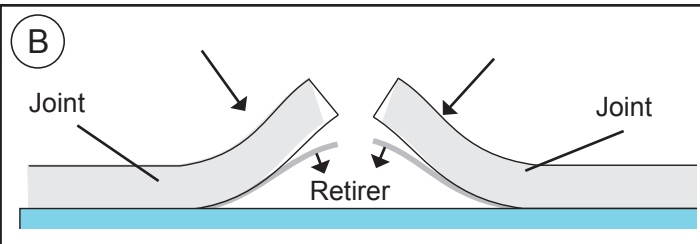
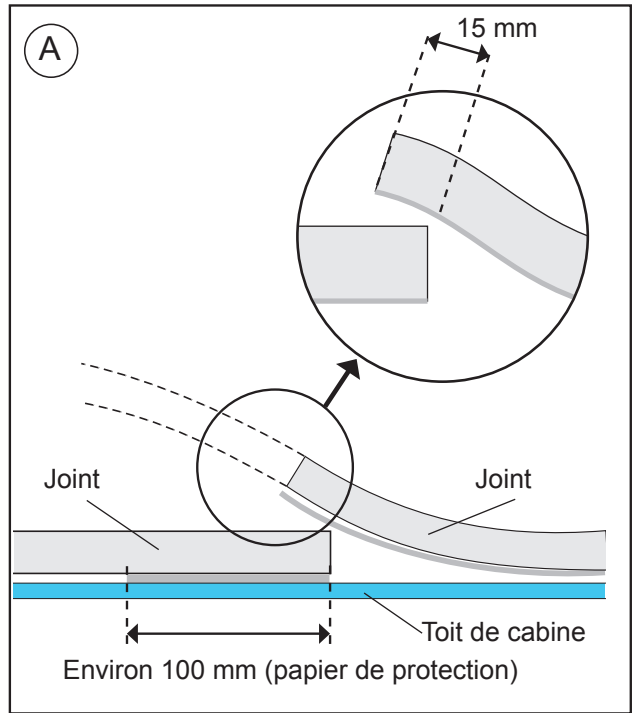

3 **EXTERIEUR CABINE:**
Positionner le Compact dans l'espace prévu.
Attention ! Avant de placer l'équipement sur le creux de l'écouille, vérifier que les sorties d'écoulement ne soient pas bouchées par le joint EPDM.

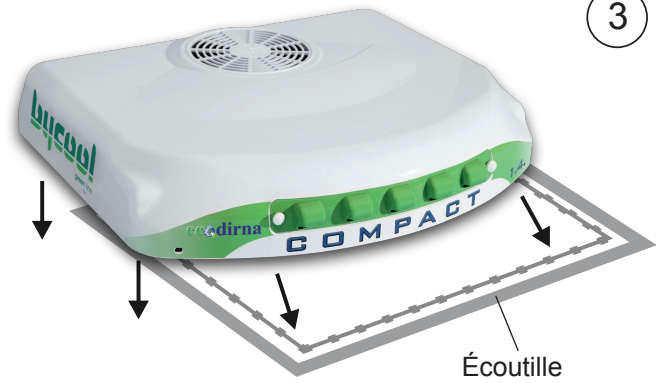

3

4 Position the foam rubber, ensuring the softest part is placed on the base of the unit.
Caution: Depending on the cabin, it may be necessary to use the (2) supplied ducts in order for the distribution panel to be completely adjusted.



4

5 **INTERIEUR CABINE:**
Visser 5 mm environ (4) goujons de 8/125x 100.

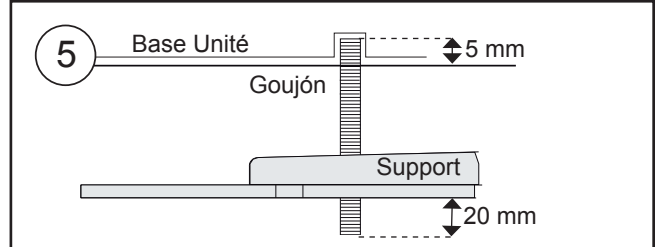

5

6 En suivant cet ordre :

- Rondelle a mouse.
- Rondelle plain diamètre 8 aile large.
- Écrou M8.
- Plain rondelle diamètre 8 aile large.

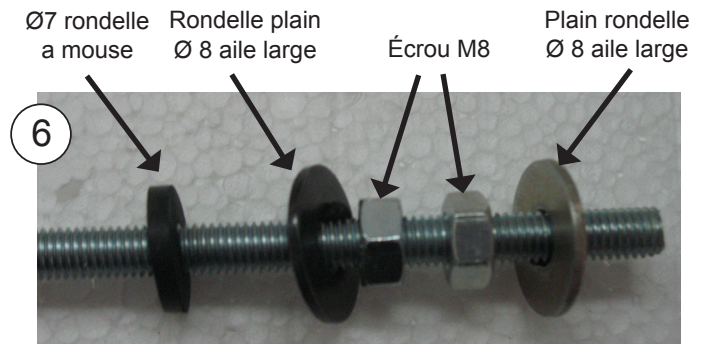

6

- 7** Placer les supports de fixation (2), avec une rondelle (1) et un écrou autobloquant (1) M8, sans serrer.

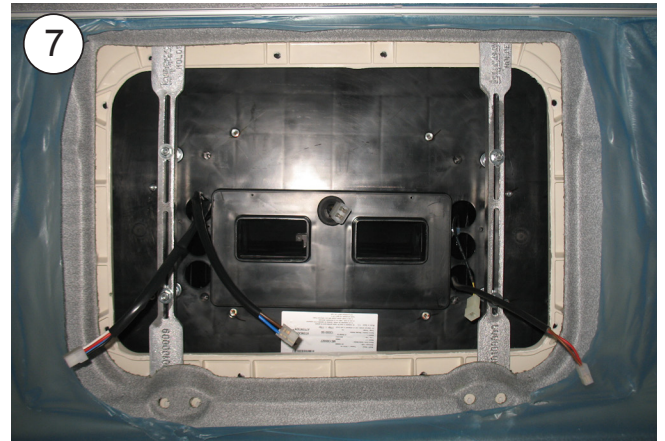

- 8** Visser 10 mm les goujons (4) M6 x 55 ou 80, comme indiqué au (D) du schéma point 17.

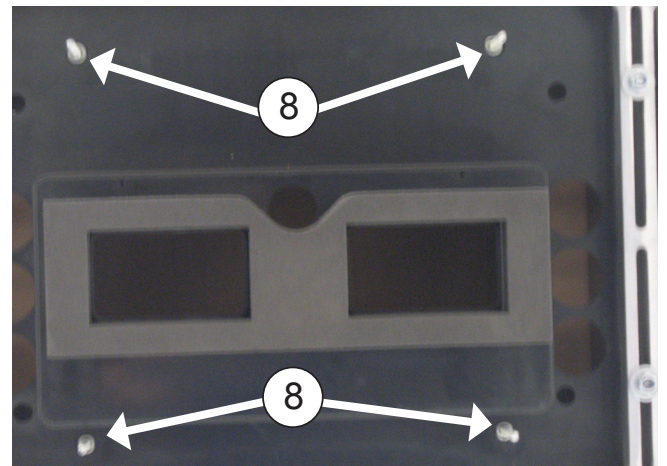
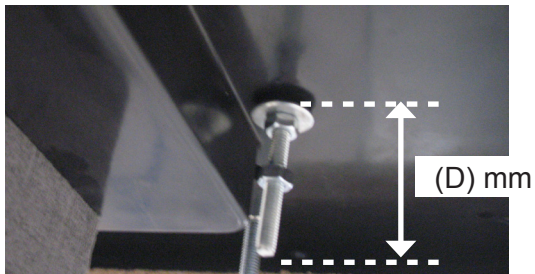

- 9** Placer (1) rondelle mousse diamètre 6 (1) plain rondelle diamètre 6 aile large et (1) écrou M6 sur chacun des asperges M6. En suivant serrer l'écrou jusqu'à la rondelle à mousse reste un peu pressée.

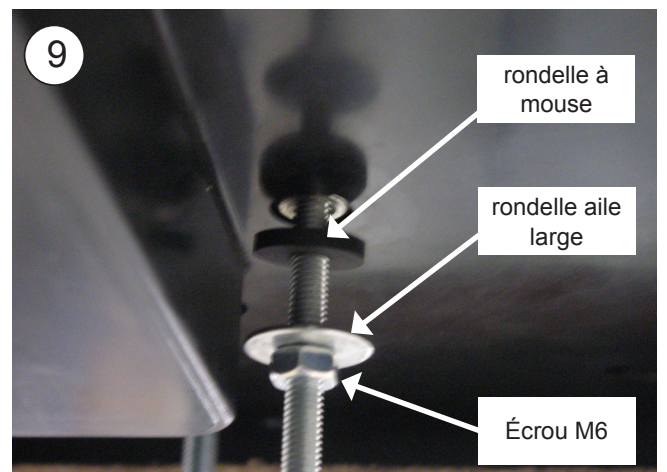

10 Placer l'écrou (1) M6 sans le serrer sur chaque goujon.

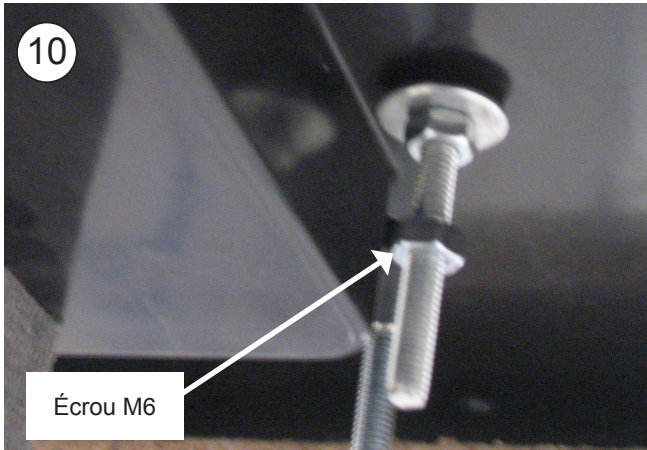
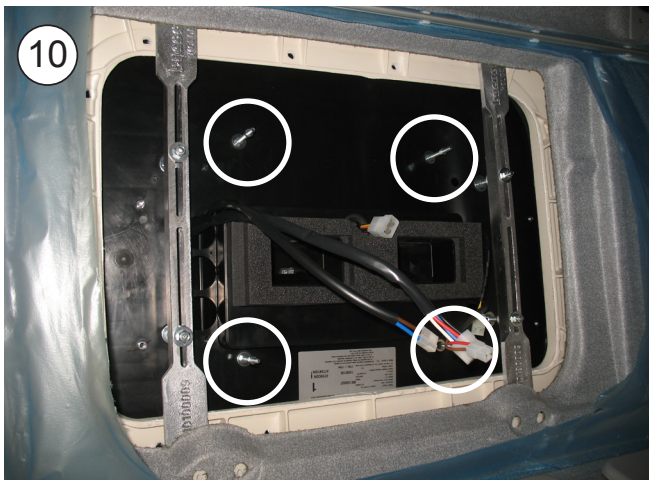

11 Connect the return air sensor 2-way box, the blower 4-way box and the electronic control cable connection 8-way box.

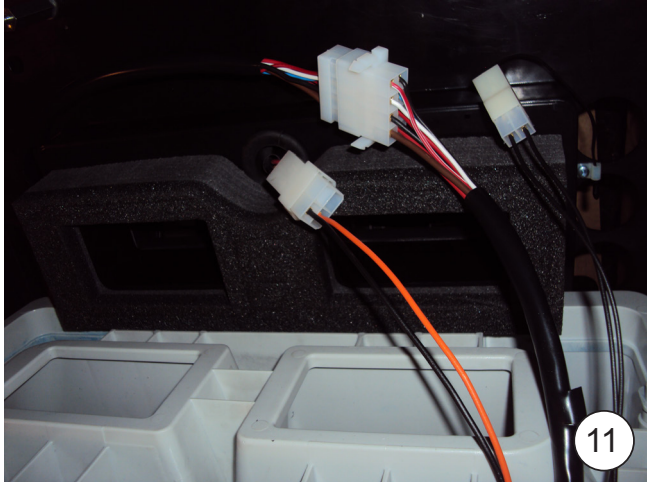

12

Placer le panneau intérieur de distribution d'air dans les goujons précédents avec (1) rondelle M6 surface large et (1) écrou M6 sur chaque goujon. Serrer les écrous jusqu'à ce que le canalisateur du panneau intérieur de distribution d'air heurte le caoutchouc mousse supérieur de l'équipement.

Important : les canaliseurs du panneau intérieur de distribution d'air doivent heurter le caoutchouc mousse supérieur de l'équipement pour éviter des fuites d'air.

Attention de ne pas coincer les câblages entre le canalisateur et le caoutchouc mousse placé dans la base de l'équipement.

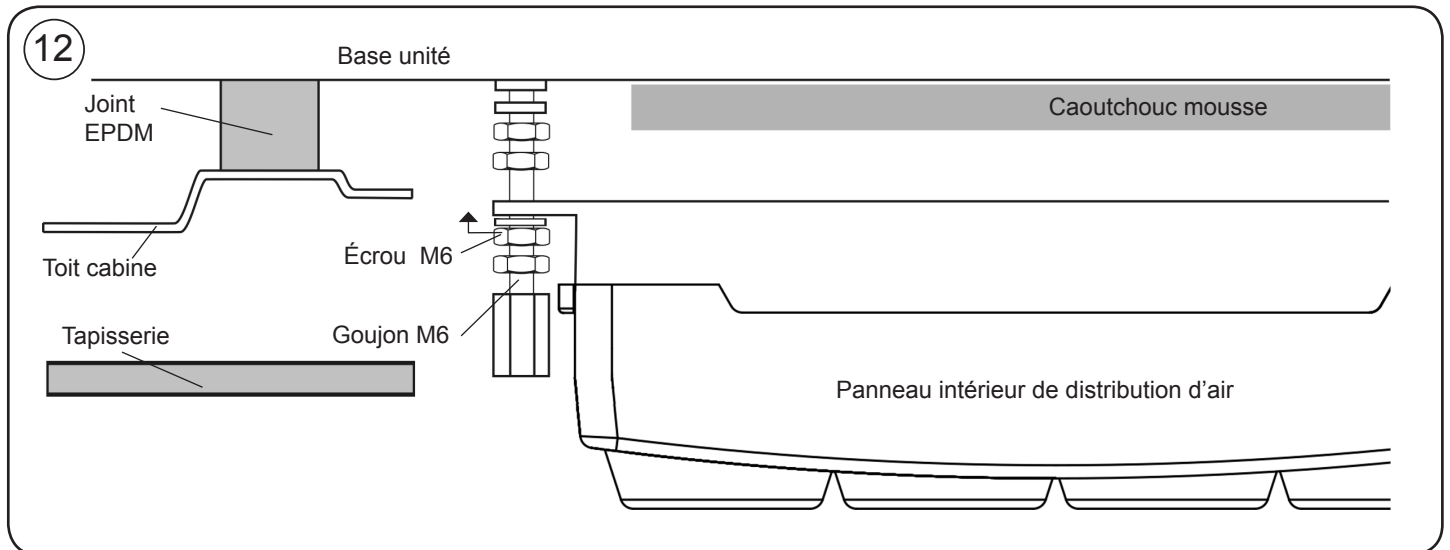

13

Apretar tuerca del punto 10 hasta hacer tope con la parte superior del panel interior de distribución de aire.

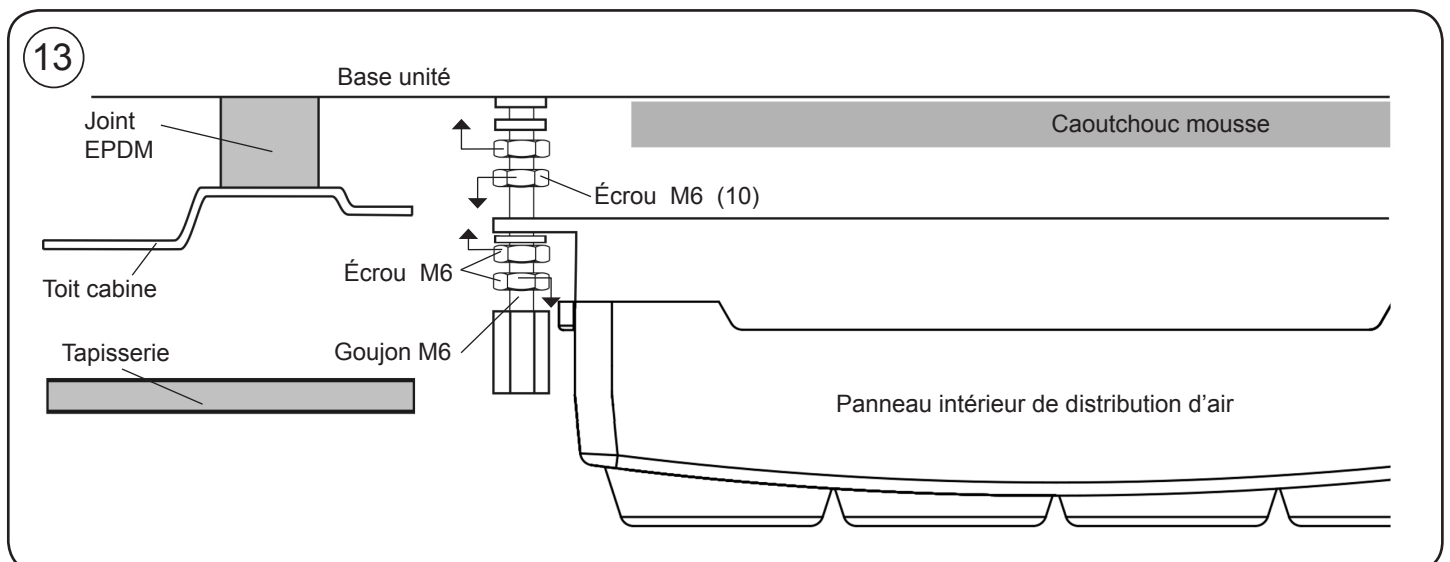

14 Placer la console et centrer l'appareil sur la partie convenant le mieux du toit de la cabine. Une fois centrée, retirer la console pour l'installer plus tard.



15 Fixer les supports en serrant les écrous jusqu'à serrer le joint EPDM de l'appareil entre 3 et 6 mm.

Important: Pour éviter la filtration d'eau dans la cabine, vérifier le serrage du joint EPDM à la base du Compact, comme indiqué sur le diagramme.

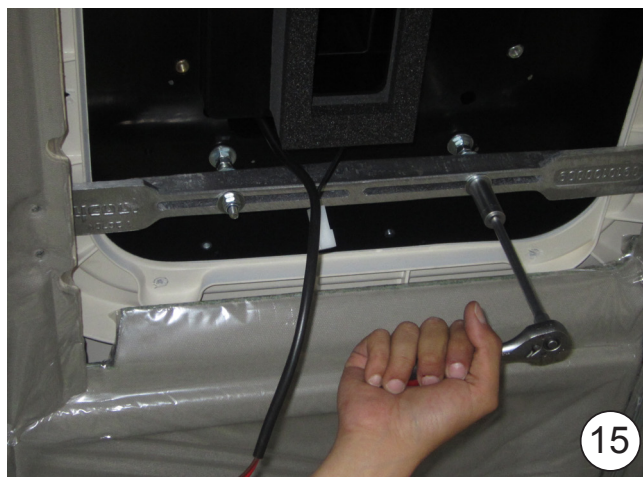
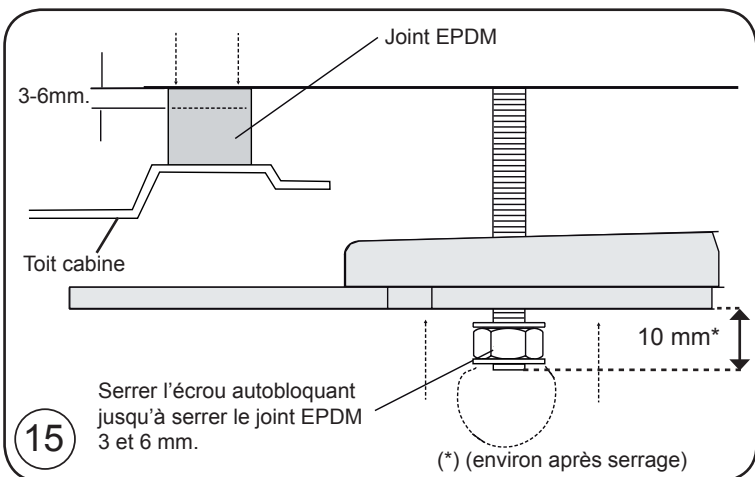

16

Serrer les écrous (4) M 8 afin de fixer à (4) l'unité base.



17

Placer un écrou M6 (A) après l'écrou de fixation du panneau intérieur de distribution d'air dans chaque goujon. Placer les hexagones M6 en vissant jusqu'à ce qu'il reste 1 mm au-dessus de la tapisserie. Dévisser les écrous M6 (A) de ce point jusqu'à atteindre les hexagones et serrer contre eux.

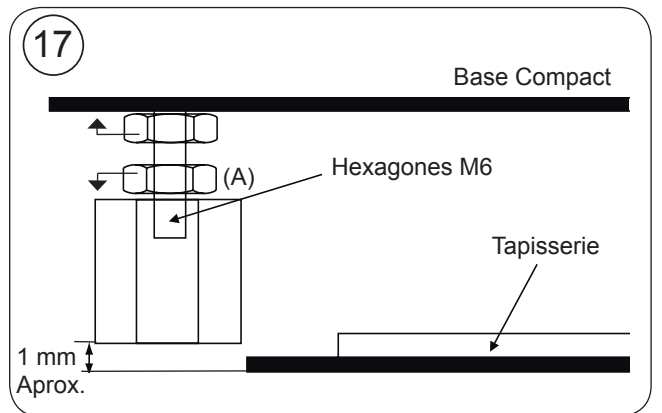

17

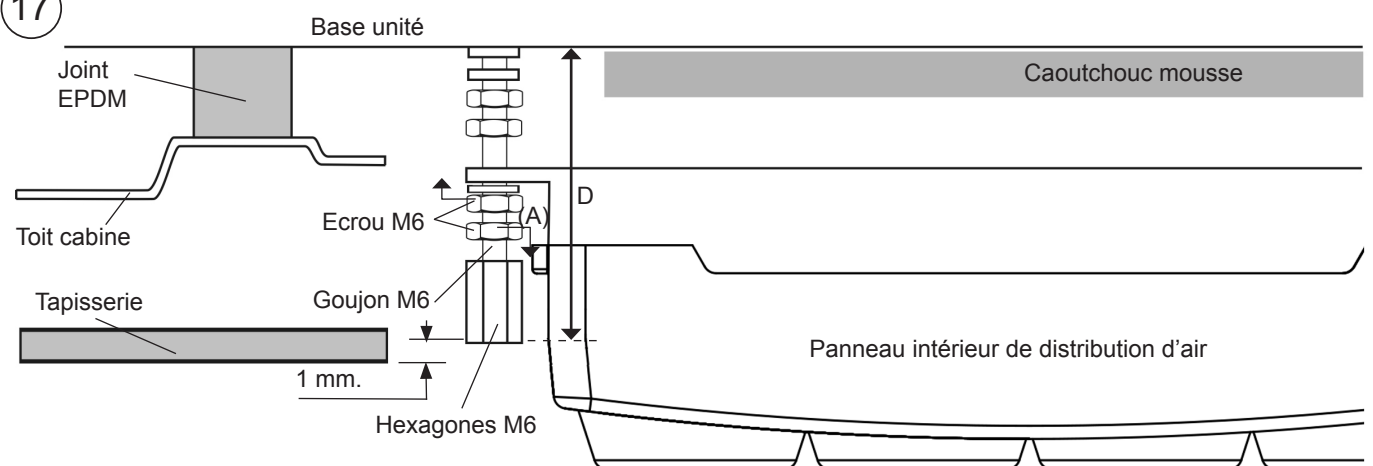

18 Placer la console à l'aide des (4) vis Allen M6/100x15.



19 Couvrir les têtes des vis Allen (4) M6/100x15 avec les capuchons en plastique M6.

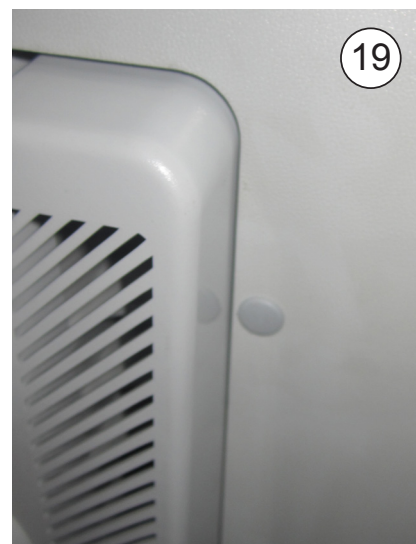

20

Visser (4) vis 6/100x15 à l'enjoliveur de la console d'origine et cacher ces dernières avec un bouchon à écrous.



Vue explosée jusqu'à la fixation des supports de fixation

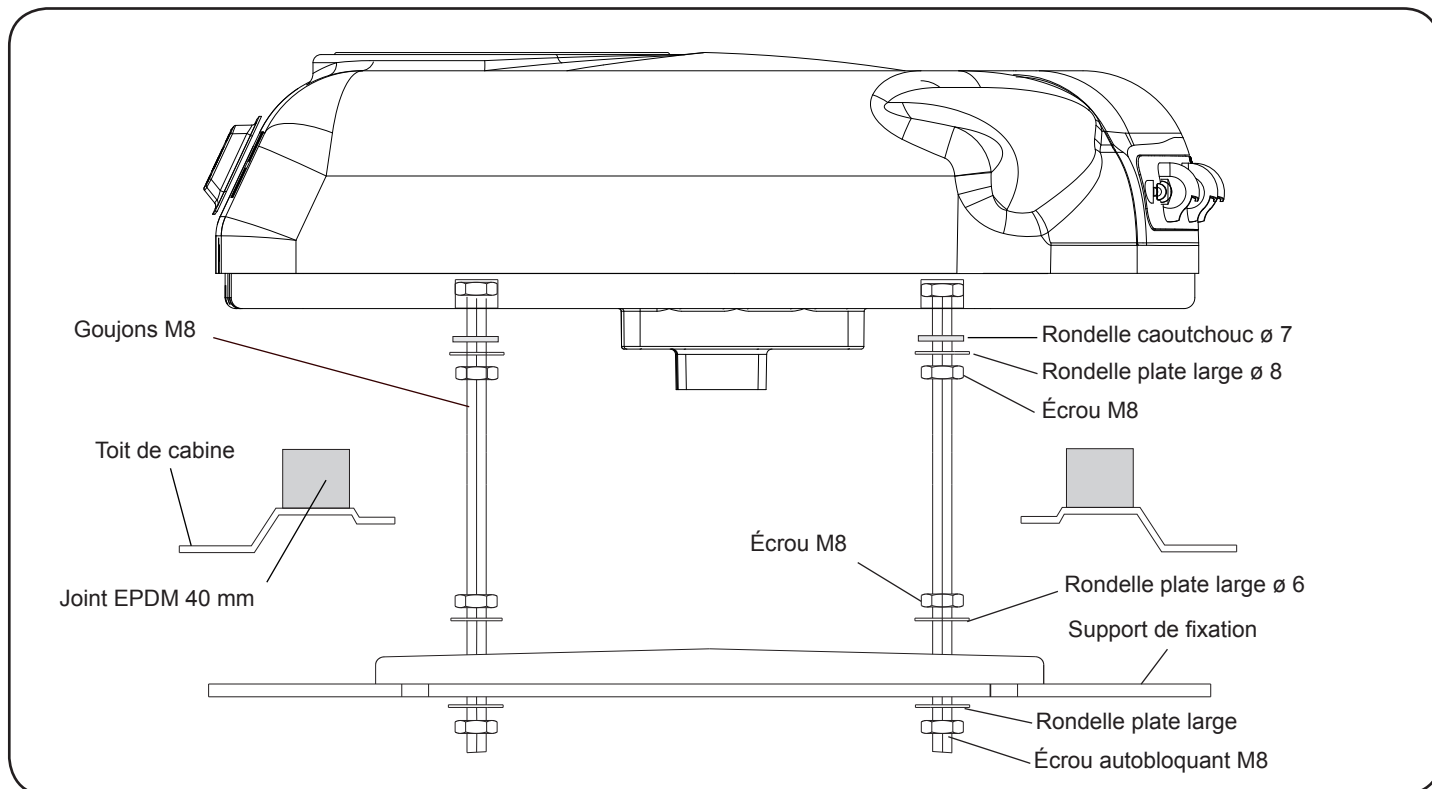

Vue explosée jusqu'à fixation des consoles

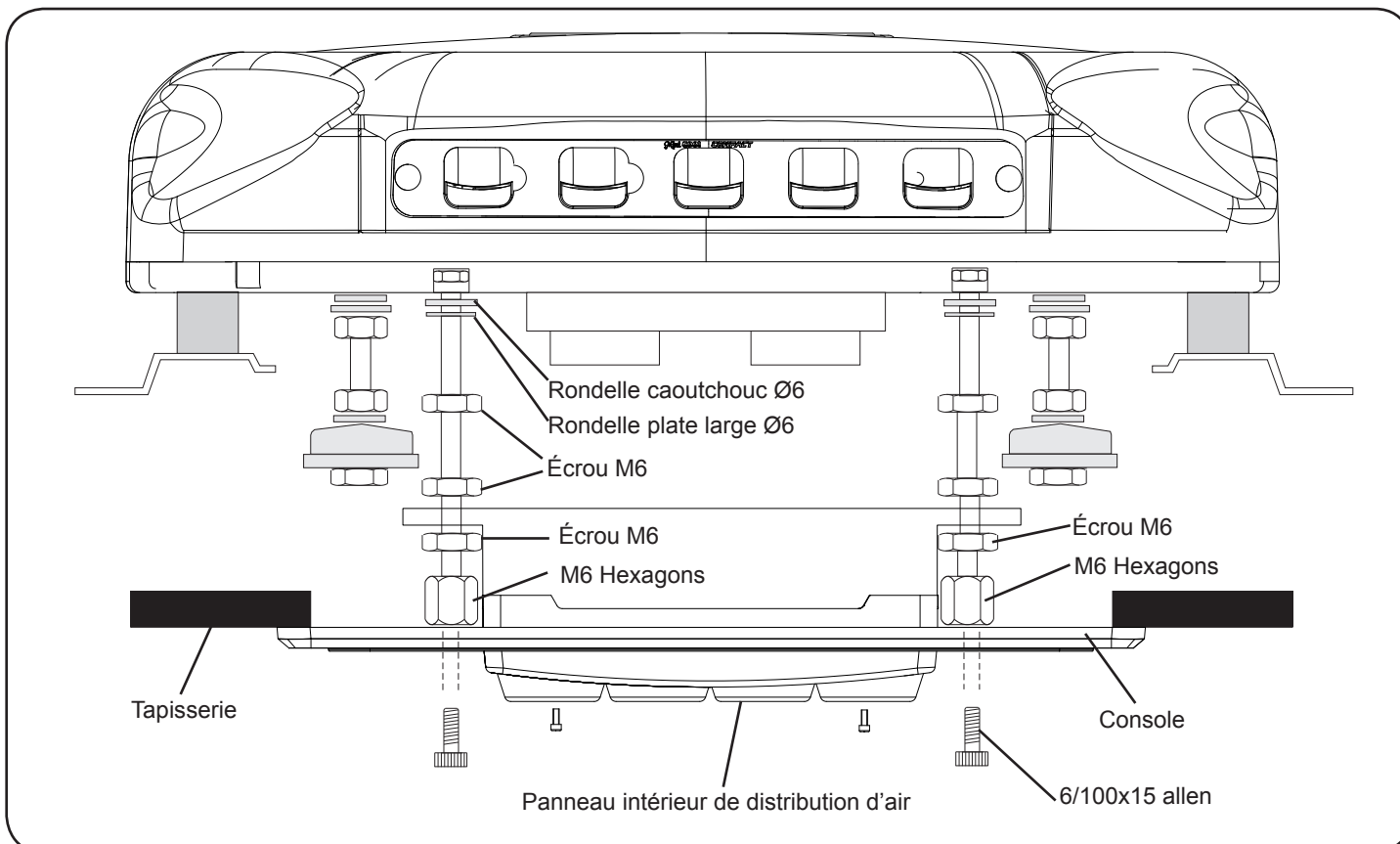

Instructions détaillées sur l'installation du câblage d'alimentation

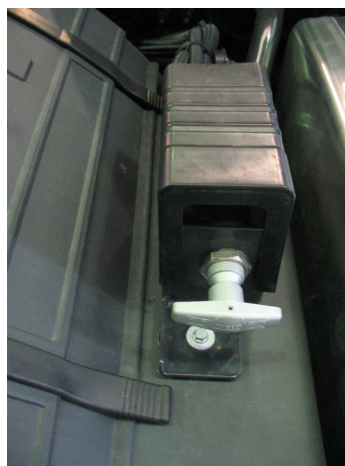
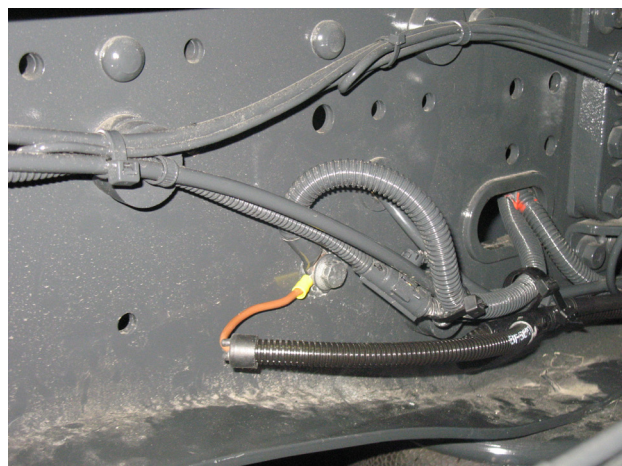
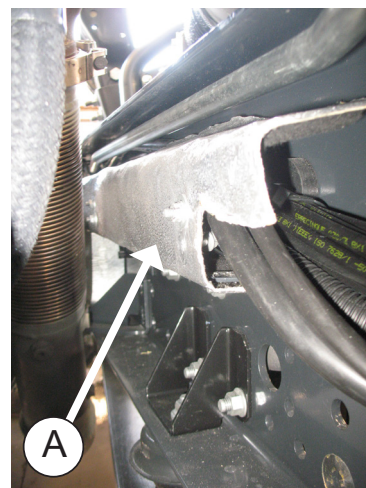

- 1 Llevar el cable de alimentación del equipo hasta corta corriente (positivo) y punto de masas (negativo) del vehículo, pegando los soportes de plástico en la parte posterior de la cabina y fijandolo con bridas; después con la cabina abatida pasar el cable por la parte inferior de la misma sujetándolo con abrazaderas y tornillos M4; y hasta la batería con bridas; se debe utilizar el mismo paso del cableado original (por dentro de la protección del tubo de escape (A)). (*Para pegar los soportes de plástico limpiar bien la zona antes*). Al conectar el equipo a la batería éste hará un test en todos sus leds, aparecerá en el display **88-bd** y se apagará.



IMPORTANT : consultez la notice avant la mise en marche.

Câblage électrique

AVERTISSEMENT IMPORTANT!

Précaution: ne pas inverser les polarités lors du branchement de l'appareil. Dans ce cas, la plaque de commandes ne s'allume pas et l'appareil ne fonctionne pas.

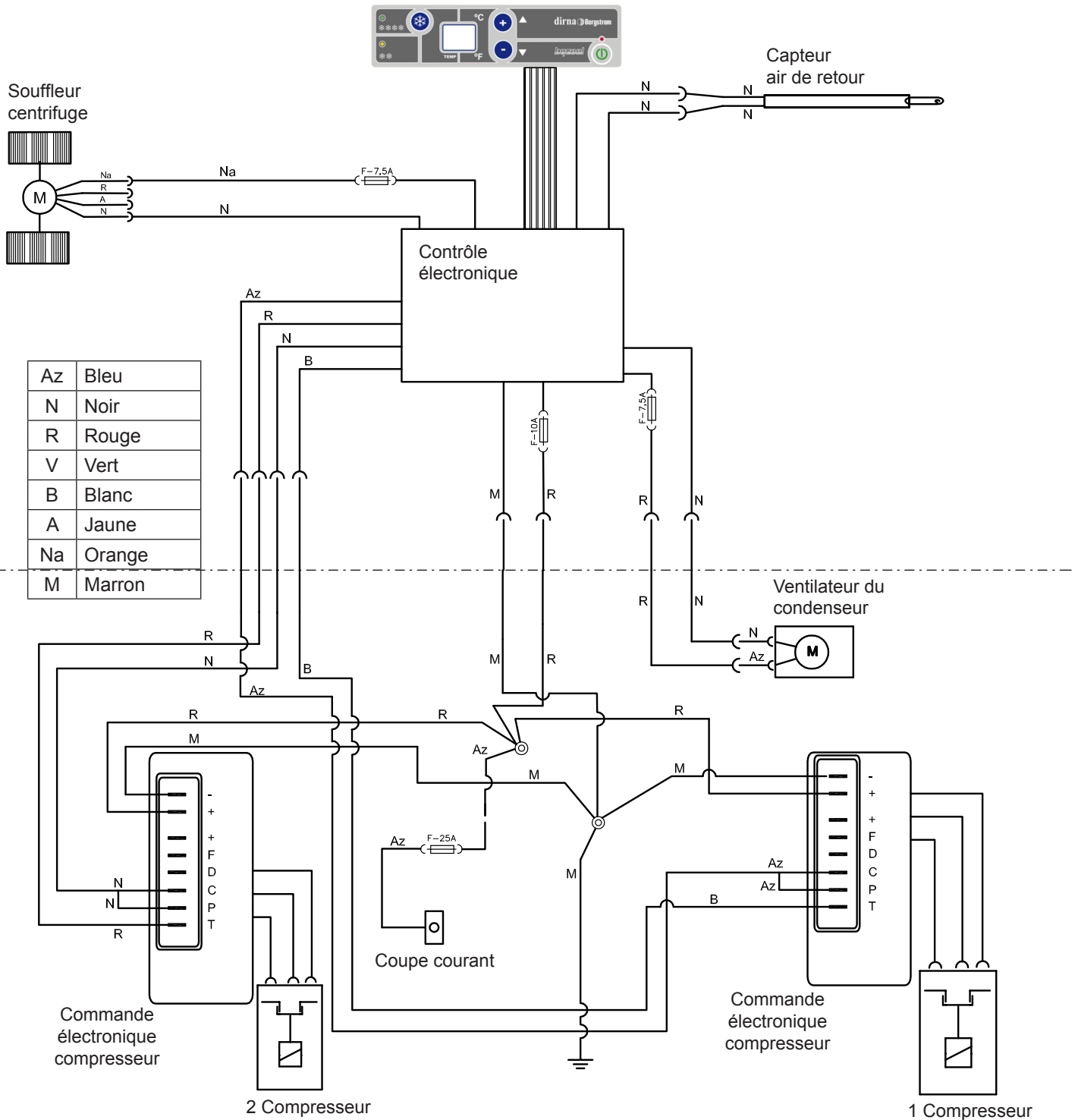

**Empfehlungen
Zur montage**

- Vor und während der Montage bitte diese Anweisungen lesen und beachten.
- Benutzen Sie für jeden Arbeitsschritt die geeigneten Werkzeuge.

Elektrizität

- Zündschlüssel abziehen.
- Vor Montagebeginn die Batterie abklemmen.
- Den ordnungsgemäßen Anschluss und die korrekte Installation der Elektrokomponenten überprüfen.

 **Achtung**

Sollte sich das Gerät während der Montage neigen, muss man mindestens 60 Minuten warten, nachdem es wieder in die horizontale Lage gebracht wurde, um es wieder einzuschalten.

Mitgelieferte unterlagen

Montageanweisungen	1001207468
Benutzerleitfaden	220AA60170
Fehlerdiagnose	220AA60013
Garantie	220AA10017



 **Achtung**

Wird die Klimaanlage im Kabinendach installiert, muss der obere Teil der Kabine mit einem Tuch oder einer Decke gegen eventuelle Kratzer geschützt werden. Bei der Installation der **Compact** auf dem Kabinendach muss darauf geachtet werden, dass mit Luken ausgestattete Kabinen über eine ausreichend stabile Struktur verfügen, um das Gewicht des Geräts stand zu halten. Sollte das Fahrzeug über keine Luke verfügen und sollte es notwendig sein, das Kabinendach aufzuschneiden, bzw. sollte die vorhandene Struktur nicht ausreichend stabil sein (z.B. wenn sie aus Faser, Kunststoff usw. hergestellt ist), obliegt es dem Installateur zu entscheiden, ob das Kabinendach zur Vermeidung von Verformungen, Brüchen, undichten Stellen usw. verstärkt werden muss, und die hierfür notwendigen Mittel bereit zu stellen.

Werkzeuge

- Torx-Schraubenschlüssel
- Inbusschraubenschlüssel
- 10er, 13er, 14er Schraubenschlüssel
- Schere
- Metermaß

Symbologie

-  Fragile
-  Attention aux coupures !
-  Risque électrique

 **Warnhinweise**

-  Der Installateur muss im Bereich Fahrzeug-Klimaanlagen ausreichend geschult sein.
-  **dirna Bergstrom, s.l.** übernimmt keine Verantwortung für Schäden oder Brüche aufgrund einer nicht ordnungsgemäßen Installation oder Bedienung des Geräts oder den Austausch von Teilen bzw. Umbauten, die ohne die erforderliche schriftliche Genehmigung durchgeführt wurden.
-  **Mit Kältemittel vorgefülltes Gerät. (Kältemittelkreislauf nicht manipulieren).**
-  Siehe **Garantieverfahren** des Produkts in der **Fehlerdiagnose**.
-  Siehe **Benutzerleitfaden** des Geräts für den ordnungsgemäßen Betrieb der Fernbedienung und des Bedienfelds.
-  Die folgenden Unterlagen müssen dem Benutzer nach der Installation ausgehändigt werden: **Benutzerleitfaden, Garantie und Fehlerdiagnose.**

 Vor Montabeginn vorderes Lufteintrittsgitter montieren.



1 Lukendeckel abnehmen, Befestigungsteile entfernen und dem Kunden übergeben (*).

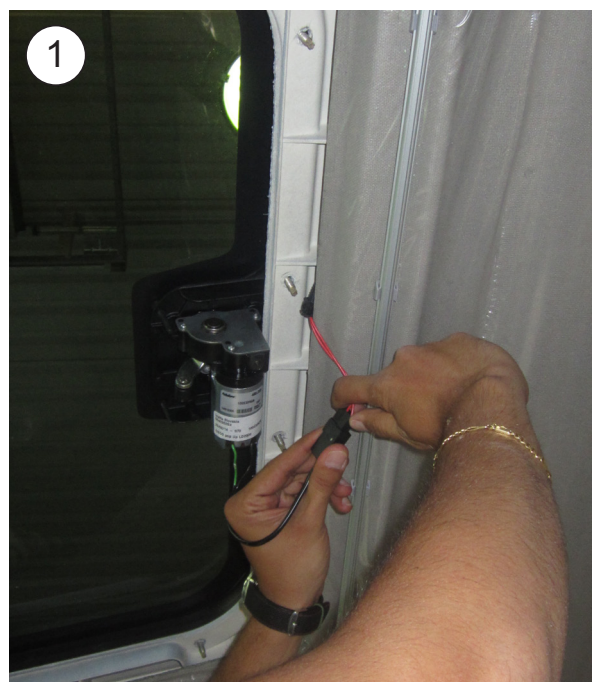

2

Falls der Spoiler eine Mittelstange hat, diese im Bereich der Punkte schneiden, um das Gerät installieren zu können.

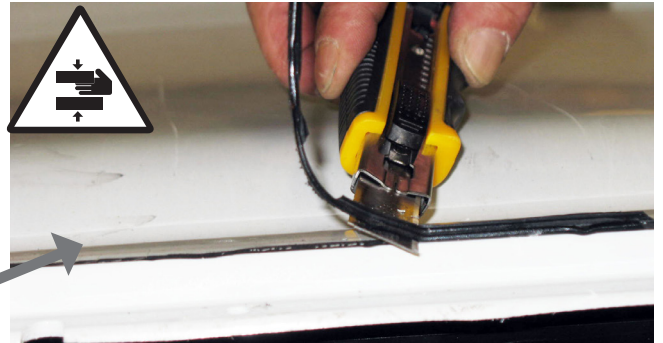

2a

Die EPDM-Dichtung um die Lukenöffnung herum ankleben (siehe Detailansicht für das Schneiden der Ränder).



WIE DIE EPDM-DICHTUNG GESCHNITTEN WIRD, UM FILTRATIONEN IN DER KABINE ZU VERMEIDEN

A- Dichtung aufkleben und dabei einen Papierschutz von 100 mm auf jeder Seite beibehalten.

B- Die zwei Papierstücke entfernen.

C- Unter Anpressen beider Enden aufkleben.

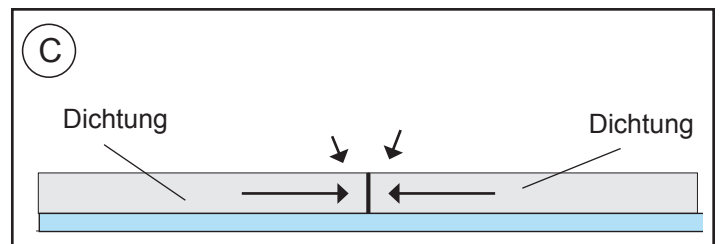
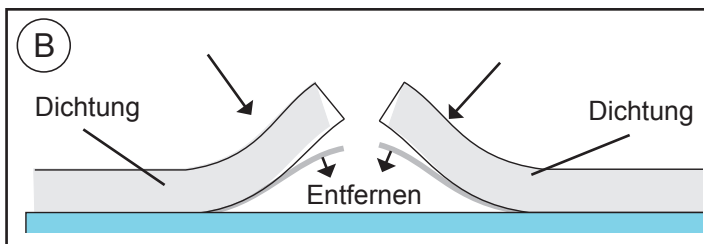
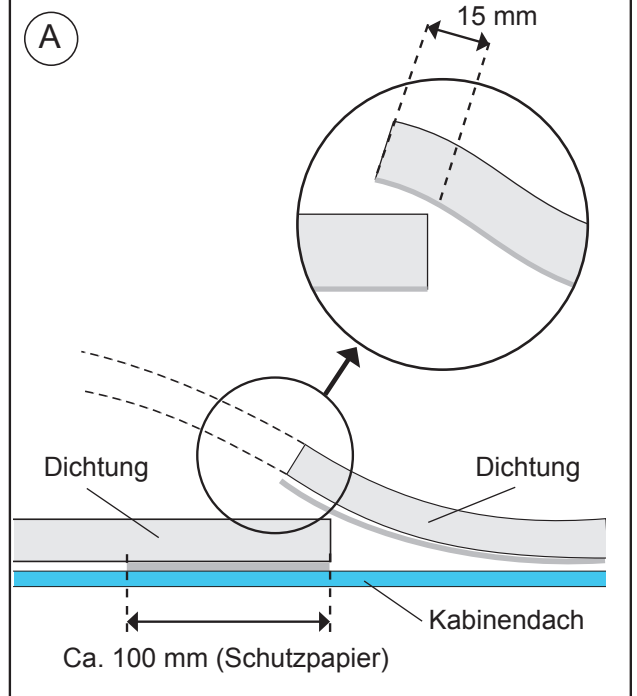

3 **KABINENAUSSENSEITE:**
Compact in der Öffnung positionieren.
Achtung! Beim Auflegen des Geräts auf die Lukenaussparung darauf achten, dass die Ablassausgänge nicht von der EPDM-Dichtung zusammengedrückt werden.

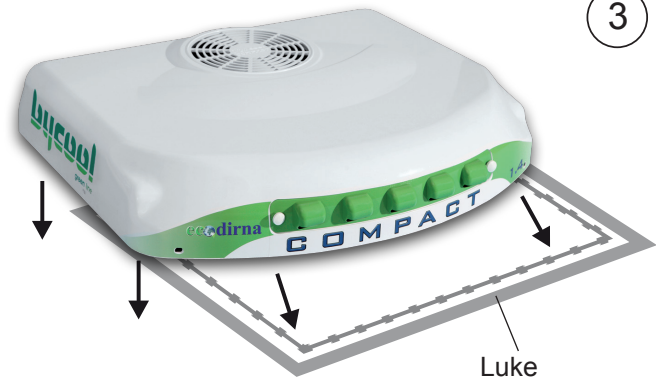
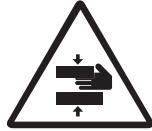

4 Schaumgummidurchführung anbringen, wobei der weichere Teil auf der Gerätegrundplatte aufliegt.
Achtung: Je nach Kabine kann es erforderlich sein, die (2) mitgelieferten Führungen zu verwenden, damit die Luftverteiltertafel ordnungsgemäß ausgerichtet ist.



5 **KABINENINNENSEITE:**
 Ca. 5 mm Gewinde für (4) Stiftschrauben 8/125x100.

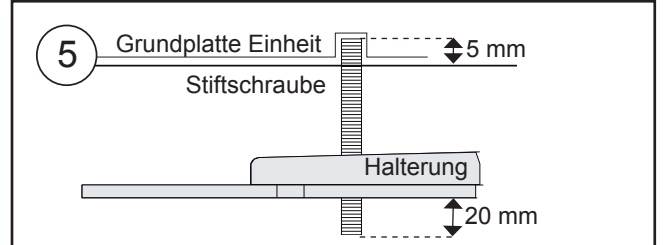

6 Montieren Sie wie folgt:
 • Gummischeibe.
 • 3D Unterlegscheibe.
 • Mutter.
 • Gewindestange.

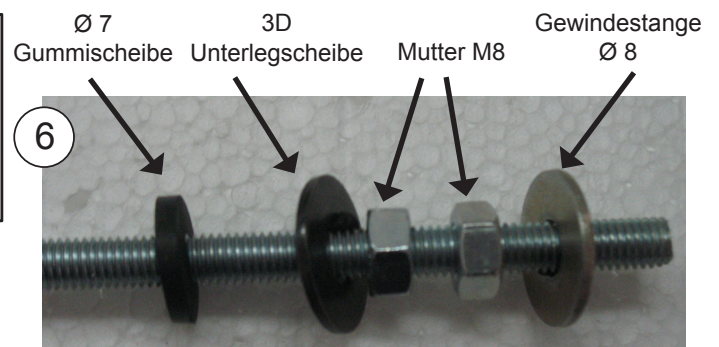

7 Befestigungsauflagen (2) mit einer Unterlegscheibe (1) und einer Autobloc-Mutter (1) M8 einlegen, **jedoch ohne anzuziehen**.



8 10 mm Gewinde für die Stiftschrauben (4) M6 x 55-80 am angegebenen Punkt schneiden laut Distanz (D) beschrieben in Abbildung 17.

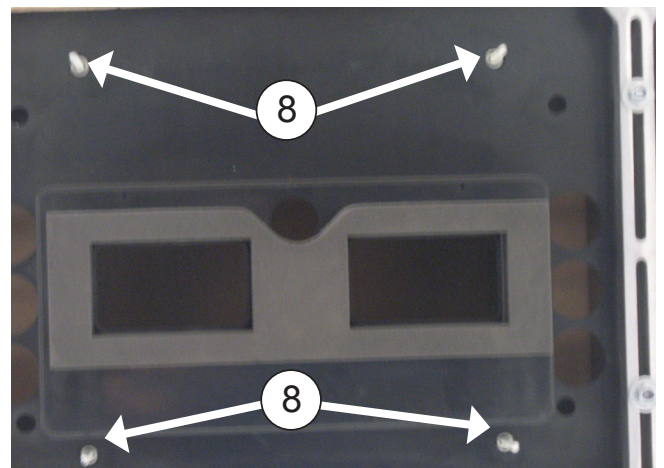
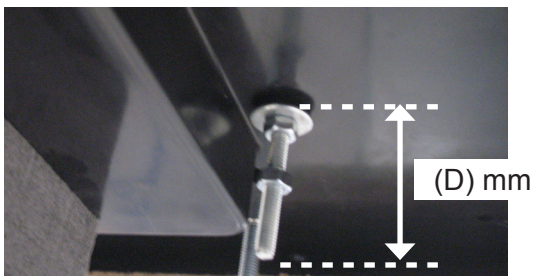

9 Montiere (1) Gummi-Unterlegscheibe, (1) 3D Unterlegscheibe (1) Mutter auf jede Gewindestange. Später ziehen Sie die Mutter an, bis die Gummischeibe ein wenig zusammengemisst ist.

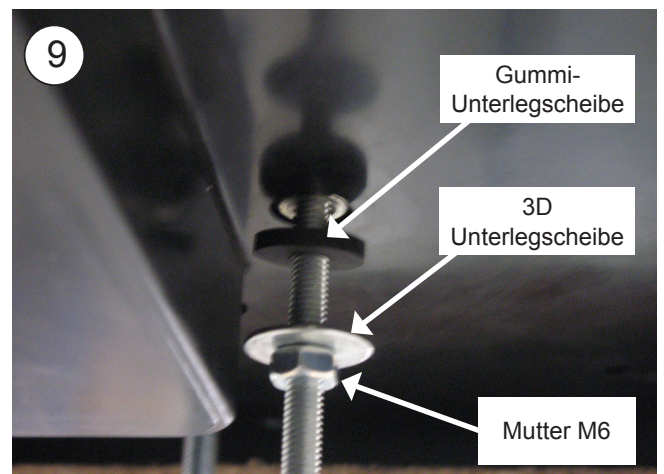

10 Jeweils die Mutter (1) M6 ohne Anziehen auf die Stiftschrauben legen.

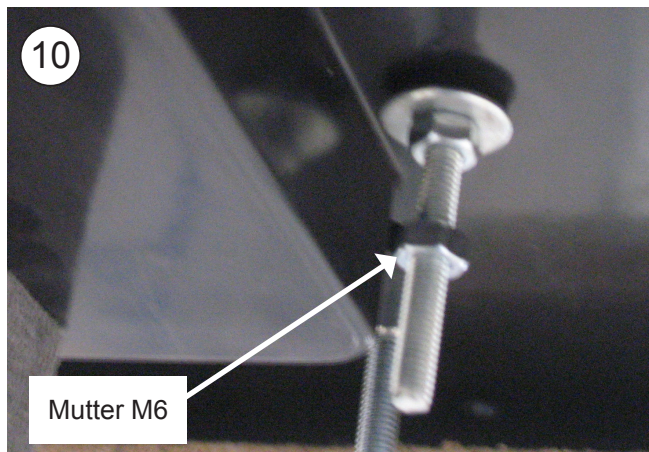
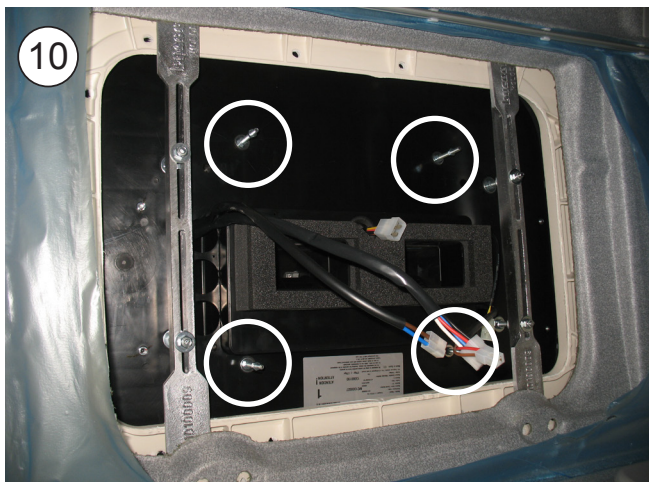

11 Den 2-Wege-Kasten des Abluftensors, den 4-Wege-Kasten des Gebläses und den 8-Wege-Kasten der Kabel der Elektroniksteuerung anschließen.

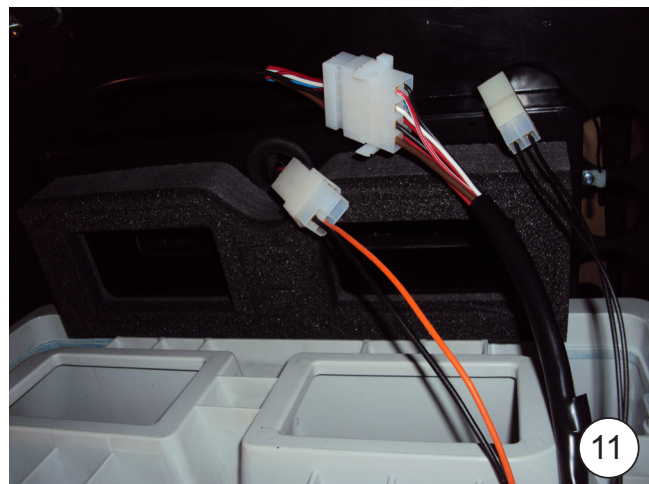

12 Innere Luftverteiltertafel an den vorgenannten Stiftschrauben mit jeweils (1) Breitflansch-Unterlegscheibe M6 und (1) Mutter M6 anbringen. Muttern anziehen, bis die Führung der inneren Luftverteiltertafel am oberen Schaumgummi der Anlage anschlägt.

Wichtiger Hinweis: Die Führung der inneren Luftverteiltertafel muss am oberen Schaumgummi der Anlage anschlagen, damit keine Luft austreten kann.

Darauf achten, dass die Kabel nicht zwischen Führung und Schaumgummi der Gerätegrundplatte eingeklemmt werden.

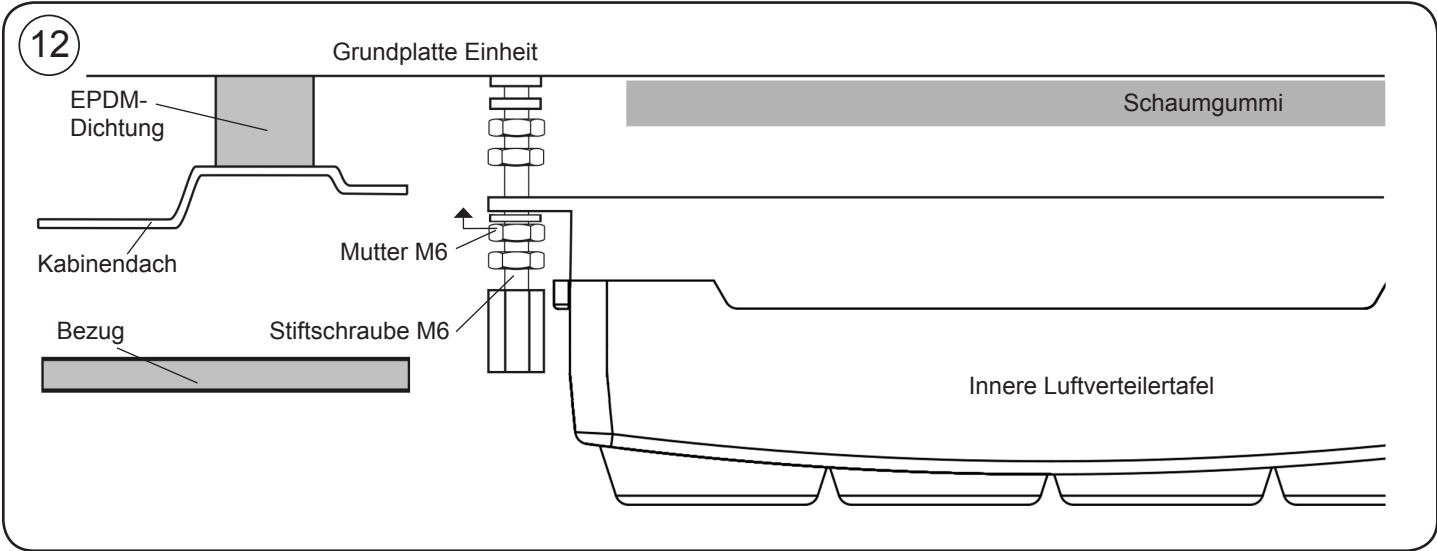

13 Mutter aus Punkt 10a anziehen, bis diese an das Oberteil der inneren Luftverteiltertafel stößt.

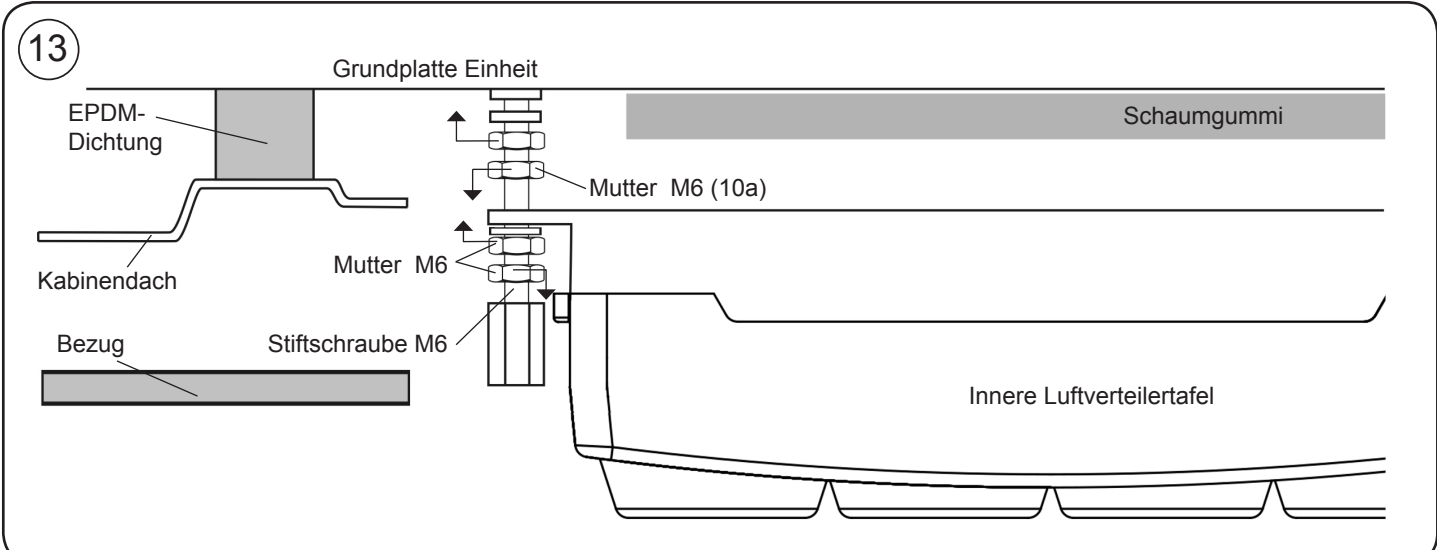

14

Die Konsole aufsetzen und das Gerät an der am besten geeigneten Stelle des Kabinendachs zentrieren. Nach der Zentrierung die Konsole für die nachfolgende Montage abnehmen.



15

Die Halterungen durch Anziehen der Muttern befestigen, bis die EPDM-Dichtung (Punkt 4) des Geräts zwischen 3 und 6 mm komprimiert wird.

Wichtiger Hinweis: Um das Eindringen von Wasser in die Kabine zu verhindern, die die Verbindung der EPDM-Dichtung mit der Grundplatte des Compact wie in Schema gezeigt überprüfen.

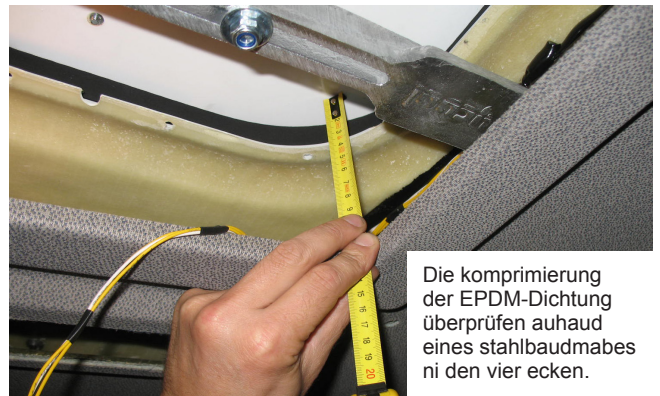

Die Komprimierung der EPDM-Dichtung überprüfen anhand eines Stahlbaudmaßes in den vier Ecken.

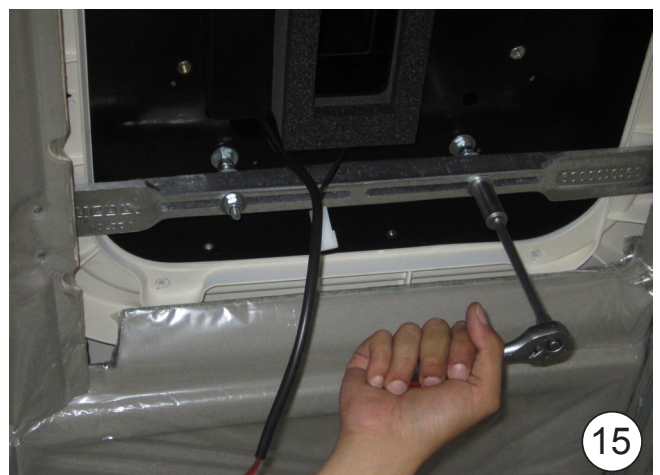
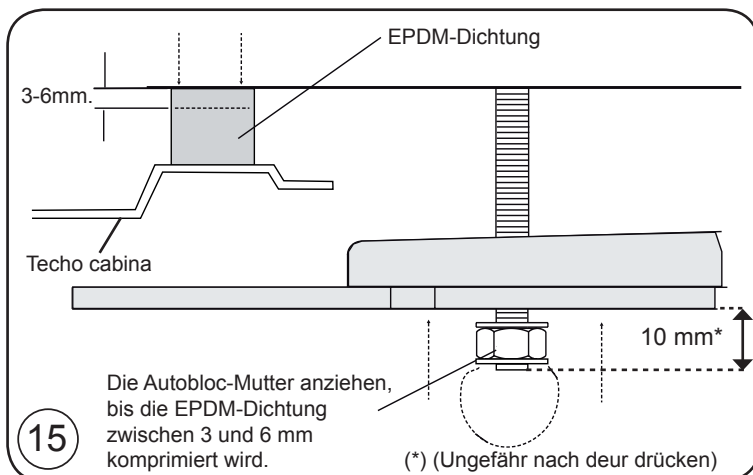

16 Die Muttern (4) M8 anziehen, um sie an der Grundplatte zu befestigen.



17 Eine Mutter M6 (A) hinter der Befestigungsmutter der inneren Luftverteiltertafel an allen Stiftschrauben anbringen. Sechskant-Verbindungs-muttern M6 eindrehen, bis sie 1 mm über dem Bezug herausstehen. Muttern M6 (A) dieses Punkts herausschrauben, bis sie an die Sechskant-Verbindungs-muttern anstoßen, und gegen diese anziehen.

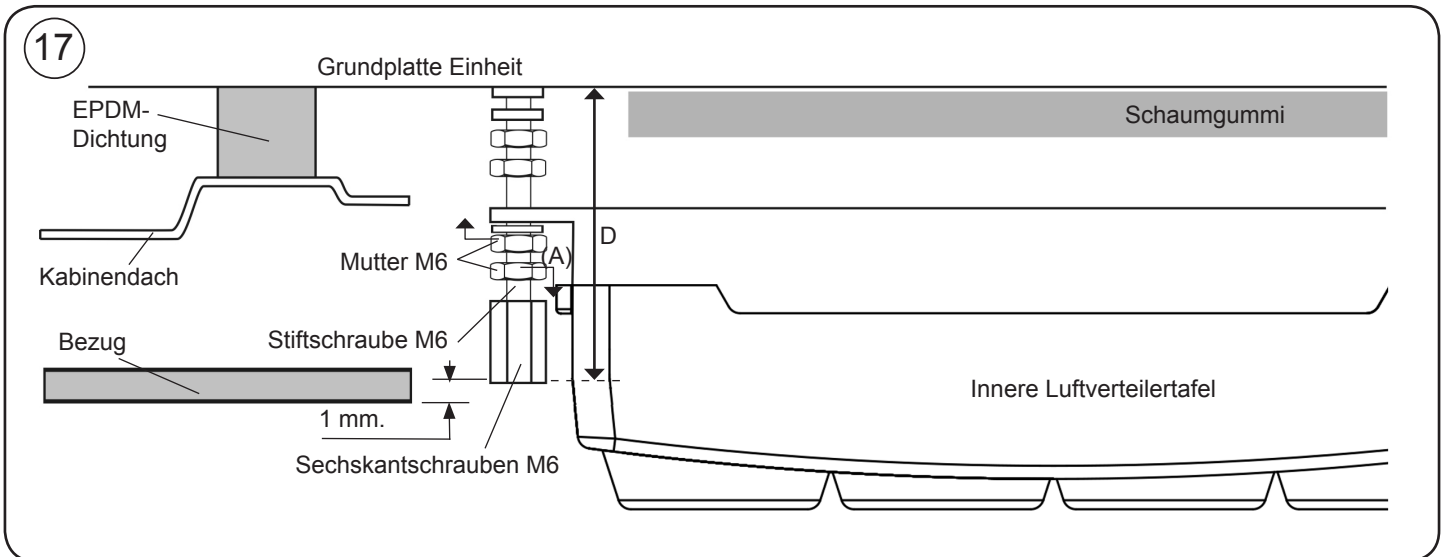
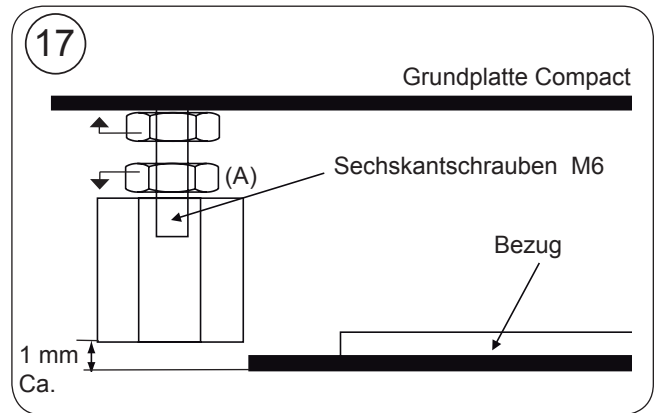

18 Die Konsole anhand von (4) Inbusschrauben M6/100x15 anbringen.

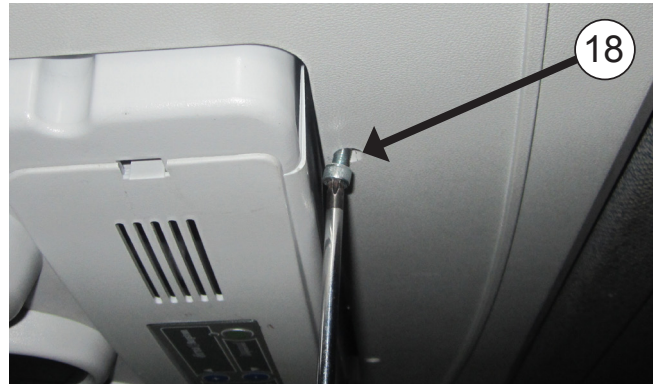

19 Die Köpfe der Inbusschrauben (4) M6/100x15 mit Kunststoffkappen M6 abdecken.

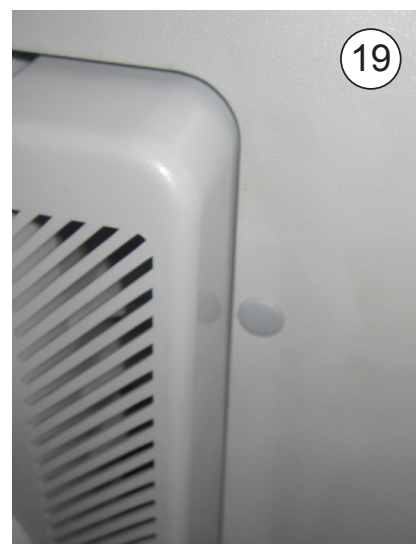

20

(4) Schrauben 6/100x15 in die Original-Zierleiste der Konsole drehen und mit Mutterkappen abdecken.



Explosionsansicht bis zur befestigung der befestigungsauflagen

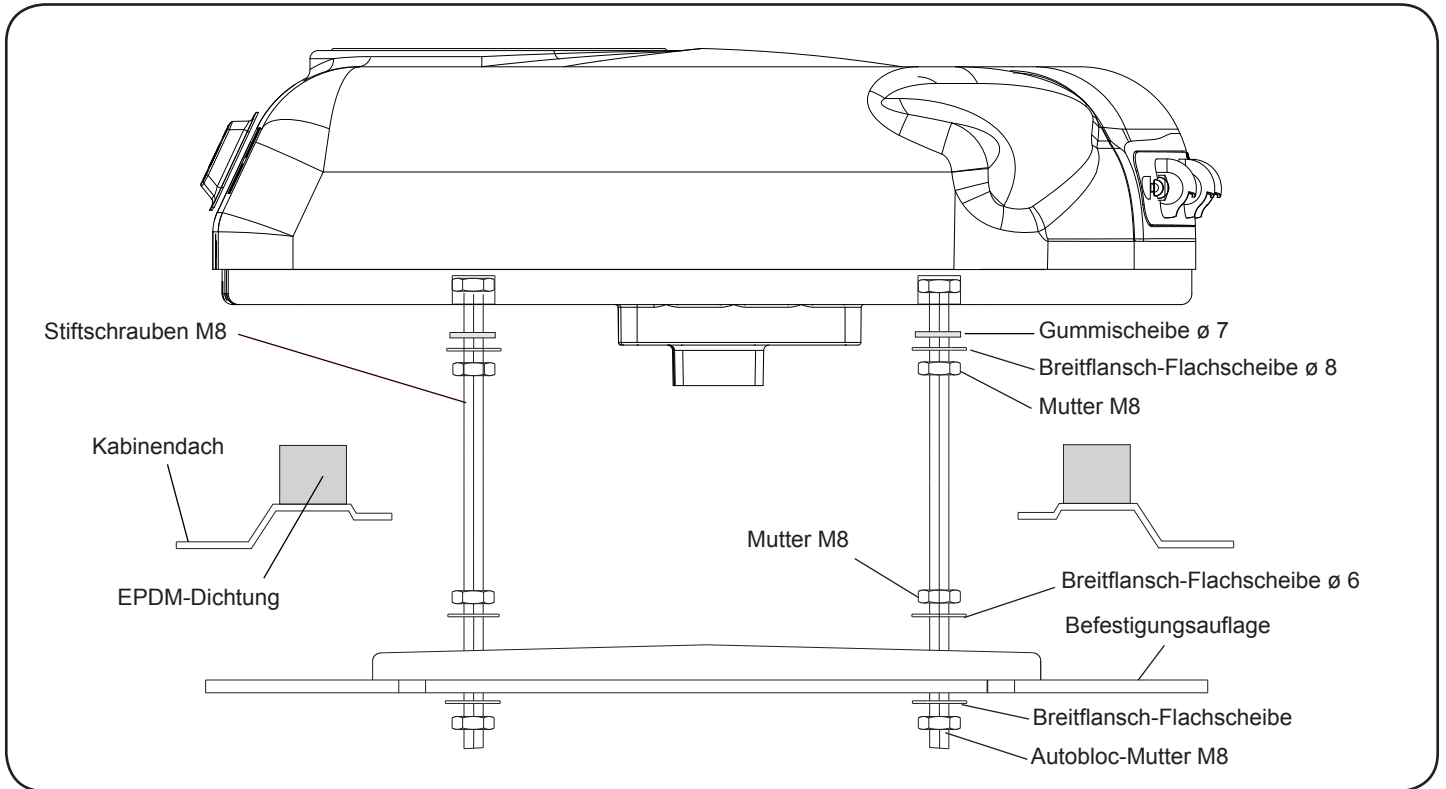

Explosionsansicht bis zur befestigung der konsolen

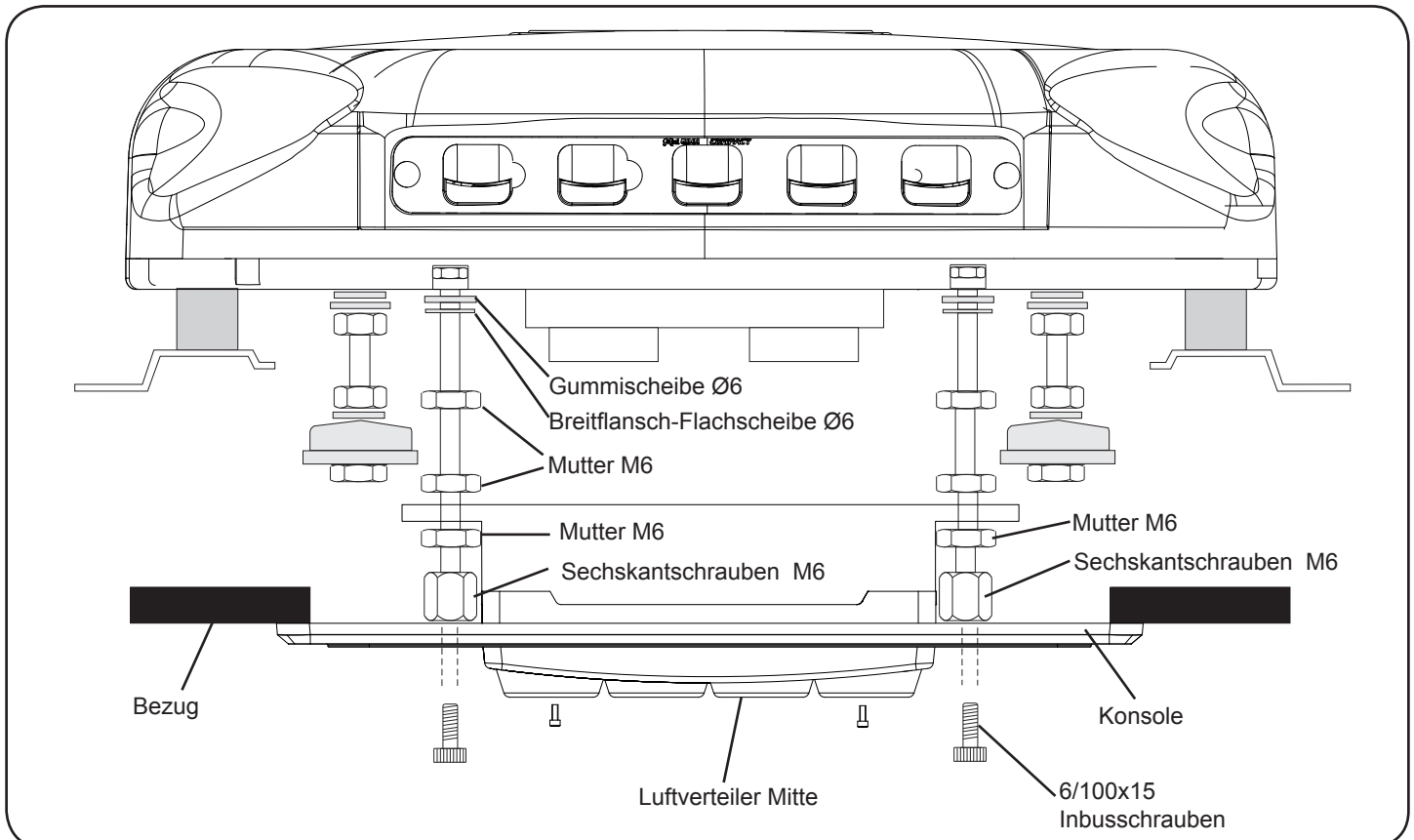

Ausführliche Einleitungen über die installation der Verkabelungsleitung

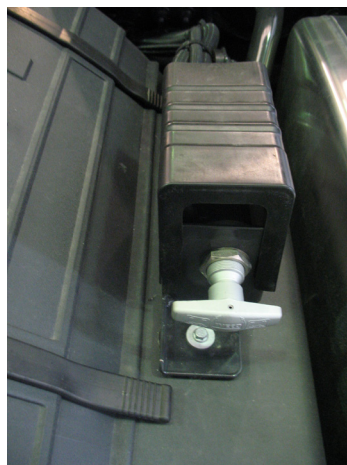
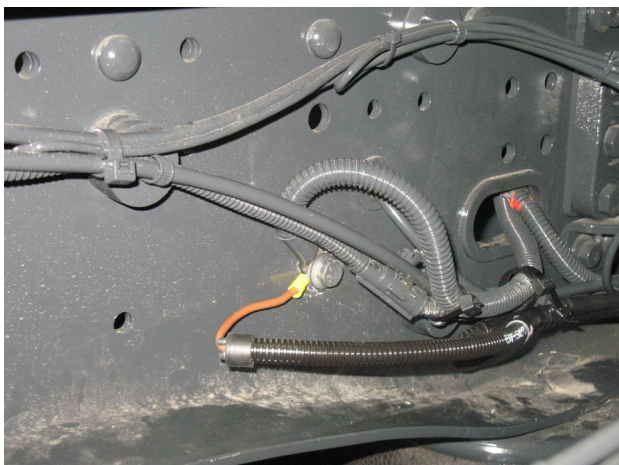
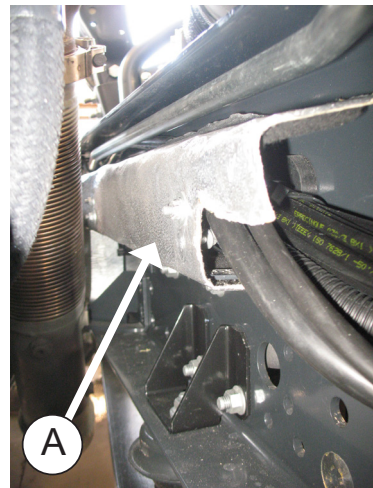

- 1 Netzkabel des Geräts zu Stromtrenner (*positiv*) und Massepunkt (*negativ*) des Fahrzeugs führen, Kunststoffhalterungen auf der Kabinenhinterseite aufkleben und mit Kabelbindern befestigen; danach das Kabel bei abgeklappter Kabine durch deren Unterseite führen und mit Schellen und Schrauben M4 befestigen bzw. bis zur Batterie mit Kabelbindern. Originalkabeldurchführung verwenden (*innerhalb des Auspuffrohrschatzes (A)*). (*Vor dem Ankleben der Kunststoffhalterungen den Bereich reinigen*). Beim Anschluss der Anlage an die Batterie führt die Anlage einen Test aller Leds durch; auf dem Display erscheint **88-bd** und sie schaltet sich aus.



WICHTIGER HINWEIS: Für die Inbetriebnahme sehen Sie bitte im Benutzerhandbuch nach.

Elektrische Verkabelung

WICHTIGER WARNHINWEIS!

Darauf achten, dass die Polaritäten beim Anschluss des Geräts nicht vertauscht werden. Ist dies der Fall, schaltet sich das Bedienfeld nicht ein, das Gerät funktioniert nicht.

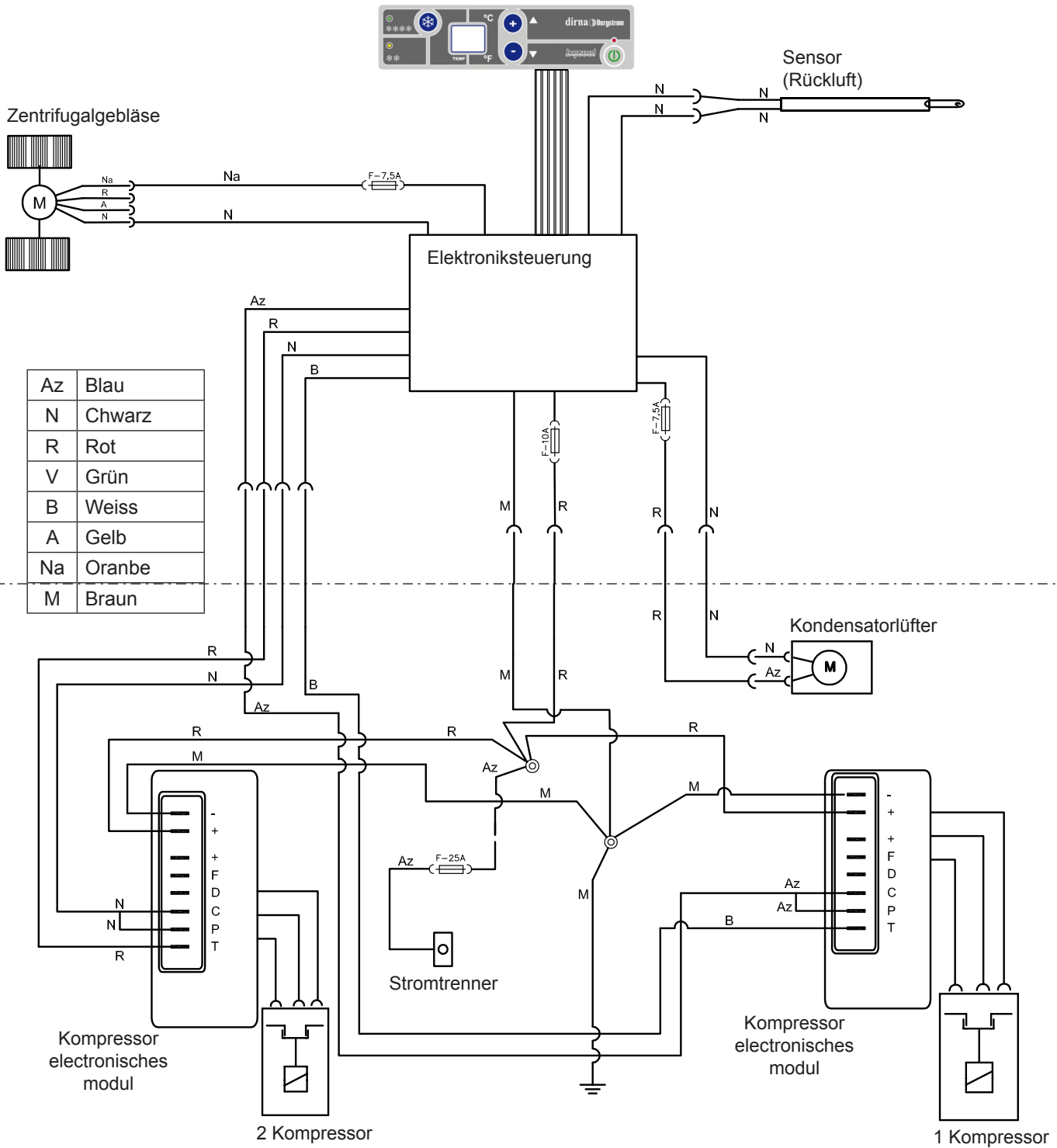

Multiple horizontal dotted lines for writing.

Suggerimenti per il montaggio

- Prima di cominciare il montaggio, leggere attentamente le istruzioni e rispettarle nel corso dello stesso.
- Usare gli attrezzi più adatti ad ogni operazione.

Elettricità

- Scollegare la chiave di contatto.
- Scollegare la batteria prima di cominciare il montaggio.
- Assicurarsi di avere effettuato correttamente l'installazione e il collegamento dei componenti elettrici.

Attenzione

Se durante il montaggio si inclina l'impianto, prima di rimetterlo in funzione occorre attendere almeno 60 minuti dal momento in cui è di nuovo in posizione orizzontale.

Documentazione allegata

Istruzioni di montaggio	1001207468
Guida dell'utente	220AA60170
Soluzione dei problemi	220AA60013
Garanzia	220AA10017

Attenzione

Quando si installa l'impianto di aria condizionata sul tettuccio, bisogna proteggere la parte superiore della cabina con uno straccio o una coperta per evitare eventuali graffi. Per l'installazione del **Compact**, tenere presente che normalmente le cabine munite di oblò dispongono di una struttura abbastanza solida per sostenere il peso dell'impianto. Tuttavia, se così non fosse e se fosse necessario tagliare il tettuccio, o se in presenza di oblò la struttura non fosse abbastanza rigida (se fosse di fibra, plastica, ecc.), è responsabilità dell'installatore decidere se occorre rinforzare il tettuccio per evitare qualsiasi deformazione, rottura o penetrazione d'acqua, ecc., prendendo le misure necessarie per evitarlo.

Attrezzi

- Kit di chiavi Torx
- Kit di chiavi Allen
- Chiave fissa 10, 13, 14
- Forbici
- Metro a nastro

Simbologia



Fragile









Attenzione alle mani



Tensione elettrica pericolosa

Avvertenze

-  L'installatore deve essere in possesso della formazione necessaria in materia di aria condizionata per veicoli.
-  **dirna Bergstrom, s.l.** declina ogni responsabilità per danni o rotture derivanti dall'errata installazione o dall'errato uso dell'impianto o da sostituzioni o modifiche effettuate senza la necessaria autorizzazione per iscritto.
-  **Impianto precaricato con gas refrigerante. (Non manomettere il circuito di gas refrigerante).**
-  Vedi la **procedura di garanzia** del prodotto in **Diagnosi dei problemi**.
-  Vedi la **Guida dell'utente** dell'impianto per il corretto funzionamento del telecomando e del pannello di controllo.
-  I seguenti documenti devono essere consegnati all'utente una volta conclusa l'installazione: **Guida dell'utente, Garanzia e Diagnosi dei problemi**.

 Prima di iniziare il montaggio, installare la griglia sull'entrata anteriore dell'aria.



1 Smontare coperchio tettuccio, gli elementi di fissaggio e consegnare al cliente (*).

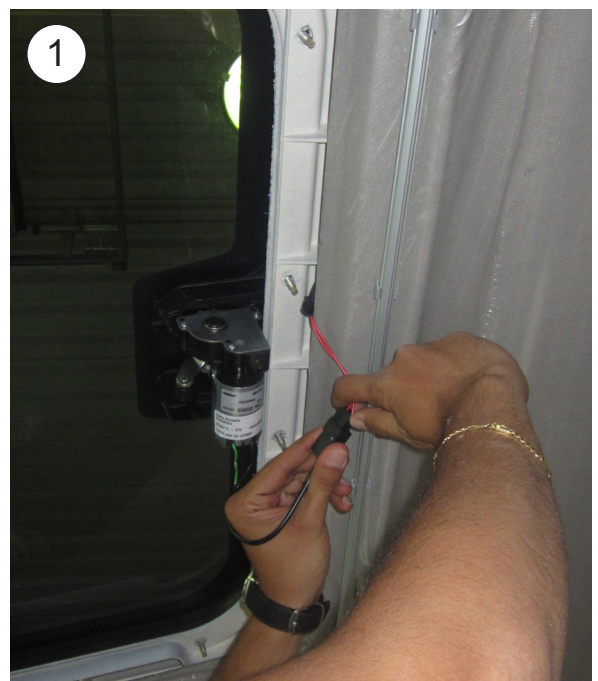
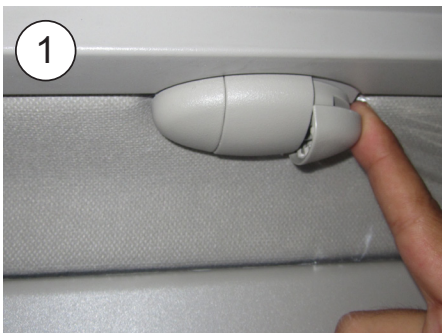

2 Rimuovere i residui in eccesso attaccato al soffitto prima di colpire la guarnizione in EPDM.

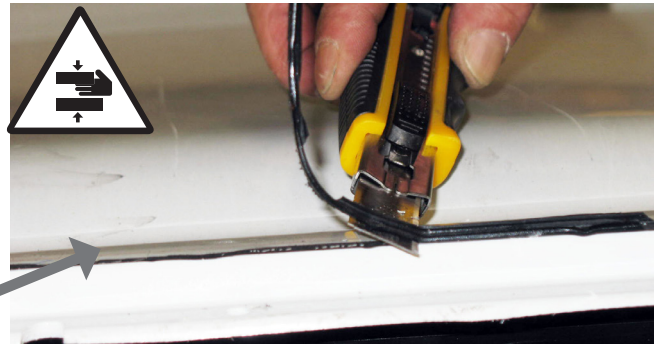

2a Incollare la guarnizione EPDM intorno al foro dell'oblò (vedi particolare per tagliare i bordi).



! **INCOLLARE LA GUARNIZIONE EPDM INTORNO AL FORO DELL'OBLO' (VEDI PARTICOLARE PER TAGLIARE I BORDI)**

A- Incollare la guarnizione mantenendo una protezione di carta di 100 mm su ogni lato.

B- Rimuovere i due pezzi di carta.

C- Incollare premendo su entrambe le estremità.

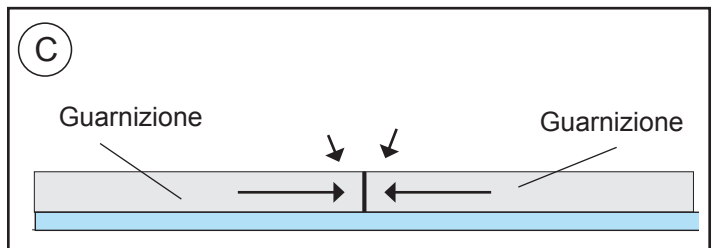
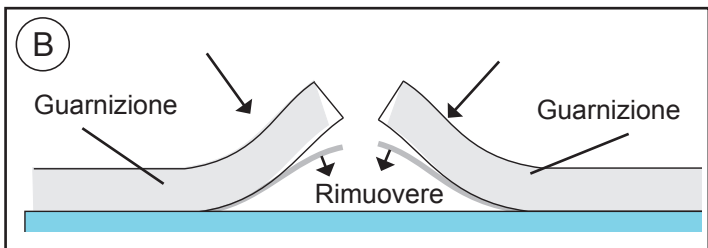
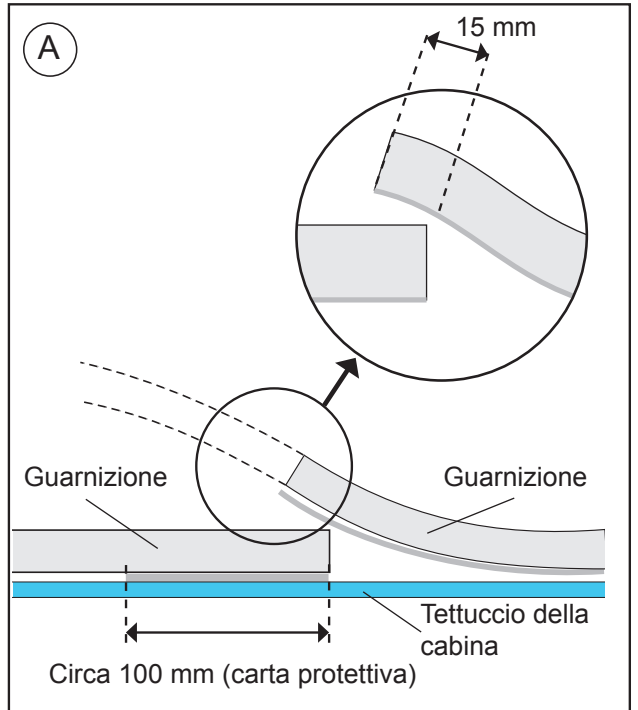

3 ESTERNO CABINA:

Inserire il Compact nel vano.

Attenzione! Quando si posiziona l'impianto sul vano del tettuccio apribile, controllare che le uscite di scarico non siano ostruite dalla guarnizione EPDM.

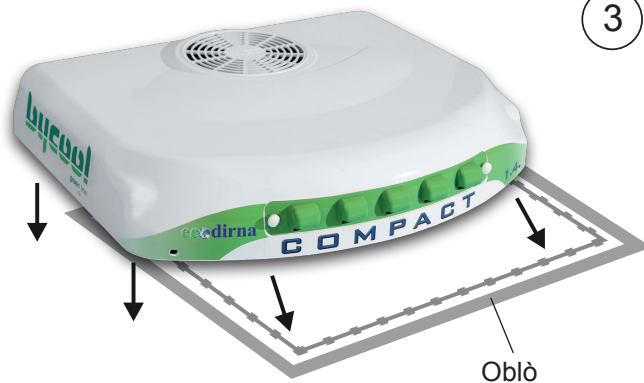

4

Posizionare il canalizzatore di gommapiuma con la parte più morbida sulla base dell'impianto.

Attenzione: A seconda della cabina, può essere necessario usare i (2) canalizzatori in dotazione per la completa adesione del pannello di distribuzione dell'aria ai medesimi.



5

INTERNO CABINA:

Avvitare di circa 5 mm le (4) viti prigioniera da 8/125x100.

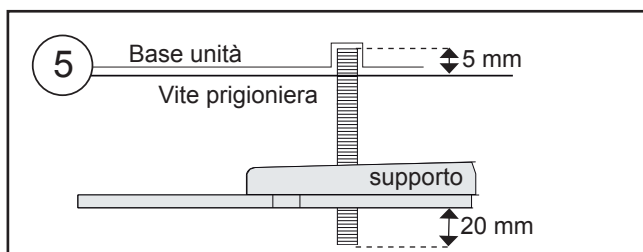

6

Inserire (8) rondella di gomma Ø 7, (1) rondella piana Ø 1 a testa larga, (2) dadi M8 e (1) rondella piana Ø 8 a testa larga, su ciascuna vite prigioniera precedente, seguendo questo ordine.

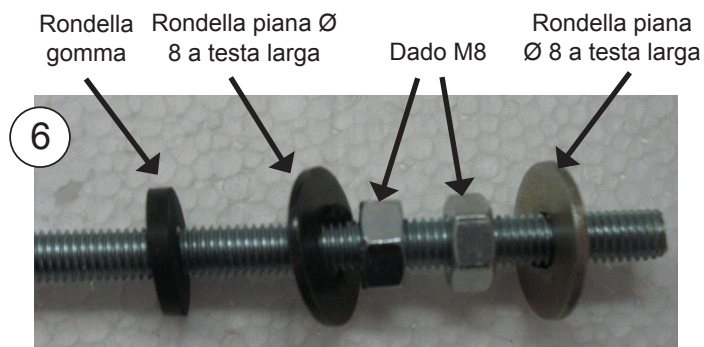

- 7** Fissare i supporti di fissaggio (2), con una rondella (1) e un dado autobloccante (1) M8, senza stringere.



- 8** Avvitare di 10 mm i perni (4) M6 x 55 o 80, dove indicato distanza (A) segun nella a figura 17.

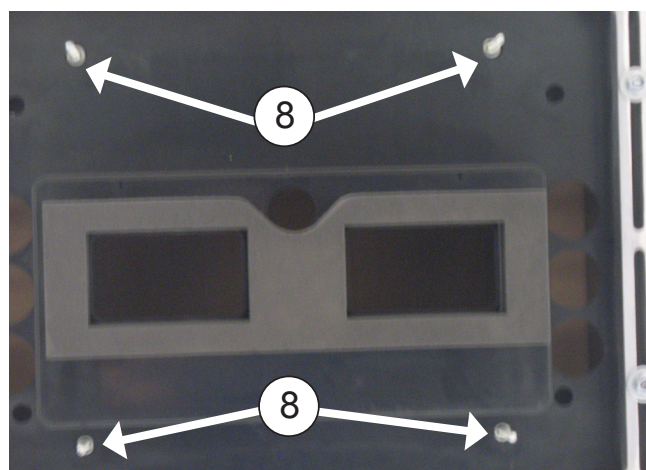
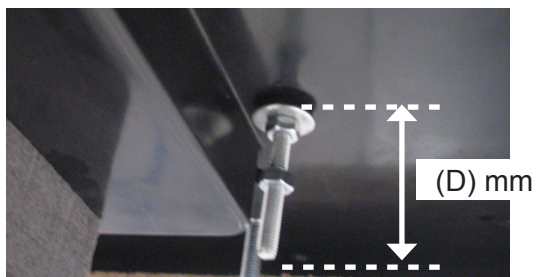

- 9** Inserire (1) rondella Ø 6 di gomma, (1) rondella piana Ø 6 a testa larga e (1) dado M6 su ogni vite prigioniera M6. Quindi stringere il dado fino a premere leggermente la rondella di gomma.

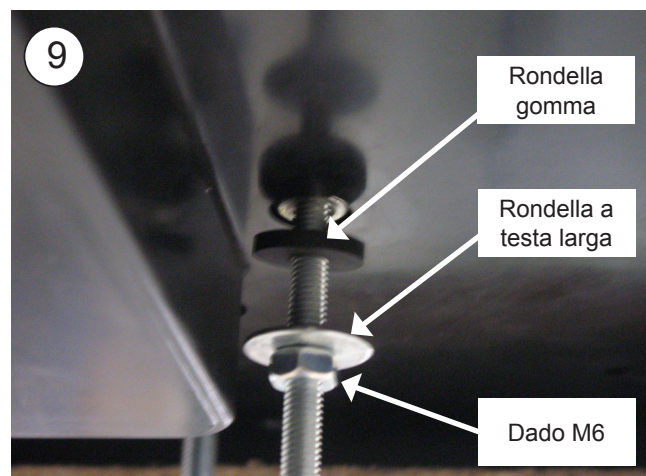

10 Inserire il dado (1) M6 **senza stringere** in ogni vite prigioniera.

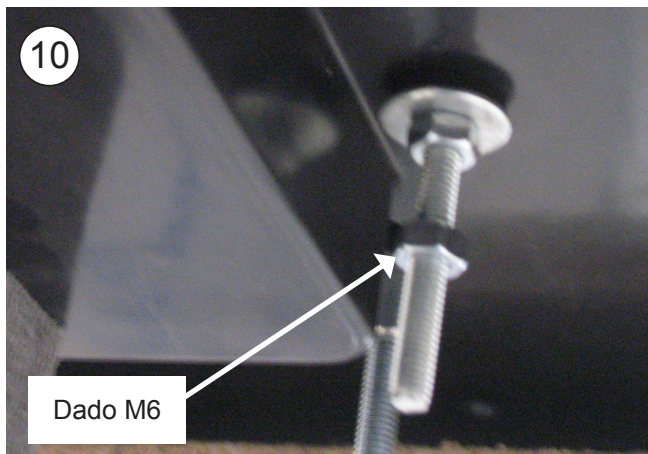
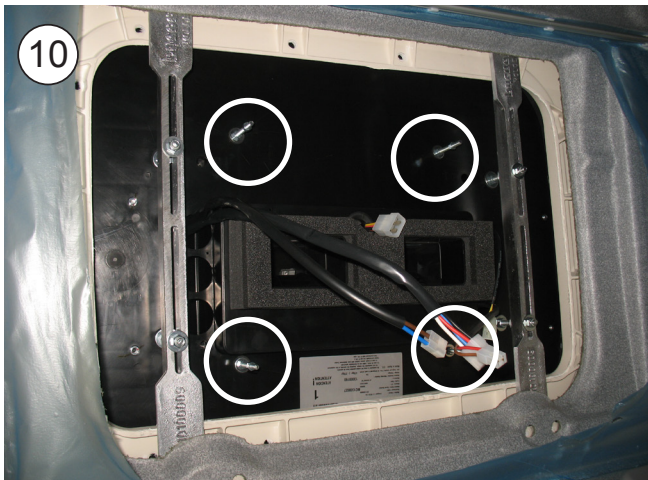

11 Collegare la scatola a 2 vie del sensore dell'aria di ritorno, la scatola a 4 vie del ventilatore e quella a 8 vie di connessione dei cablaggi del controllo elettronico.

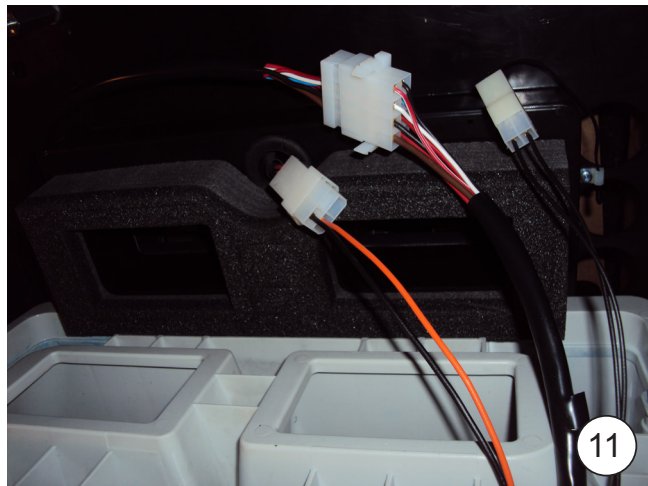

12 Posizionare il pannello interno di distribuzione dell'aria sulle viti prigioniera anteriori con (1) rondella M6 a testa larga e (1) dado M6 su ogni vite prigioniera. Stringere i dadi finché il canalizzatore del pannello interno di distribuzione dell'aria non è a battuta sulla gommapiuma superiore dell'impianto.

Nota bene: il canalizzatore del pannello interno di distribuzione dell'aria deve essere a battuta sulla gommapiuma superiore dell'impianto per evitare perdite d'aria.

Evitare che i cablaggi restino impigliati tra il canalizzatore e la gommapiuma sulla base dell'impianto.

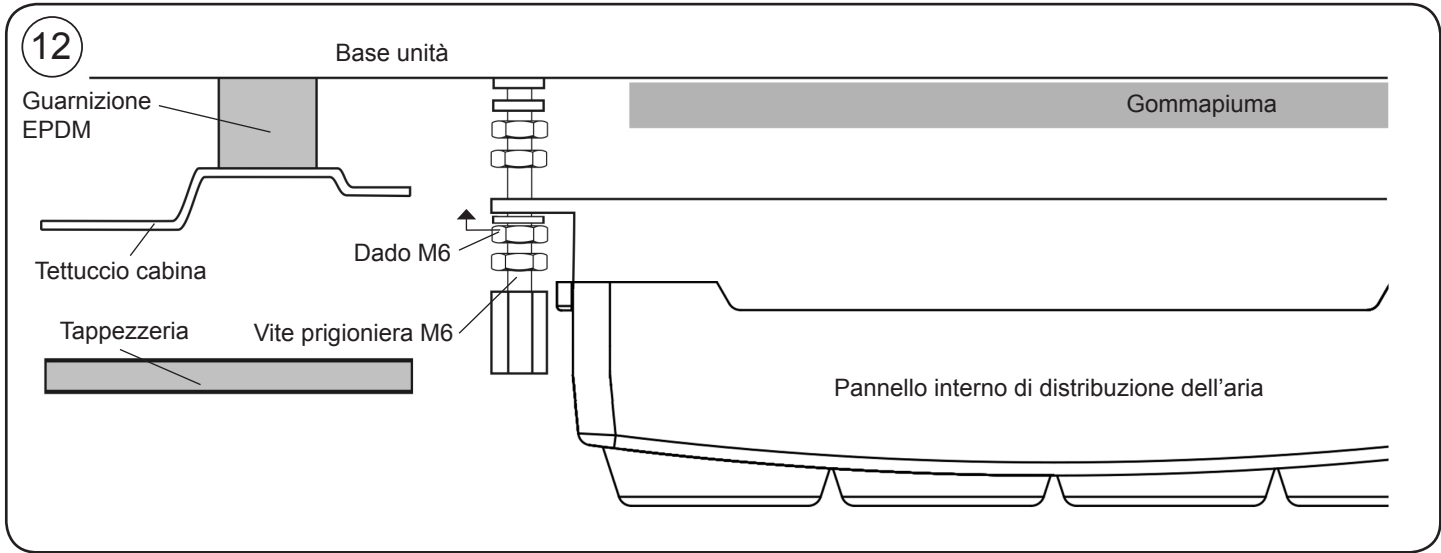

13 Stringere il dado del punto 10 fino a battuta con la parte superiore del pannello interno di distribuzione dell'aria.

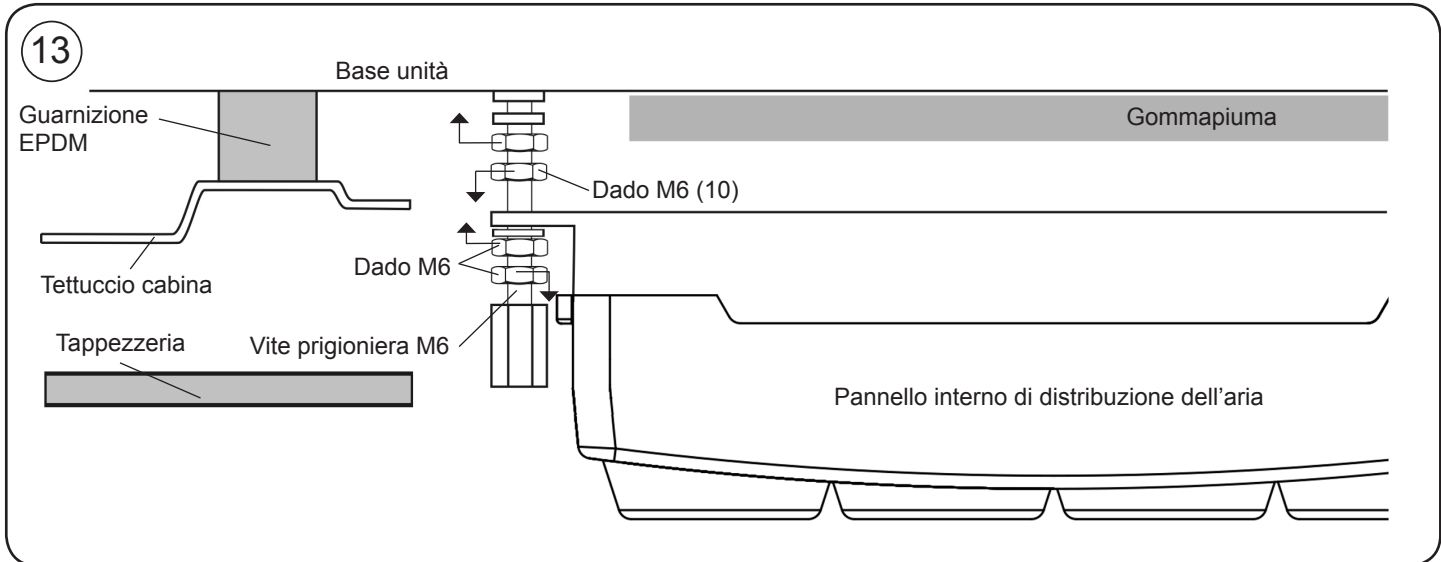

14 Inserire la consolle e centrare l'impianto nella parte più adatta del tettuccio della cabina. Una volta centrato, rimuovere la consolle per la successiva installazione.



15 Fissare i supporti stringendo i dadi fino a comprimere, tra 3 e 6 mm, la guarnizione EPDM dell'impianto.

Nota bene: Per evitare che infiltrazioni d'acqua nella cabina, verificare il serraggio della guarnizione EPDM con la base Compact base, come illustrato nel Diagramma.



Controllare la compressione guarnizione in EPDM con un metro a nastro ai quattro angoli.

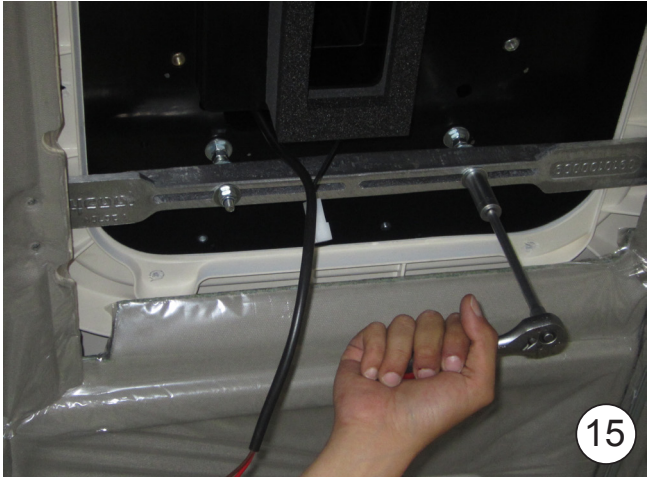
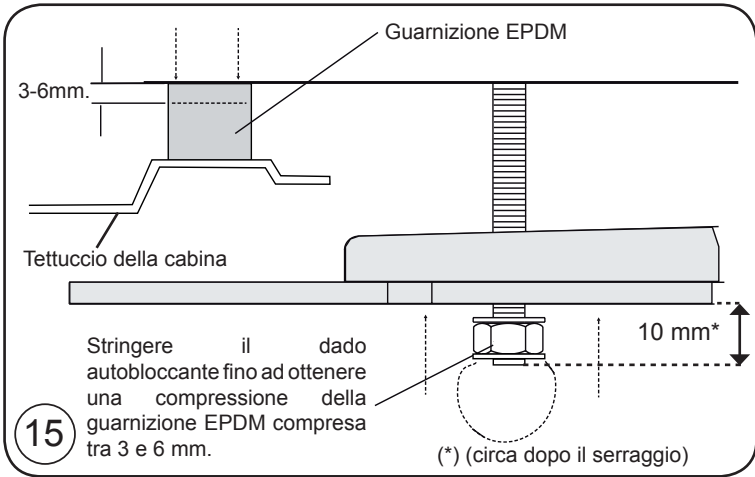

16 Stringere i dadi (4) M8 per fissare a (4) l'unità base.

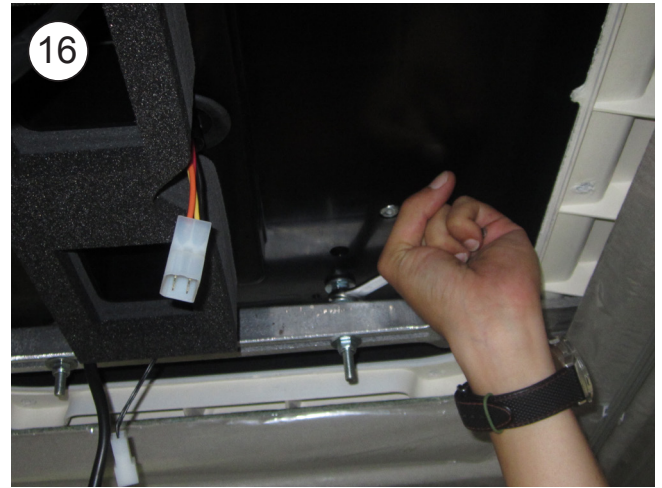

17 Inserire il dado M6 (A) sul dado di fissaggio del pannello interno di distribuzione dell'aria su ogni vite prigioniera. Inserire i perni esagonali M6 e avvitarli fino a lasciarli a 1 mm al di sopra della tappezzeria. Svitare i dadi M6 (A) di questo punto fino a battuta con i perni esagonali e stringerli contro gli stessi.

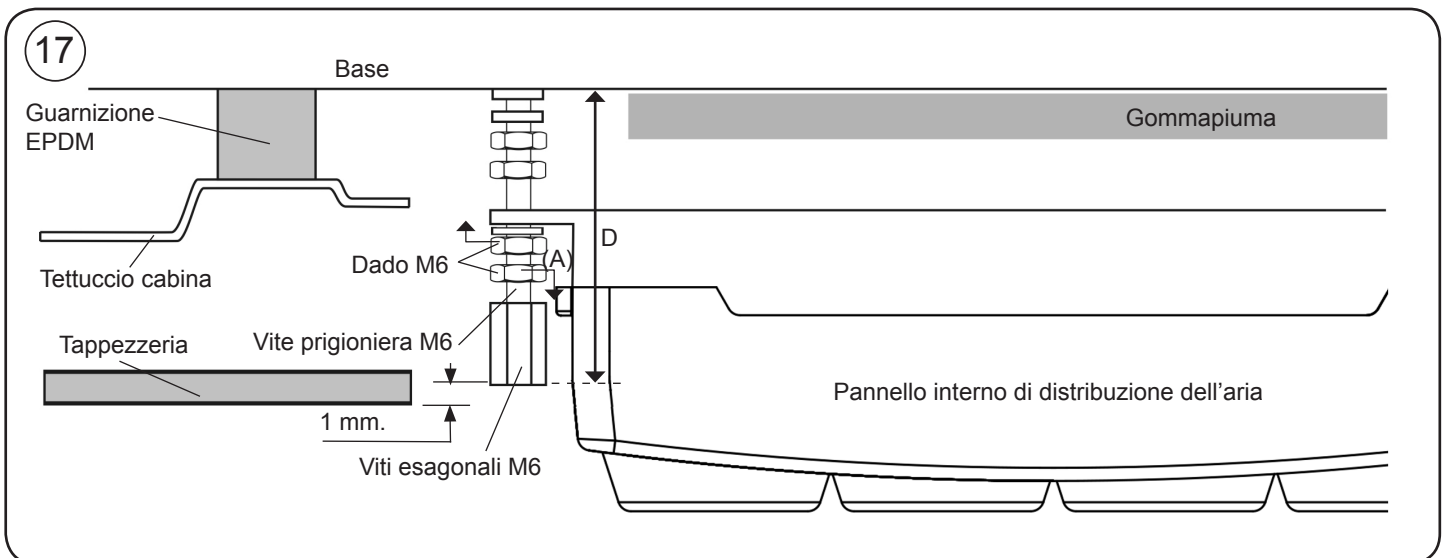
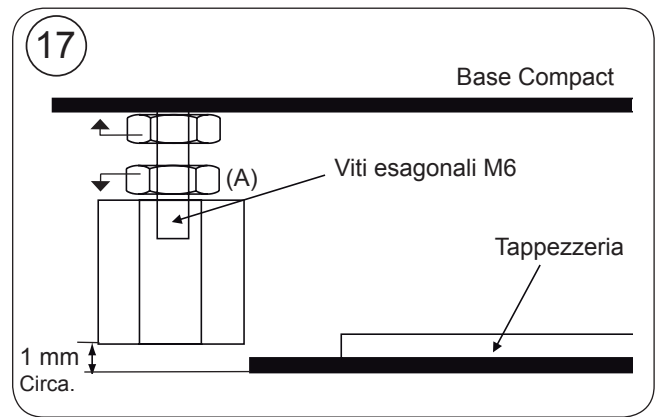

18 Posizionare la console usando (4) viti a brugola M6/100x15.

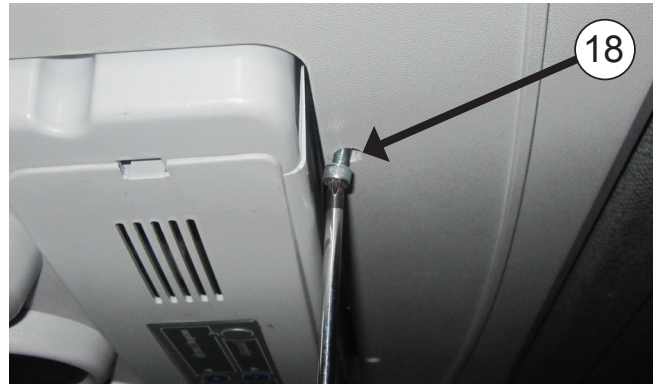

19 Collocare sugli stessi le decorazioni rotonde di plastica M6.

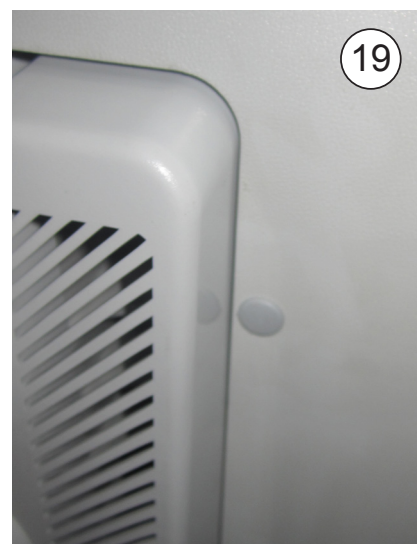

20 Avvitare (4) viti 6/100x15 sull'elemento decorativo della console originale e tapparle con il tappo dei dadi.



Esploso fino al fissaggio dei supporti di fissaggio

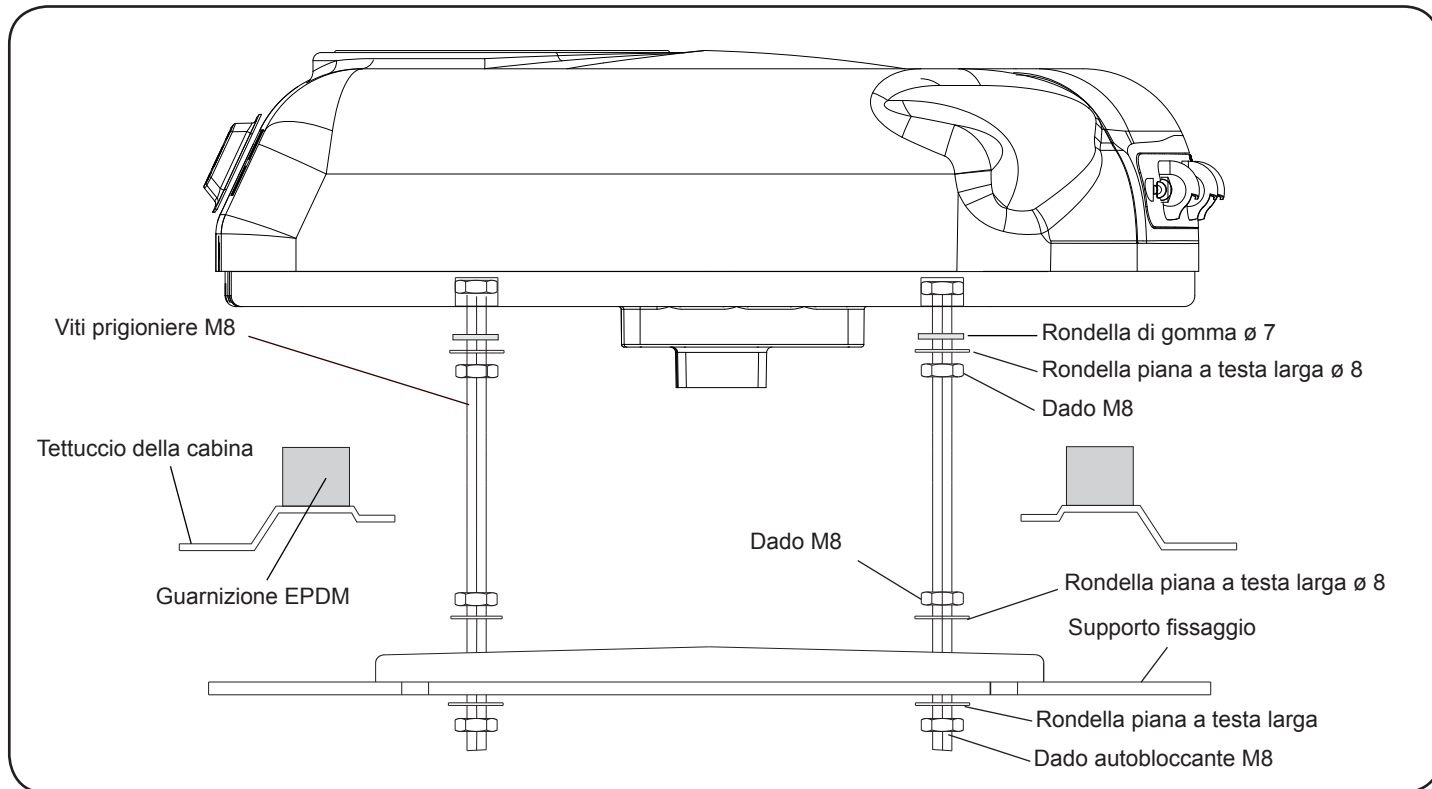

Esploso fino al fissaggio della consolle

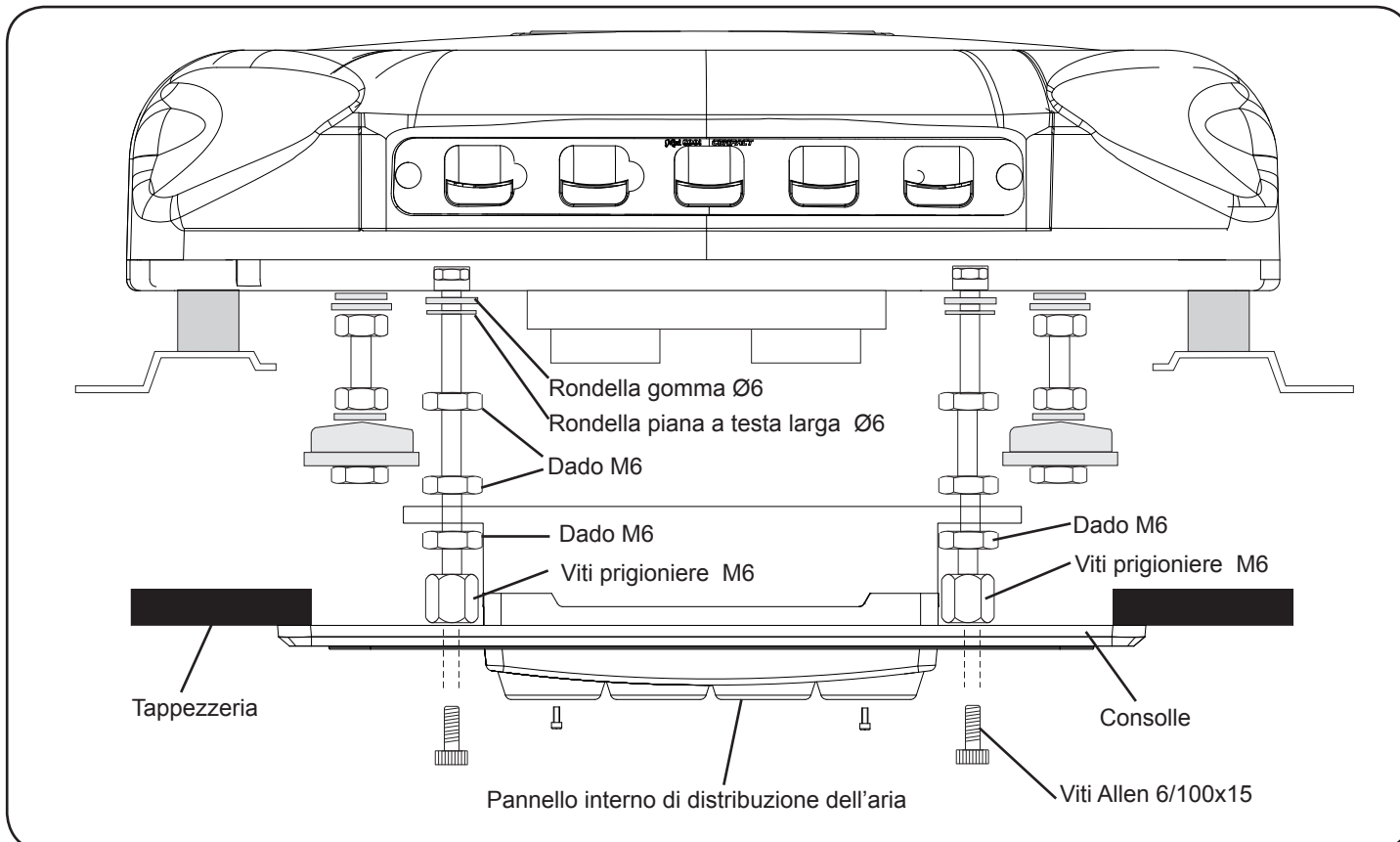

Istruzioni dettagliate Sull'installazione del cablaggio di alimentazione

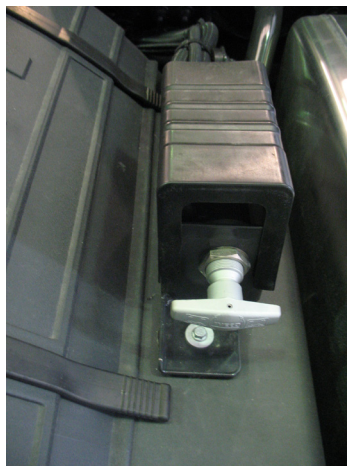
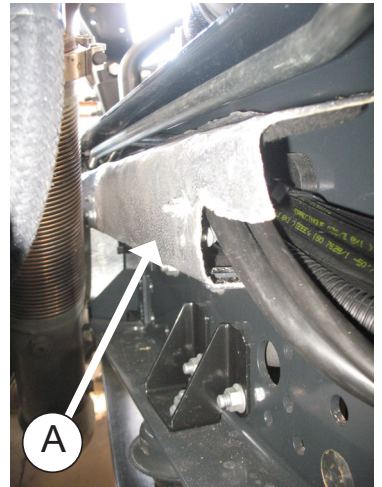

1

Condurre il cavo di alimentazione dell'impianto fino al sezionatore di corrente (*positivo*) e il punto di massa (*negativo*) del veicolo, incollando i supporti di plastica sulla parte posteriore della cabina e fissando con le fascette; quindi con la cabina ribaltata, far passare il cavo dalla parte inferiore della stessa fissandolo con le ghiera e le viti M4; e fino alla batteria con le fascette; occorre usare lo stesso passaggio del cablaggio originale (*all'interno della protezione del tubo di scappamento (A)*). (*Pulire bene la zona prima di incollare i supporti di plastica*). Quando si collega l'impianto alla batteria, lo stesso esegue un test di tutti i led e sul display compare la dicitura **88-bd**, quindi si spegne.



NOTA BENE: per l'avviamento, vedi il Manuale dell'utente.

Cablaggio elettrico

AVVISO IMPORTANTE!

Fare attenzione a non invertire le polarità quando si esegue il collegamento dell'impianto. Altrimenti, il quadro comandi non si accenderebbe, l'impianto non funzionerebbe.

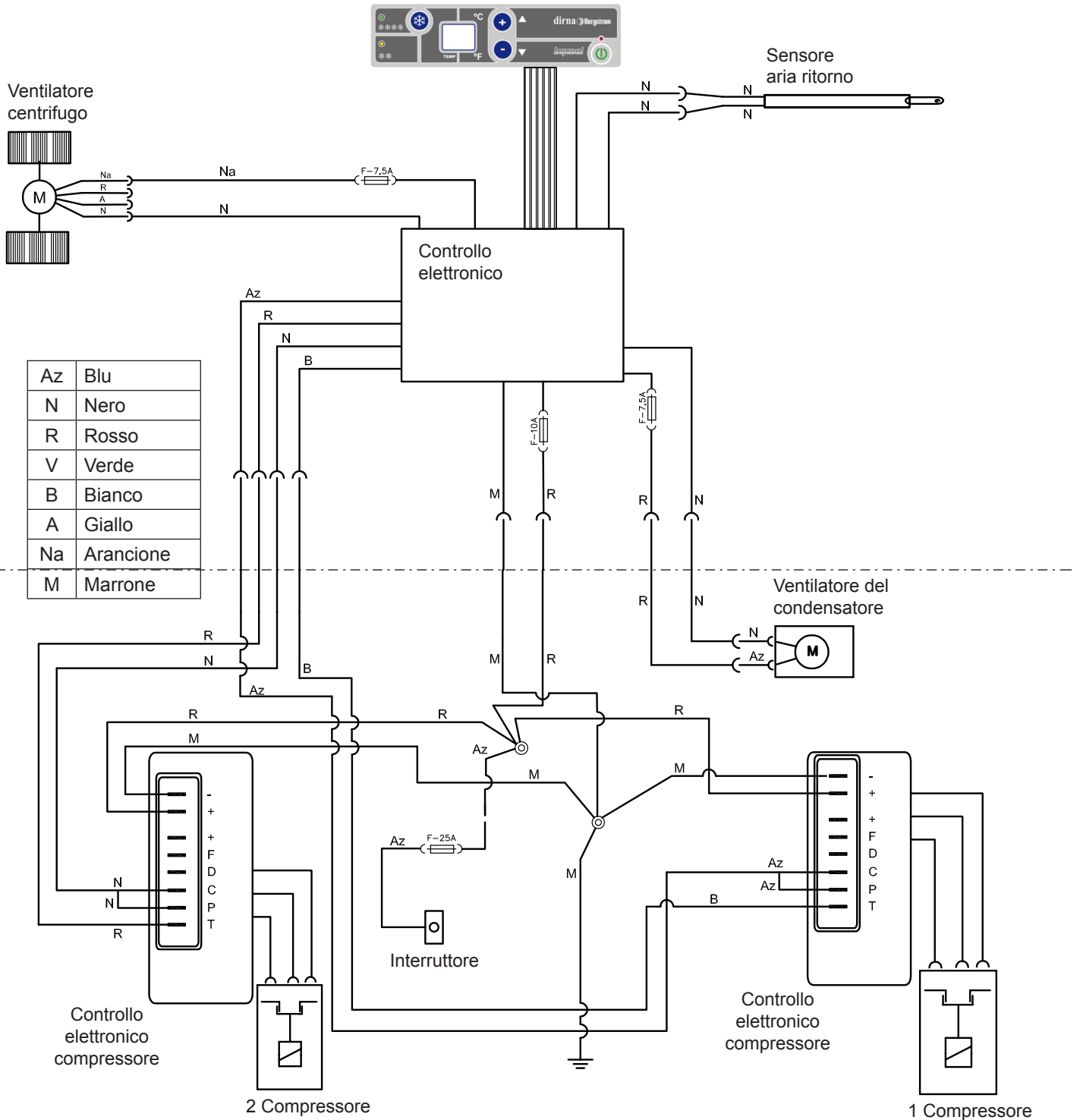

Zalecenia Dotyczące montażu

- Przed rozpoczęciem montażu należy zapoznać się z instrukcją i stosować się do niej podczas prac instalacyjnych.
- Do każdej czynności stosować odpowiednie narzędzia.

Instalacje elektryczne

- Wyjąć / wyłączyć pojazd kluczykami.
- Przed rozpoczęciem prac montażowych odłączyć akumulator.
- Zabezpieczyć podłączenie komponentów elektrycznych, sprawdzając, czy wtyki pasują do gniazd.

Uwaga

Jeżeli podczas montażu urządzenie zostanie przechylone lub zostanie odchylona kabina, nie należy uruchamiać go przez co najmniej 60 min. po ustawieniu w poziomie.

Uwaga

Instalując sprzęt klimatyzacyjny na dachu należy osłonić górne części kabiny za pomocą materiału lub koca ochronnego w celu uniknięcia zarysowań. Instalując urządzenie **Compact** na dachu należy wziąć pod uwagę fakt, że zazwyczaj kabiny wyposażone w otwór dachowy mają wystarczająco wytrzymałą konstrukcję dla utrzymania ciężaru sprzętu. Jeżeli jednak będzie konieczne wykonanie cięcia w dachu lub jeżeli materiał otworu dachowego nie jest wystarczająco wytrzymały (w przypadku dachów z włókna, tworzywa sztucznego itp.), osoba przeprowadzająca montaż powinna podjąć **na własną odpowiedzialność** decyzję, czy istnieje potrzeba wzmocnienia dachu w celu uniknięcia deformacji, pęknięć, przecieków itp.

Narzędzia

- Komplet kluczy Torx
- Komplet kluczy imbusowych
- Klucz płaski 10, 13, 14
- Nożyczki
- Fleksometr

Symbole



Kruche



Grozi skaleczeniem!





Ryzyko porażenia

Załączona dokumentacja

Instrukcja montażu	1001207468
Instrukcja użytkownika	220AA60170
Diagnostyka awarii	220AA60013
Gwarancja	220AA10017

Ostrzeżenia

 Osoby odpowiedzialne za montaż powinny posiadać odpowiednie przeszkolenie w zakresie klimatyzacji w pojazdach.

 **dirna Bergstrom, s.l.** nie ponosi odpowiedzialności w przypadku wystąpienia usterek wynikających z nieprawidłowej obsługi lub instalacji urządzenia oraz powstałych na skutek modyfikacji i wymiany części bez pisemnej zgody producenta.

 **Urządzenie napełnione czynnikiem gazowym chłodzącym. (Nie ingerować w obieg czynnika chłodzącego!).**

 Sposób **zgłaszania gwarancji** znajduje się w części **Diagnostyka awarii**.

 **Instrukcja obsługi** zawiera opis prawidłowego użytkowania pilota i panelu sterowania.

 Po zakończeniu montażu należy przekazać użytkownikowi: **Instrukcję obsługi, Kartę gwarancyjną i Diagnostykę awarii**.

 Przed rozpoczęciem instalacji, kratka wlotu powietrza z przodu zamontować.



1 Zdemontuj pokrywę otworu dachowego i elementy mocujące — zwróć je klientowi (*).

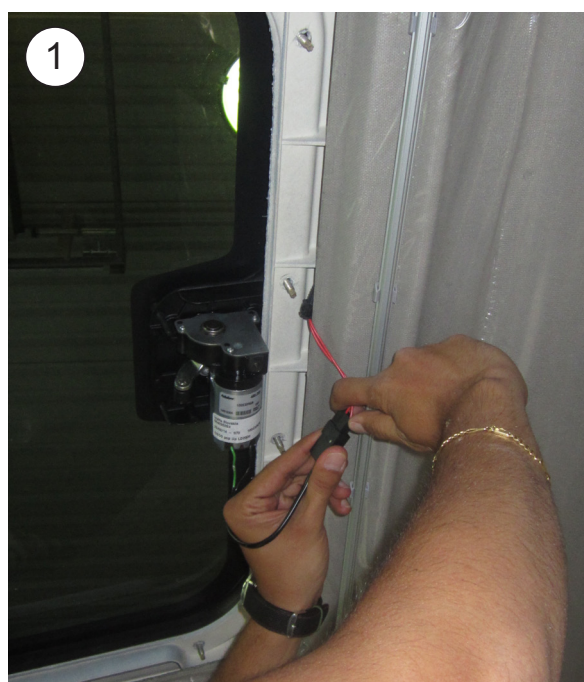
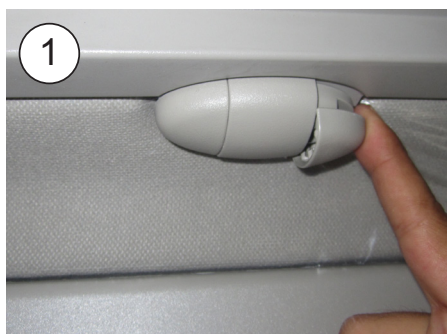

2 Usuń pozostałości kleju na dachu, a następnie zamontuj uszczelkę EPDM.

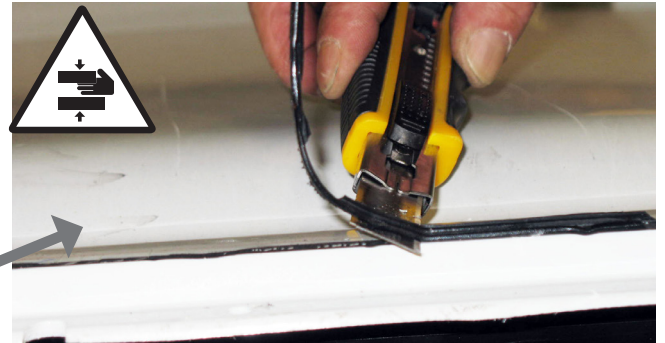

2a Załóż uszczelkę EPDM na krawędzie otworu dachowego (na rysunku szczegółowym jest przedstawiony sposób docięcia końców uszczelki).



SPOSÓB DOCIĘCIA USZCZELKI EPDM DLA A ZACHOWANIA WODOSZCZELNOŚCI KABINY

- A-** Przyklej uszczelkę zachowując papier zabezpieczający z obu stron na odcinku 100 mm.
- B-** Zdejmij odcinki papieru.
- C-** Przyklej dociskając oba końce.

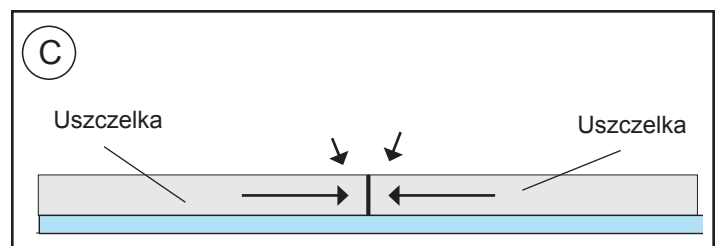
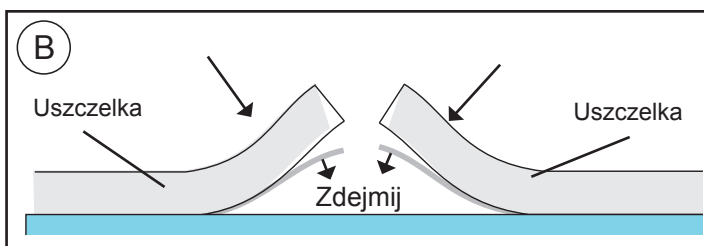
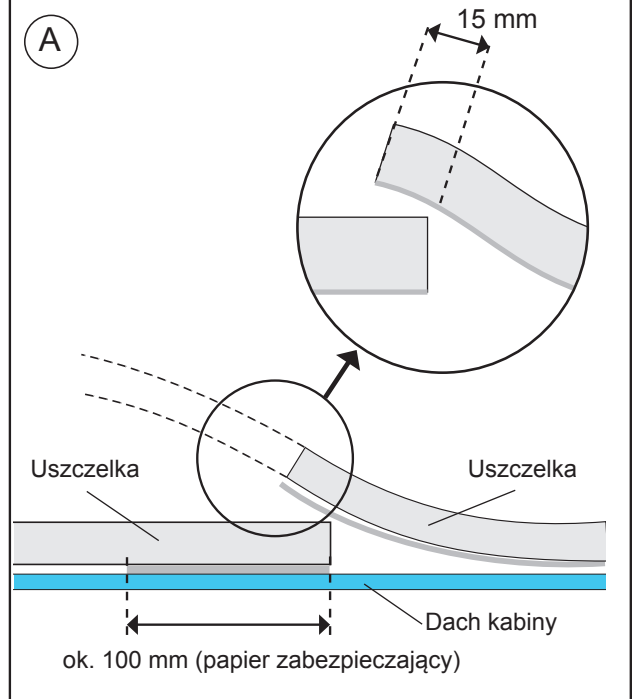

3

NA ZEWNĄTRZ KABINY:

Ustaw urządzenie w otworze dachowym.

Uwaga! Po umieszczeniu urządzenia nad otworem luku sprawdzić, czy wyloty przewodu odpływowego nie zostały zasłonięte uszczelką EPDM.



3

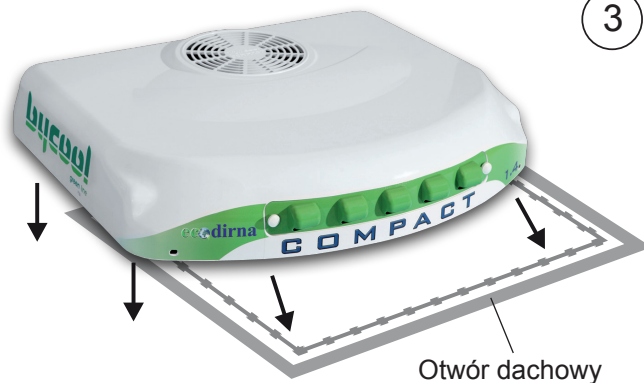

4

Umieścić przewód prowadzący z gumy piankowej tak, żeby bardziej miękka część znajdowała się w podstawie urządzenia.

Uwaga: W zależności od kabiny mogą być konieczne (2) dołączone przewody prowadzące, żeby za ich pomocą dokładnie osadzić panel rozprowadzenia powietrza.



5

W KABINIE:

Wkręć na około 5 mm (4) kołki gwintowane 8/125x100.

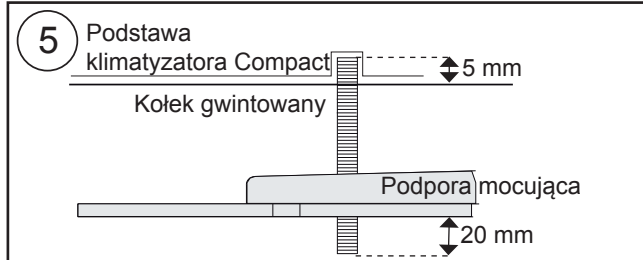

6

Na każdym kołku gwintowanym zamontuj (1) gumową podkładkę Ø 7, (1) podkładkę płaską Ø 8 szeroką, (2) nakrętki M8 i (1) podkładkę płaską Ø 8 szeroką; w podanej kolejności.

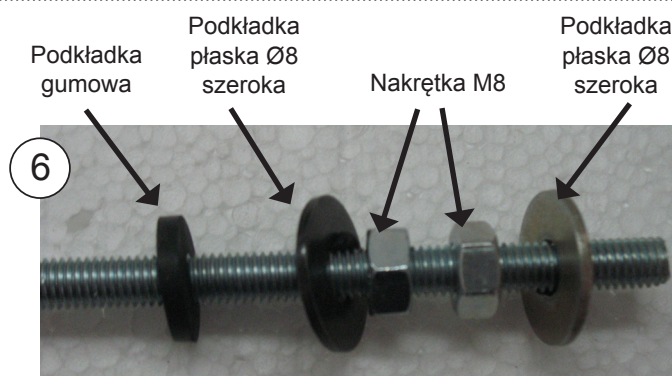

7 Załóż (2) podpory mocujące z (1) podkładką i (1) nakrętką samokontrującą M8 bez dokręcania.



8 Wkręć we wskazanym miejscu na głębokość 10 mm (4) kołki gwintowane M6 x 55 lub 80 zachowując odległość (D) przedstawioną na schemacie w pkt. 17.

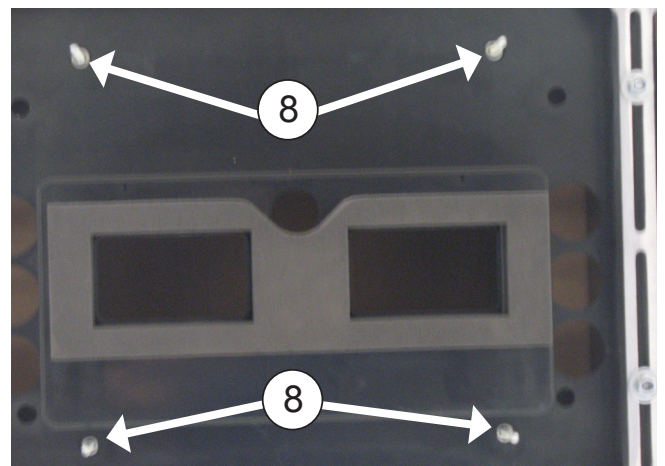
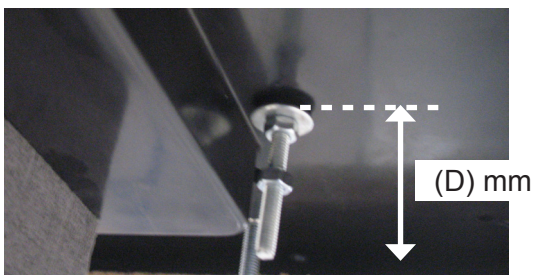

9 Na każdym kołku gwintowym M6 zamontuj (1) gumową podkładkę Ø6, (1) podkładkę płaską Ø6 szeroką i (1) nakrętkę M6. **Nakręć nakrętkę**, a następnie dokręć ją mocniej w taki sposób, aby lekko docisnąć gumową podkładkę.

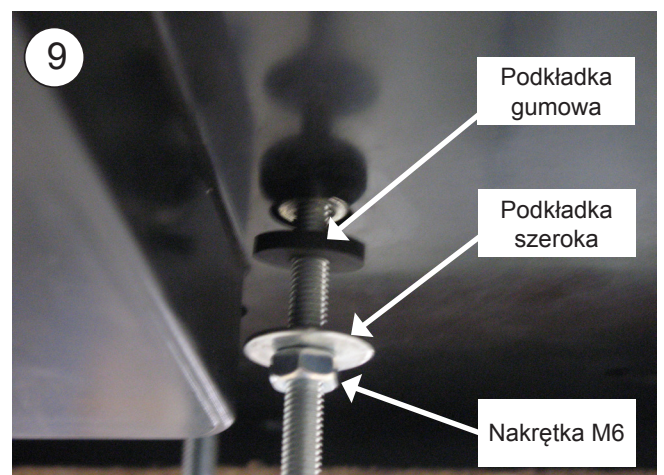

10 Na każdym kołku gwintowym zamontuj (1) nakrętkę M6 **bez dokręcania**.

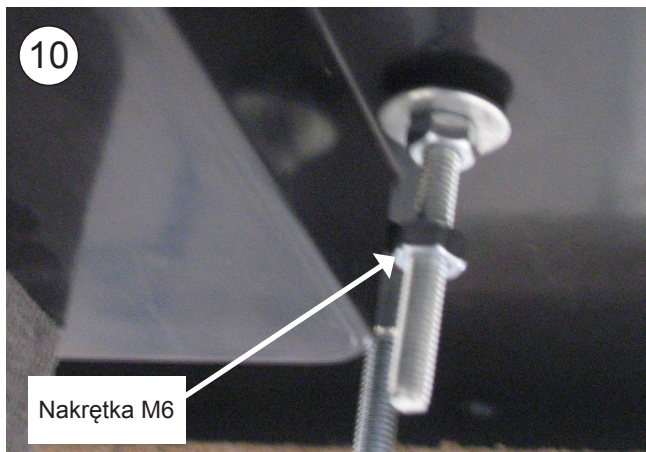
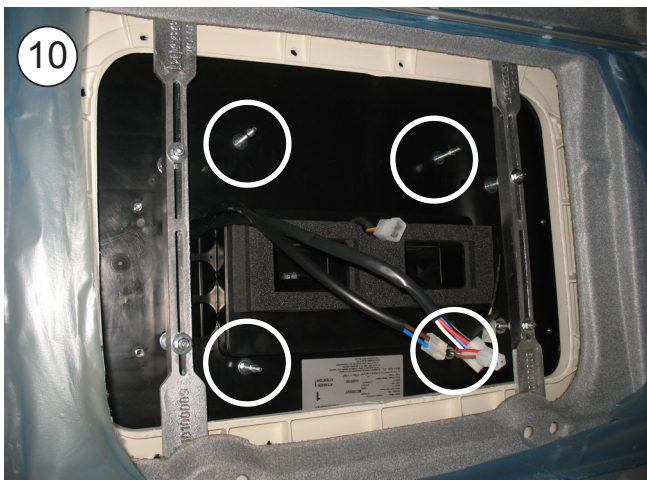

11 Podłączyć obudowę z 2 otworami czujnika powietrza powrotnego, obudowę z 4 otworami dmuchawy oraz obudowę z 8 otworami do podłączenia kabli sterowania elektronicznego.

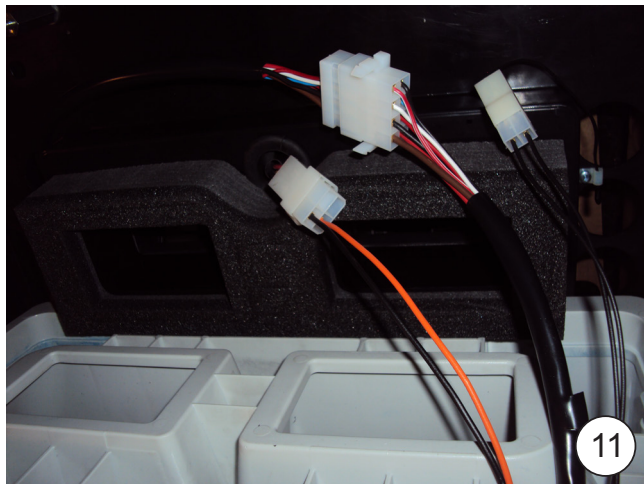

12

Umieścić wewnętrzny panel rozproszania powietrza na przednich kołkach gwintowanych z (1) szeroką podkładką M6 i (1) nakrętką M6 na każdym kołku. Dokręcić nakrętki, żeby przewód prowadzący wewnętrznego panelu rozproszania powietrza stykał się z górną gumą piankową urządzenia.

Ważna informacja: Przewód prowadzący wewnętrznego panelu rozproszania powietrza musi stykać się z górną gumą piankową urządzenia, aby nie dopuścić do wycieków powietrza.

Należy uważać, aby nie zahaczyć o kable między przewodem prowadzącym i gumą piankową umieszczoną w podstawie urządzenia.

12

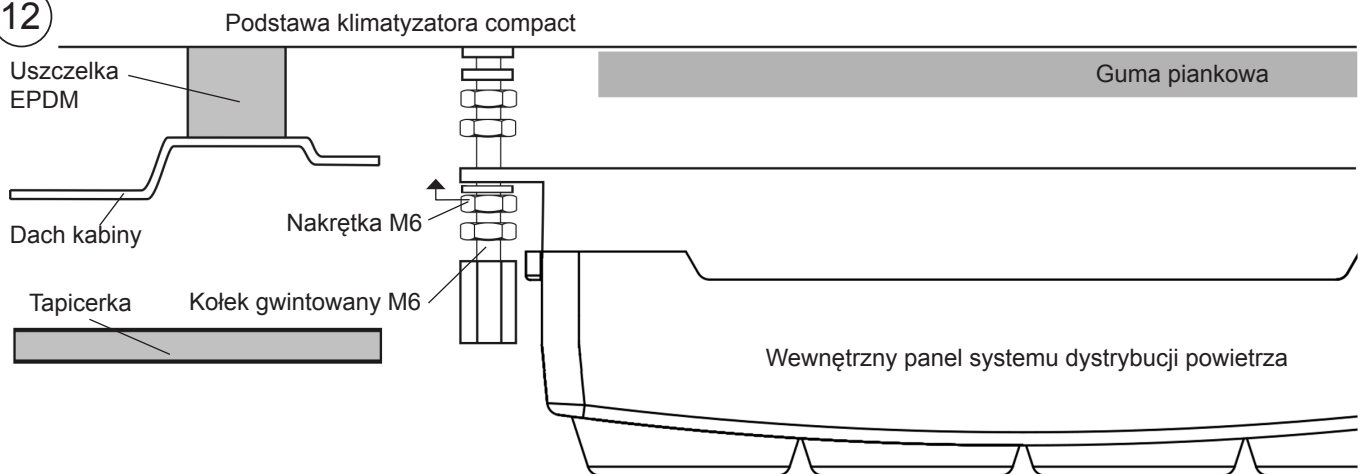

13

Dokręć nakrętkę punkt 10 w taki sposób, aby przylegała do górnej części obudowy.

13

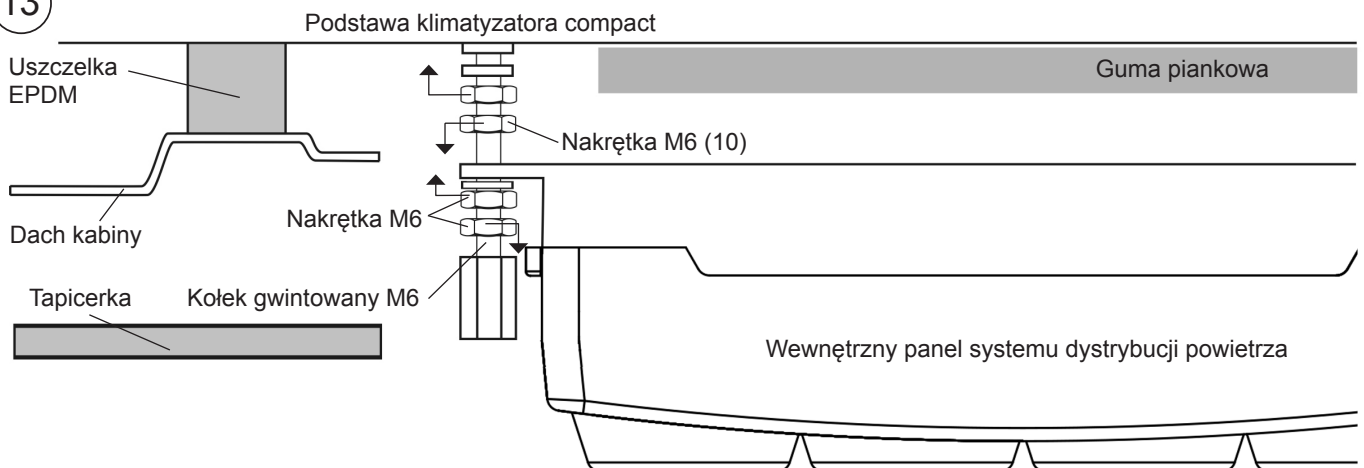

14

Przymierz konsolę i dopasuj odpowiednio urządzenie na dachu kabiny. Po ustawieniu jego pozycji zdejmij konsolę.



15

Dokręć nakrętki podpór mocujących w taki sposób, aby docisnąć zewnętrzną uszczelkę EPDM o 3 - 6 mm.

Ważne: Aby uniknąć przecieków wody do kabiny, dokręć uszczelkę EPDM do podstawy klimatyzatora Compact w sposób przedstawiony na schemacie.



Sprawdź ucisk w uszczelce EPDM przy użyciu fleksometru w czterech rogach.

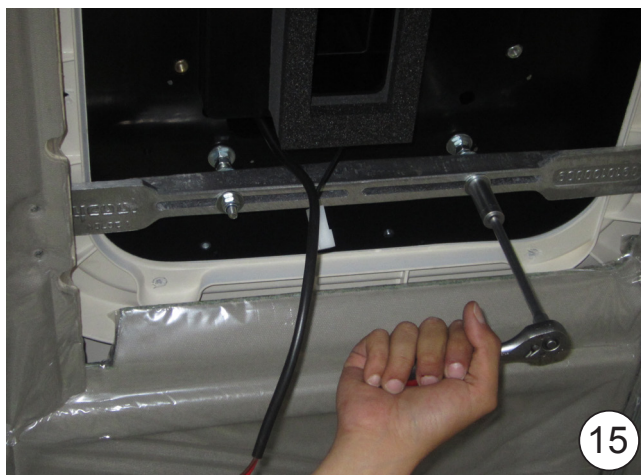
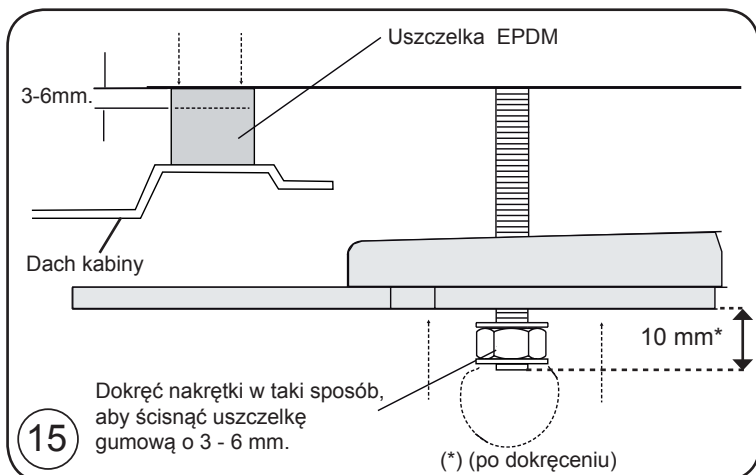

16 Dokręć (4) nakrętki M8 do podpory mocującej i (4) do podstawy klimatyzatora Compact.



17 Umieścić nakrętkę M6 (A) za nakrętką mocującą wewnętrzny panel rozprowadzenia powietrza w każdym kołku gwintowanym. Umieścić gwintowany kołek sześciokątny M6 i wkręcić go tak, żeby wystawał 1 mm nad tapicerką. Odkręcić nakrętkę M6 (A) tak, żeby stykała się z gwintowanymi kołkami sześciokątnymi, i dokręcić ją do kołków.

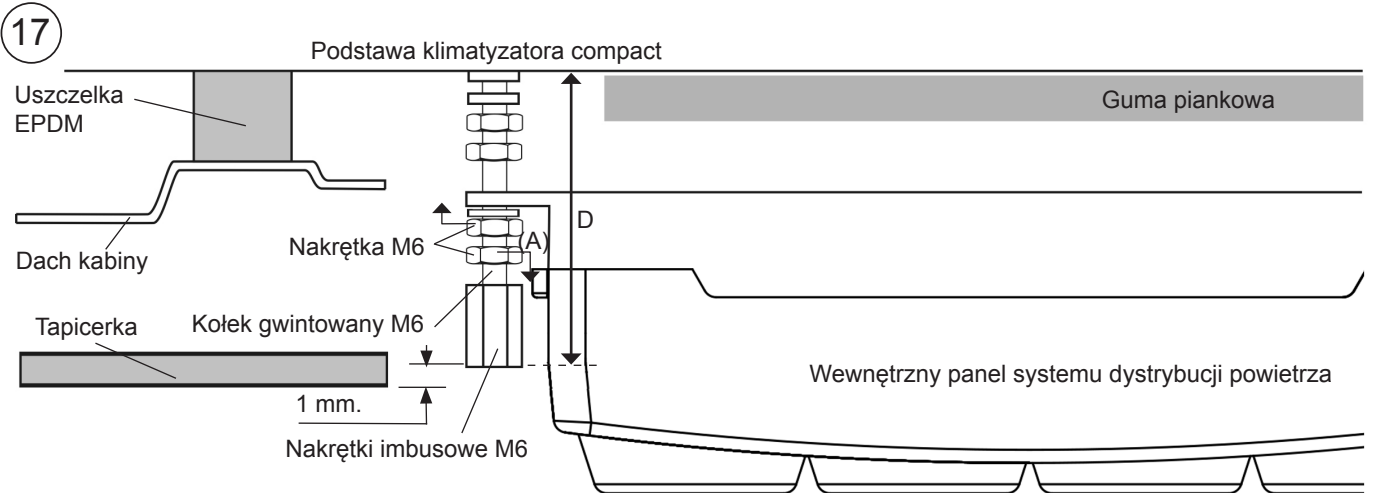
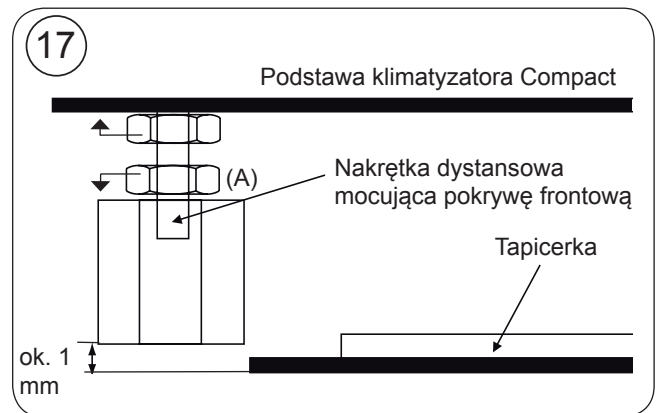

18 Przykręć konsolę za pomocą (4) nakrętek imbusowych M6/100x15.



19 Zakryj (4) nakrętki imbusowe M6/100x15 okrągłymi zaślepkami plastikowymi M6.

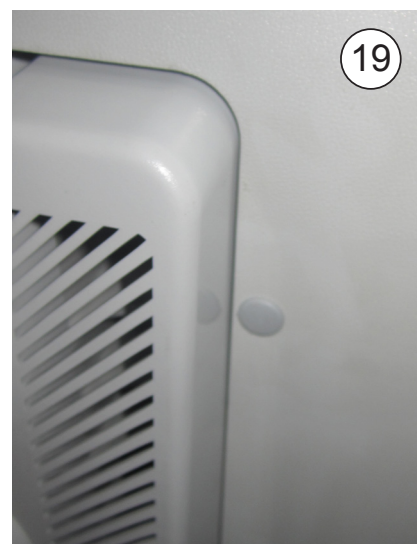

20

Wkręć (4) śruby 6/100x15 w listwę oryginalnej konsoli i zakryj je zaślepkami do śrub.



Schemat montażu do momentu mocowania wsporników

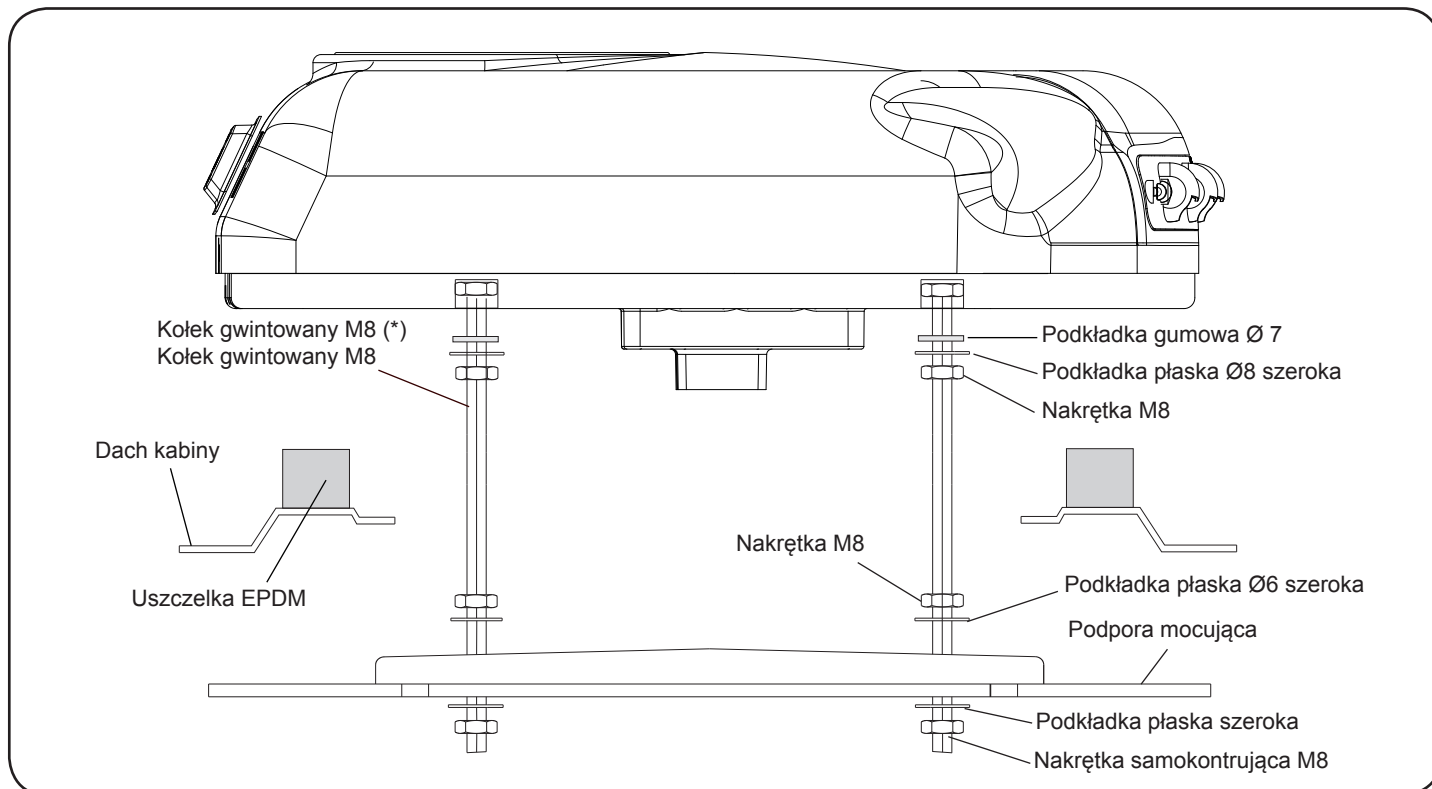

Schemat boczny montażu do momentu mocowania wsporników

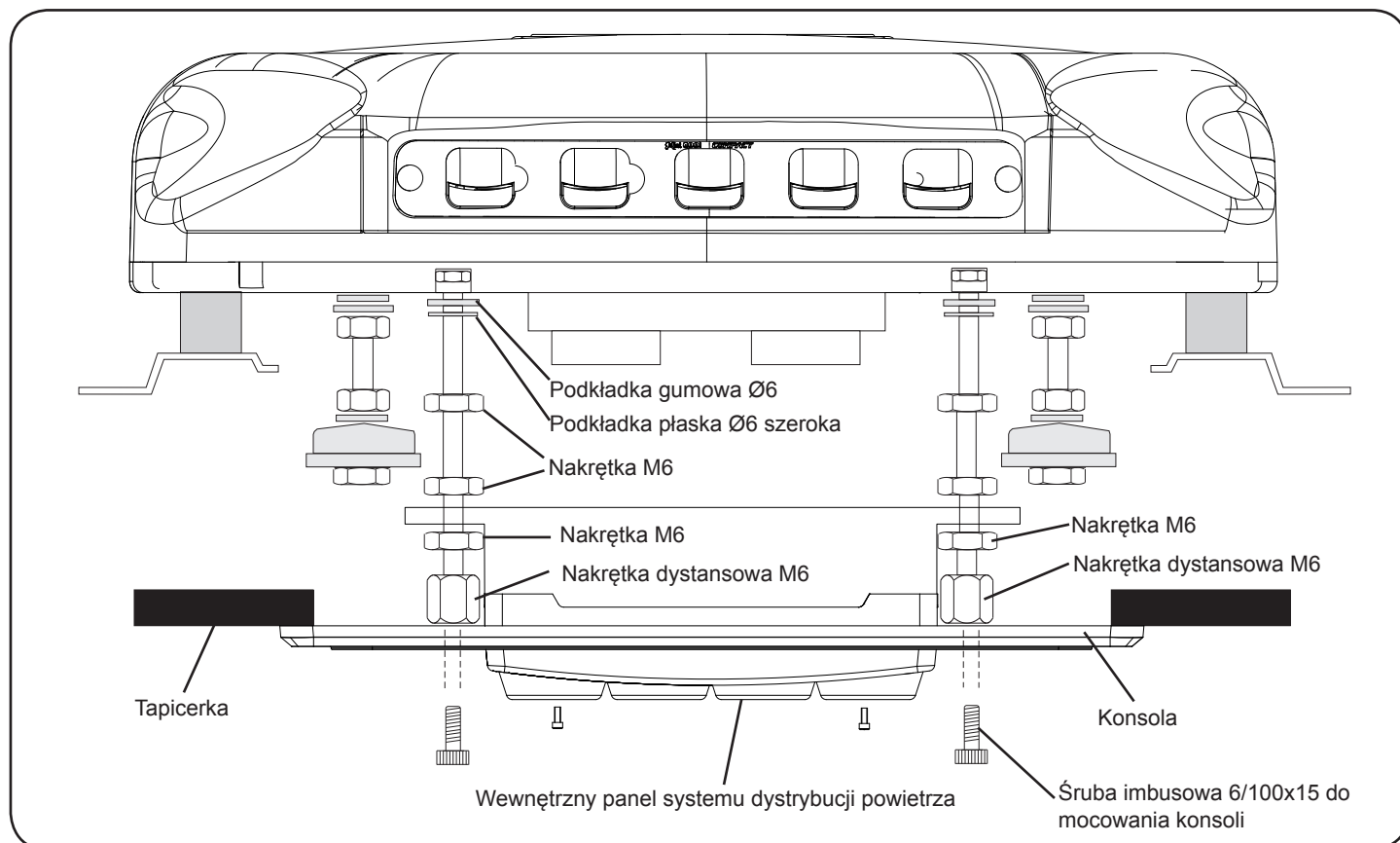

Szczegółowe instrukcje instalacji zasilającej

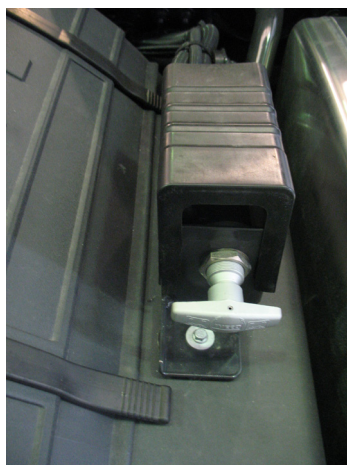
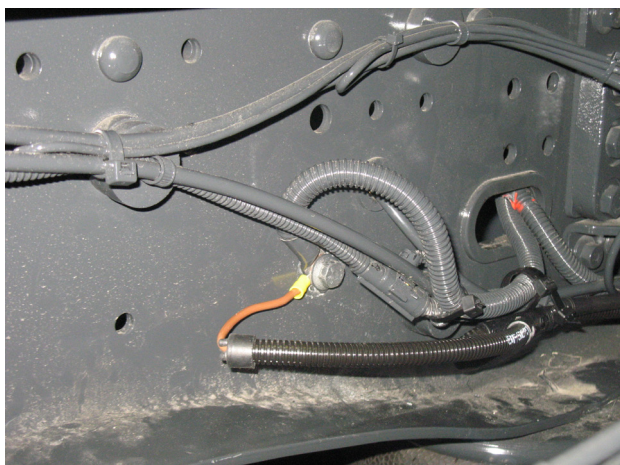
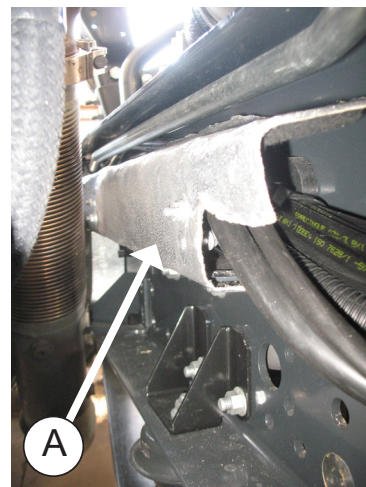

- 1 Doprowadź przewód zasilania urządzenia do wyłącznika prądu (*plus*) i do złącza masy (minus) pojazdu, mocując go za pomocą plastikowych jarzm (*do przyklejenia*) i kołnierzy w tylnej części kabiny; następnie przy odchylonej kabinie poprowadź przewód przez dolną część kabiny, mocując go za pomocą jarzm i śrub M4; aż do akumulatora z klamrami; W taki sam sposób zainstaluj przewód oryginalny (*prowadząc go przez środek osłony rury wydechowej (A)*). (*Żeby prawidłowo przykleić plastikowe podpory, starannie oczyść miejsce klejenia*). Po podłączeniu urządzenia do akumulatora zostanie przeprowadzony test diod LED, na wyświetlaczu pojawią się litery **88-bd**, następnie zgasną.



WAŻNE: Przed pierwszym uruchomieniem zapoznaj się z instrukcją obsługi.

Schemat elektryczny

WAŻNA UWAGA!

Należy uważać, aby nie zamienić biegunów przy podłączaniu zasilania do urządzenia. Wyświetlacz nie włącza się, a urządzenie wyłącza się.

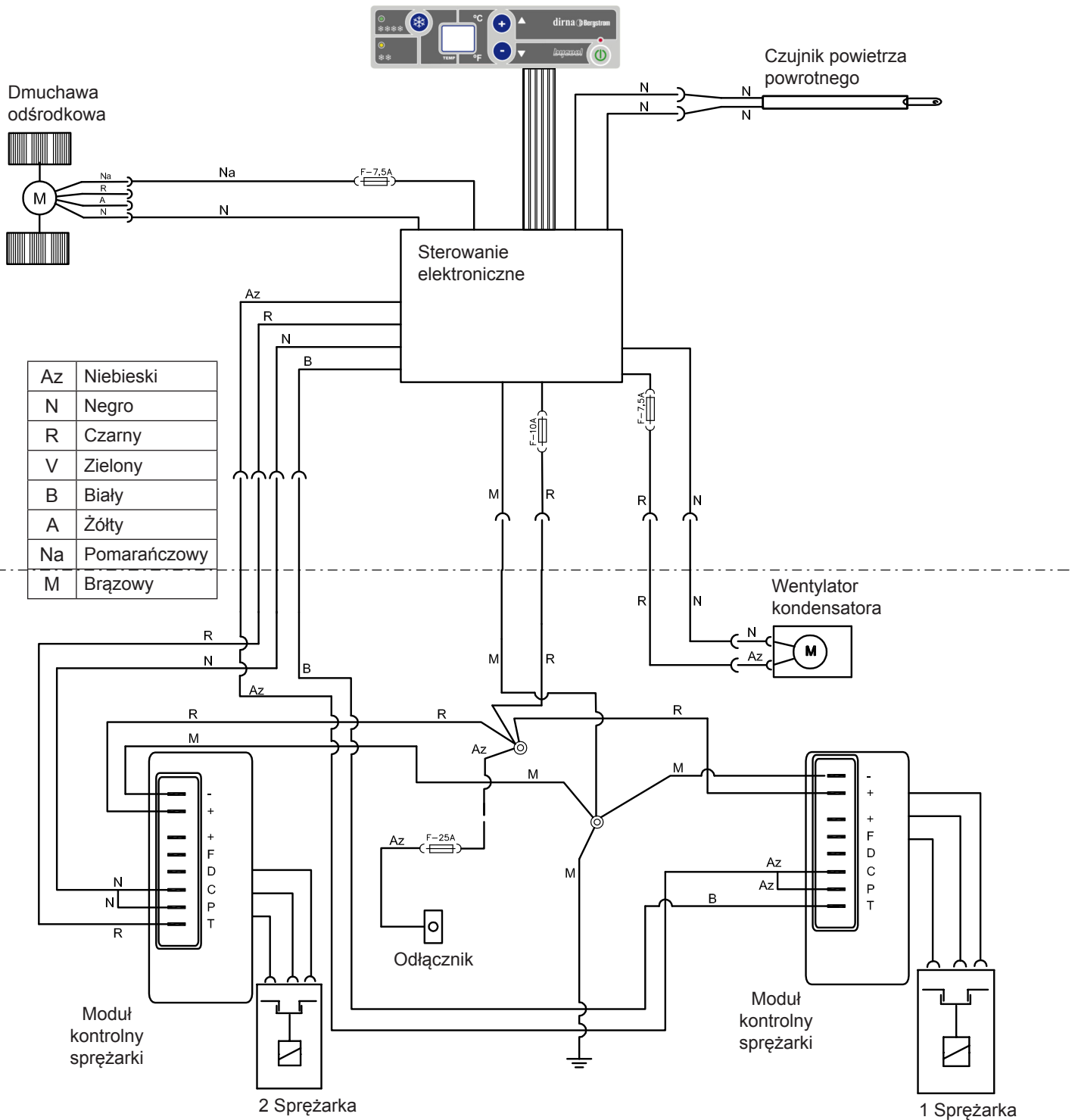

Blank page with horizontal dotted lines for writing.

Ed:	26/01/2016
Md:	05/11/2018

a



Francisco Alonso, 6
28806 Alcalá de Henares, Madrid
SPAIN

Contact	Phone	Fax	E-Mail
Sales (Ventas Internacional)	+34 91 8770510	+34 91 8771158	sales@dirna.bergstrominc.com
Comercial Nacional	+34 91 8775841	+34 91 8836321	ventas@dirna.bergstrominc.com
Orders & Deliveries (Logística internacional)	+34 91 8775846	+34 91 8771158	export@dirna.bergstrominc.com
Orders & Deliveries (Logística nacional)	+34 91 8775840	+34 91 8836321	comercial@dirna.bergstrominc.com
Technical Assistance (Internacional)	+49 511 86679681	+49 511 86679710	technicalassistance@dirna.bergstrominc.com
Technical Assistance (Nacional)	+34 91 8775845	+34 91 883 6321	oblanco@dirna.bergstrominc.com

www.dirna.com

	ATENCIÓN:	Dima Bergstrom se reserva el derecho de efectuar modificaciones en cualquier momento de los datos contenidos en esta publicación, por razones técnicas o comerciales.
	NOTE:	<i>For technical and commercial reasons, Dima Bergstrom reserves the right to change the data contained in this brochure.</i>
	ATTENTION:	Dima Bergstrom se réserve le droit d'effectuer à tout moment des modifications des données reprises sur cette publication, pour des raisons techniques ou commerciales.
	HIWEIS:	<i>Dima Bergstrom behält sich vor, aus technischen oder kaufmännischen Gründen jederzeit Änderungen der Angaben dieser Veröffentlichung vorzunehmen.</i>
	ATTENZIONE:	Dima Bergstrom si riserva il diritto di effettuare modifiche in qualsiasi momento ai dati contenuti in questa pubblicazione, per motivi tecnici o commerciali.